

# SATA 6Gb/s 2.5" SSD Manual

The SATA SSD is a non-volatile, solid-state storage device. With its Serial ATA interface and industry-standard form factors, it is a drop in replacement for hard disk drives. The SSD delivers extremely high levels of performance, reliability and ruggedness for I/O intensive or environmentally challenging applications.

Manual	12/6/18
PSFS2xxxxZxxx	Viking Technology
Revision G	Page 1 of 31

## Revision History

Date	Revision	Description	Checked By
2/7/17	A	Revise from modified PSFS22xxxGSxxx_D.	
3/13/17	B	Revise from modified PSFS22xxxGSxxx_D with new PN's, performance, block diagram, TBW power consumption and DEVSLP	
7/27/17	C	Add IOP values. Revise capacities to 64GB to 960GB	
8/14/17	D	Add IT PN's	
8/30/17	E	Remove EOL PN's VPFS22064GZCBMTL VPFS22120GZCBMTL VPFS22240GZCBMTL	
7/31/18	F	Add PN's VPFS22060GZixMTL	
12/5/18	G	Add PN's VPFS22480GZCHWT3 VPFS22512GZCHWT3 VPFS22960GZCHWT3 VPFS22001TZCHWT3	

Manual	12/6/18
PSFS2xxxxZxxx	Viking Technology
Revision G	Page 2 of 31

## Legal Information

### Legal Information

Copyright© 2018 Sanmina Corporation. All rights reserved. The information in this document is proprietary and confidential to Sanmina Corporation. No part of this document may be reproduced in any form or by any means or used to make any derivative work (such as translation, transformation, or adaptation) without written permission from Sanmina. Sanmina reserves the right to revise this documentation and to make changes in content from time to time without obligation on the part of Sanmina to provide notification of such revision or change.

Sanmina provides this documentation without warranty, term or condition of any kind, either expressed or implied, including, but not limited to, expressed and implied warranties of merchantability, fitness for a particular purpose, and non-infringement. While the information contained herein is believed to be accurate, such information is preliminary, and should not be relied upon for accuracy or completeness, and no representations or warranties of accuracy or completeness are made. In no event will Sanmina be liable for damages arising directly or indirectly from any use of or reliance upon the information contained in this document. Sanmina may make improvements or changes in the product(s) and/or the program(s) described in this documentation at any time.

Sanmina, Viking Technology, Viking Modular Solutions, and logo are trademarks of Sanmina Corporation. Other company, product or service names mentioned herein may be trademarks or service marks of their respective owners.

Manual	12/6/18
PSFS2xxxxZxxx	Viking Technology
Revision G	Page 3 of 31

## Ordering Information: 2.5" SSD Solid-State Drive

Part Number	Interface	User GB	Temp	NAND
VPFS22480GZCAMTL	SATA 6GB	480	(0 to +70'c)	TSB 15nm MLC
VPFS22960GZCZMTL	SATA 6GB	960	(0 to +70'c)	TSB 15nm MLC
VPFS22060GZIxMTL	SATA 6GB	60	(-40 to +85'c)	TSB 15nm MLC
VPFS22120GZIAMTL	SATA 6GB	120	(-40 to +85'c)	TSB 15nm MLC
VPFS22240GZIAMTL	SATA 6GB	240	(-40 to +85'c)	TSB 15nm MLC
VPFS22480GZIZMTL	SATA 6GB	480	(-40 to +85'c)	TSB 15nm MLC
VPFS22480GZCHWT3	SATA 6GB	480	(0 to +70'c)	TSB 3D MLC
VPFS22512GZCHWT3	SATA 6GB	512	(0 to +70'c)	TSB 3D MLC
VPFS22960GZCHWT3	SATA 6GB	960	(0 to +70'c)	TSB 3D MLC
VPFS22001TZCHWT3	SATA 6GB	1024	(0 to +70'c)	TSB 3D MLC

**Note:**

1. GB capacities based on power of 10, GiB capacities are based on powers of 2

Manual	12/6/18
PSFS2xxxxZxxx	Viking Technology
Revision G	Page 4 of 31

## Product Picture(s)



Manual	12/6/18
PSFS2xxxxZxxx	Viking Technology
Revision G	Page 5 of 31

## Table of Contents

<b>1</b>	<b>INTRODUCTION</b>	<b>9</b>
1.1	Features	9
1.2	Block Diagram	10
1.3	SATA Interface	11
<b>2</b>	<b>PRODUCT SPECIFICATIONS</b>	<b>12</b>
2.1	Capacity and LBA count	12
2.2	Performance	12
2.3	Timing	13
2.3.1	STANDBY IMMEDIATE Command	13
2.4	Electrical Characteristics	14
2.4.1	Absolute Maximum Ratings	14
2.4.2	Supply Voltage	14
2.4.3	Power Consumption	15
2.5	Environmental Conditions	15
2.5.1	Temperature and Altitude	15
2.5.2	Shock and Vibration	16
2.5.3	Electromagnetic Immunity	16
2.6	Reliability	16
<b>3</b>	<b>MECHANICAL INFORMATION</b>	<b>17</b>
3.1	SSD Physical Dimensions	17
3.2	SSD Weight	18
<b>4</b>	<b>PIN AND SIGNAL DESCRIPTIONS</b>	<b>18</b>
4.1	SSD Signal and Power Description Tables	18
4.2	Hot Plug Support	18
<b>5</b>	<b>COMMAND SETS</b>	<b>19</b>

Manual	12/6/18
PSFS2xxxxZxxx	Viking Technology
Revision G	Page 6 of 31

<b>5.1</b>	<b>ATA Commands</b>	<b>19</b>
5.1.1	48-Bit Address Command Set	20
5.1.2	ATA General Feature Command Set	20
5.1.3	Device Configuration Overlay Command Set	20
5.1.4	General Purpose Log Command Set	21
5.1.5	Host Protected Area Command Set	21
5.1.6	Power Management Command Set	21
5.1.7	Security Mode Feature Set	21
5.1.8	Identify Device Data	22
5.1.1	S.M.A.R.T. Support	25
5.1.2	SATA 3.0 S.M.A.R.T. Command Set	26
<b>5.2</b>	<b>SATA Commands</b>	<b>30</b>
5.2.1	Native Command Queuing (NCQ)	30
<b>6</b>	<b>REFERENCES</b>	<b>30</b>
<b>7</b>	<b>GLOSSARY</b>	<b>31</b>

Manual	12/6/18
PSFS2xxxxZxxx	Viking Technology
Revision G	Page 7 of 31

## Table of Tables

Table 2-1: Maximum Sustained Read and Write Bandwidth _____	12
Table 2-2: Random Read and Write Input/Output Operations per Second (IOPS) _____	13
Table 2-3: Timing Specifications _____	13
Table 2-4: STANDBY IMMEDIATE Timing _____	13
Table 2-5: Absolute Maximum Ratings _____	14
Table 2-6: Operating Voltage _____	14
Table 2-7: Typical Power Consumption _____	15
Table 2-8: Temperature and Altitude Related Specifications _____	15
Table 2-9: Shock and Vibration Specifications _____	16
Table 2-10: Reliability Specifications _____	16
Table 2-11: Write Endurance Specifications _____	16
Table 3-1: Physical Dimensions _____	17
Table 4-1: Serial ATA Connector Pin Signal Definitions _____	18
Table 4-2: Serial ATA Power Pin Definitions _____	18
Table 5-1: Supported ATA Commands _____	19
Table 5-2: List of Device Identification _____	22
Table 5-3: S.M.A.R.T. Command Set _____	26
Table 5-4: Extended SMART Attribute Table _____	26
Table 5-5: Extended SMART Attribute Actual Data _____	27
Table 5-6: Supported S.M.A.R.T. EXECUTE OFF-LINE IMMEDIATE Subcommands _____	29

## Table of Figures

Figure 1-1: High-Level Block Diagram _____	10
Figure 3-1: 2.5" SSD Case Dimensions _____	17



## 1 Introduction

Viking SSD's offer the highest flash storage reliability and performance as well as support for many functional features.

### 1.1 Features

The SSD delivers the following features:

- Offers seamless SATA Revision 3.0 interface support for SATA up to 6Gb/s
- Low overall SSD power consumption
- Supports Native Command Queuing (NCQ) to 32 commands
- Compatible with all major SLC and MLC flash technologies
- S.M.A.R.T.
- Superior wear-leveling algorithm
- Efficient error recovery
- TRIM

Manual	12/6/18
PSFS2xxxxZxxx	Viking Technology
Revision G	Page 9 of 31

## 1.2 Block Diagram

Figure 1-1: High-Level Block Diagram

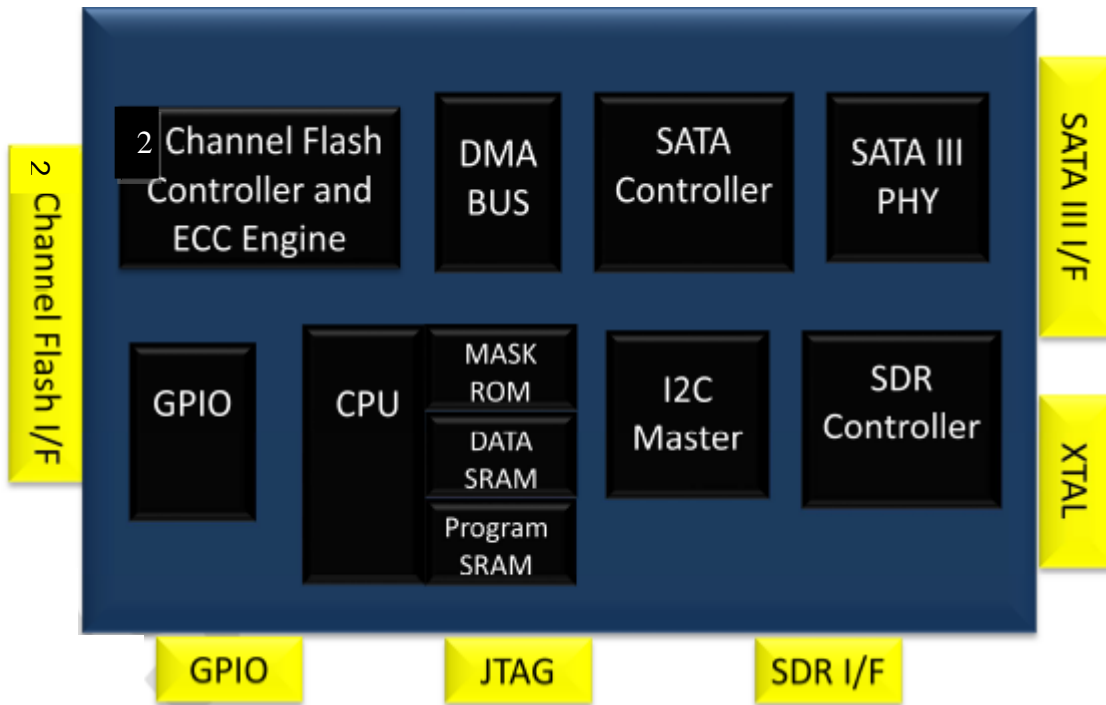

**Notes:** Support for up to 2-channels and 2 CE in the NAND Flash interface

Manual	12/6/18
PSFS2xxxxZxxx	Viking Technology
Revision G	Page 10 of 31

### 1.3 SATA Interface

- The Serial ATA (SATA) interface is compliant with the SATA IO Serial ATA specification, revision 3.0 that supports SATA up to 6Gb/s.
- The SATA interface connects the host computer to the SSD subsystem.
- The SATA interface runs at a maximum speed of 6 Gbps (Giga-bits per second). If the host computer is unable to negotiate a speed of 6 Gbps, the SATA interface automatically renegotiates to a speed of 3 Gbps or 1.5 Gbps.

For a list of supported commands and other specifics, please see Chapter 5.

Manual	12/6/18
PSFS2xxxxZxxx	Viking Technology
Revision G	Page 11 of 31

## 2 Product Specifications

### 2.1 Capacity and LBA count

Raw Capacity (GB)	User Capacity (GB)	LBA Count
64	60	117,231,408
64	64	125,045,424
128	120	234,441,648
128	128	250,069,680
256	240	468,862,128
256	256	500,118,192
512	480	937,703,088
512	512	1,000,215,216
1024	960	1,875,385,008
1024	1024	2,000,409,264

**Notes:**

- Per [www.idema.org](http://www.idema.org), LBA1-03 spec,  
LBA counts = (97,696,368) + (1,953,504 \* (Advertised Capacity in GBytes – 50))
- GB capacities based on power of 10, GiB capacities are based on powers of 2

### 2.2 Performance

**Table 2-1: Maximum Sustained Read and Write Bandwidth**

Capacity	Flash Structure	Performance			
		CrystalDiskMark		ATTO	
		Read (MB/s)	Write (MB/s)	Read (MB/s)	Write (MB/s)
8GB	8GBx1, TSOP, TSB	320	100	320	100
16GB	16GBx1, TSOP, TSB	320	100	320	100
30/32GB	16GBx2, TSOP, TSB	550	175	560	540
60/64GB	16GBx4, TSOP, TSB	550	335	560	540
120/128GB	32GBx4, TSOP, TSB	550	465	560	540
240/256GB	64GBx4, TSOP, TSB	550	465	560	540
480/512GB	128GBx4, TSOP, TSB	550	465	560	540
960/1024GB	128GBx4, TSOP, TSB	550	465	560	540

**Notes:**

- Performance measured using CrystalDiskMark and ATTO
- Performance may vary from flash configuration, SDR configuration, and platform.
- Refer to Application Note AN0006 for Viking SSD Benchmarking Methodology.
- Data is based on SSD's using Toshiba A15nm Toggle NAND devices

**Table 2-2: Random Read and Write Input/Output Operations per Second (IOPS)**

Access Type	IOPS
Read, 4K	Up to 95,000
Write, 4K	Up to 85,000

**Notes:**

3. Performance measured using Iometer 08 with queue depth set to 32.
4. Write Cache enabled with DDR cache.
5. Random IOPS cover the entire range of legal logical block addresses (LBA's). Measurements are performed on a full drive (all LBA's have valid content).
6. Performance may vary by NAND type and host.
7. Refer to Application Note AN0006 for Viking SSD Benchmarking Methodology.
8. Data is based on SSD's using Toshiba A19nm NAND devices

## 2.3 Timing

**Table 2-3: Timing Specifications**

Type	Average Latency
Power-On-to-Ready (POR)	TBD
Command to DRQ	TBD
Time to Erase (ATA Secure Erase)	TBD

**Notes:**

1. Device measured using Drivemaster.
2. Sector Read/Write latency measured up to 2048 block transfers (512B/sector = 1 Block)
3. Queue depth set to 32 for NCQ
4. Sequential IOPS cover the entire range of legal logical block addresses (LBA's). Measurements are performed on a full drive (all LBA's have valid content)
5. DRQ (Data Transfer Requested) bit being asserted

### 2.3.1 STANDBY IMMEDIATE Command

The Power-On-to-Ready time assumes a proper shutdown (power removal preceded by STANDBY IMMEDIATE command. A STANDBY IMMEDIATE before power down always performs a graceful shutdown and does not require the use of the hold-up circuit. Note that SMART attribute 174 "Unexpected Power Loss" records the number of non-graceful power cycle events.

**Table 2-4: STANDBY IMMEDIATE Timing**

Power Cycle Endurance	Min	Max	Unit
STANDBY IMMEDIATE to WE completed	-	72.9	ms

**Notes:** From Standby Immediate command to NAND Write Protect enable.

## 2.4 Electrical Characteristics

### 2.4.1 Absolute Maximum Ratings

Values shown are stress ratings only. Functional operation outside normal operating values is not implied. Extended exposure to absolute maximum ratings may affect reliability.

**Table 2-5: Absolute Maximum Ratings**

Description	Min	Max	Unit
Maximum Voltage Range for $V_{in}$	-0.2	6	V
Maximum Temperature Range	-40	85	c

### 2.4.2 Supply Voltage

The operating voltage is 5.0v

Table 2-6: Operating Voltage

Description	Min	Max	Unit
Operating Voltage for 5.0 V (+/- 5%)	4.75	5.25	V

### 2.4.3 Power Consumption

All onboard power requirements of the SSD are derived from the SATA 5.0V input rail.

**Table 2-7: Typical Power Consumption**

Capacity	Flash Structure	Power Consumption		
		Read (mW)	Write (mW)	DEVSLP (mW)
8GB	8GBx1, TSOP, TSB	1,080	1,300	4.9
16GB	16GBx1, TSOP, TSB	1,085	1,350	4.9
30/32GB	16GBx2, TSOP, TSB	1,090	1,350	4.9
60/64GB	16GBx4, TSOP, TSB	1,095	1,360	4.9
120/128GB	32GBx4, TSOP, TSB	1,000	1,600	4.9
240/256GB	64GBx4, TSOP, TSB	1,015	1,605	4.9
480/512GB	128GBx4, TSOP, TSB	1,565	1,910	4.9
960/1024GB	256GBx4, TSOP, TSB	1800	2100	4.9

**NOTES:**

1. The average value of power consumption is achieved based on 100% conversion efficiency.
2. The measured power voltage is 5V.
3. Samples were built using Toshiba MLC  
It's measured under ambient temperature.
4. DEVSLP is measured while entering device sleep mode for 5 minutes.
5. Estimated. Power Consumption may differ according to flash configuration and platform.

## 2.5 Environmental Conditions

### 2.5.1 Temperature and Altitude

**Table 2-8: Temperature and Altitude Related Specifications**

Conditions	Operating	Shipping	Storage
Commercial Temperature- Ambient	0 to 70°C	-40 to 85°C	-40 to 85°C
Industrial Temperature- Ambient	-40 to 85°C	-40 to 85°C	-40 to 85°C
Humidity (non-condensing)	90% under 40C	93% under 40C	93% under 40C

**Notes:**

1. SLC flash based products may be available in the following temperature ranges:

### 2.5.2 Shock and Vibration

SSD products are tested in accordance with environmental specification for shock and vibration

**Table 2-9: Shock and Vibration Specifications**

Stimulus	Description		
Shock	500G (2ms)		
Vibration	Condition		Vibration Orientation
	Frequency/Displacement	Frequency/Acceleration	
Non-operational	20Hz~80Hz/1.52mm	80Hz~2000Hz/20G	X, Y, Z axis/30 min for each

### 2.5.3 Electromagnetic Immunity

This SSD is an embedded product for host systems and is designed not to impair with system functionality or hinder system EMI/FCC compliance.

## 2.6 Reliability

**Table 2-10: Reliability Specifications**

Parameter	Value
ECC	72-bit per 1KByte
MTBF	~ 2,000,000 hours
Read Endurance	Unlimited
Data retention	> 90 days at NAND expiration

**Table 2-11: Write Endurance Specifications**

Capacity	Flash Structure	TBW
8GB	8GB x 1	15
16GB	16GB x 1	26
30/32GB	16GB x 2	48
60/64GB	16GB x 4	90
120/128GB	32GB x 4, 64GB x 2	181
240/256GB	64GB x 4	262
480/512GB	128GB x 4	544
960/1024GB	256GB x 4	1088

**Notes:**

1. Samples were built using Toshiba MLC and
2. The test followed JEDEC219A client endurance workload.
3. TBW may differ according to flash configuration and platform.



4. The endurance of SSD could be estimated based on user behavior, NAND endurance cycles, and write amplification factor. It is not guaranteed by flash vendor.

### 3 Mechanical Information

#### 3.1 SSD Physical Dimensions

Table 3-1: Physical Dimensions

	Dimensions	Units
Height / Thickness	7.00	mm
Width	69.85	mm
Length	100.5 Max	mm

Figure 3-1: 2.5" SSD Case Dimensions

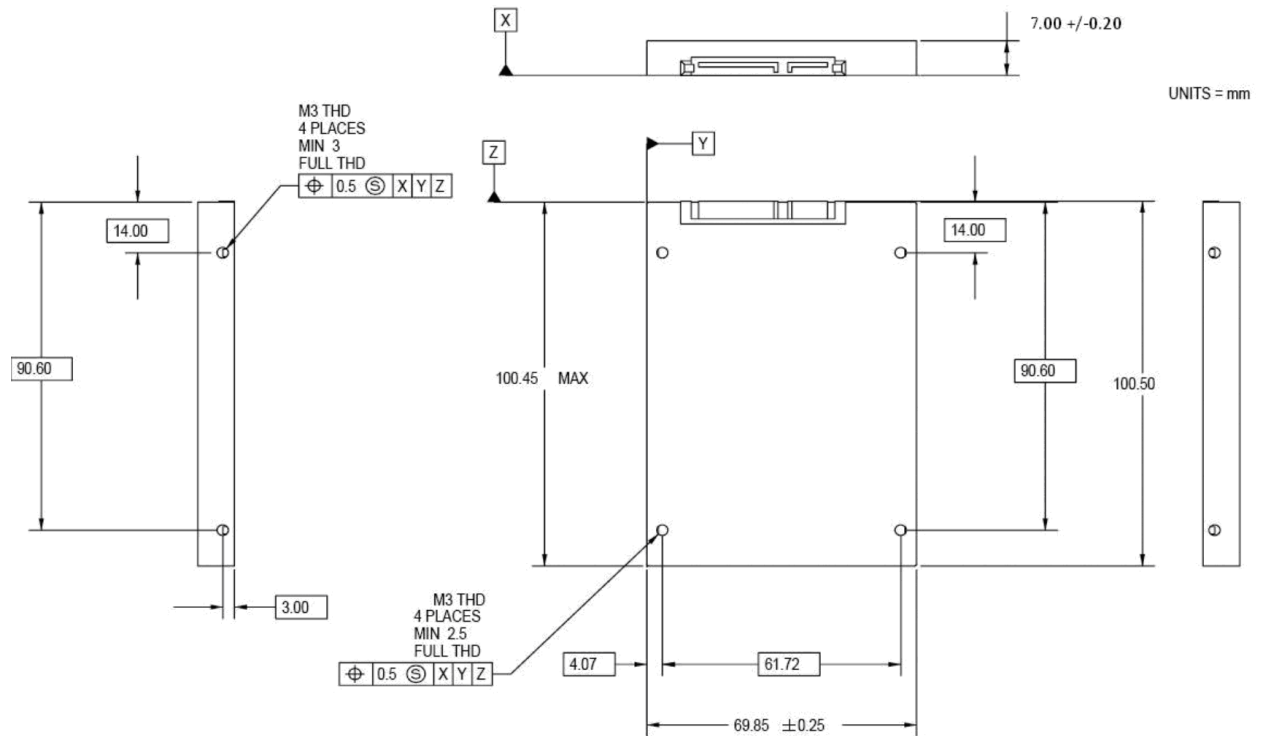

**Notes:** All dimensions are in millimeters, +/- 0.2mm, unless otherwise stated. Reference SATA connector specifications

Manual	12/6/18
PSFS2xxxxZxxx	Viking Technology
Revision G	Page 17 of 31

### 3.2 SSD Weight

The weight of the 2.5" SSD is approximately 100 grams.

## 4 Pin and Signal Descriptions

### 4.1 SSD Signal and Power Description Tables

**Table 4-1: Serial ATA Connector Pin Signal Definitions**

Pin	Function	Definition	Mating Order
S1	SGND_1	Signal Ground	2nd
S2	RX+ on SSD, TX+ on Host	Differential Signal	1st
S3	RX- on SSD, TX- on Host	Differential Signal	1st
S4	SGND_2	Signal Ground	2nd
S5	TX- on SSD, RX- on Host	Differential Signal	1st
S6	TX+ on SSD, RX+ on Host	Differential Signal	1st
S7	SGND_3	Signal Ground	2nd

**Notes:** Key and spacing separate signal and power segments. Pin locations and layout are consistent with SATA specification.

**Table 4-2: Serial ATA Power Pin Definitions**

Pin	Function	Definition	Mating Order
P1	3.3V_1	No connection (open circuit)	2nd
P2	3.3V_2	No connection (open circuit)	2nd
P3	DEVSLP	Enter/Exit Device sleep mode	1st
P4	GND_1	Ground	1st
P5	GND_2	Ground	1st
P6	GND_3	Ground	1st
P7	5V_1	5VDC Power precharge	1st
P8	5V_2	5VDC Power	2nd
P9	5V_3	5VDC Power	2nd
P10	GND_4	Ground	1st
P11	Activity	No connection (open circuit)	2nd
P12	GND_5	Ground	1st
P13	12V_1	No connection (open circuit)	
P14	12V_2	Optional 10k-ohm PD for legacy support on old versions.	
P15	12V_3		

### 4.2 Hot Plug Support

Hot Plug insertion and removal are supported in the presence of a proper connector and appropriate operating system (OS) support as described in the SATA 2.6 specification. This product supports Asynchronous Signal Recovery

and will issue an unsolicited COMINIT when first mated with a powered connector to guarantee reliable detection by a host system without hardware device detection.

## 5 Command Sets

### 5.1 ATA Commands

**Table 5-1: Supported ATA Commands**

Description	Op Code	Description	Op Code
Check power mode	E5h	Security Disable Password	F6h
Data Set management	06h	Security Erase Prepare	F3h
DCO	B1h	Security Erase Unit	F4h
Download Microcode PIO	92h	Security Freeze Lock	F5h
Download Microcode DMA	93h	Security Set Password	F1h
Execute drive diagnostic	90h	Security Unlock	F2h
Flush cache	E7h	Seek	70h
Flush cache Ext	EAh	Set features	EFh
Identify device	ECh	Set Max Address	F9h
Idle	E3h	Set Max Address Ext	37h
Idle immediate	E1h	Set multiple mode	C6h
Initialize drive parameters	91h	Sleep	E6h
Read buffer	E4h	Smart	B0h
Read DMA (w/o retry)	C9h	Standby	E2h
Read DMA (w/retry)	C8h	Standby immediate	E0h
Read DMA Ext	25h	Write buffer	E8h
Read FPDMA QUEUED	60h	Write DMA (w/o retry)	CBh
Read Log Ext	2Fh	Write DMA (w/retry)	CAh
Read multiple	C4h	Write DMA Ext	35h
Read multiple Ext	29h	Write DMA FUA Ext	3Dh
Read native max address	F8h	Write FPDMA QUEUED	61h
Read native max Ext	27h	Write Log Ext	3Fh
Read sector(s) (w/o retry)	21h	Write multiple	C5h
Read sector(s) (w/retry)	20h	Write multiple Ext	39h
Read sector(s) Ext	24h	Write multiple FUA Ext	CEh
Read Verify Ext	42h	Write sector(s) (w/o retry)	31h
Read verify sector(s) (w/o retry)	41h	Write sector(s) (w/retry)	30h

Description	Op Code	Description	Op Code
Read verify sector(s) (w/retry)	40h	Write sector(s) Ext	34h
Recalibrate	10h	Write uncorrectable	45h

### 5.1.1 48-Bit Address Command Set

SSD supports the 48-Bit Address command set consisting of:

- Flush Cache Ext
- Read DMA Ext
- Read native Max Address Ext
- Read Sector(s) Ext
- Set Max Address Ext
- Write DMA Ext
- Write Multiple Ext
- Write Sector(s) Ext

### 5.1.2 ATA General Feature Command Set

SSD supports the ATA General Feature command set consisting of:

- Download Microcode
- Executive Device Diagnostics
- Flush Cache
- Identify Device
- NOP (optional)
- Read Buffer (optional)
- Read DMA
- Read Multiple
- Read Sector(s)
- Read Verify Sector(s)
- Seek
- Set Features
- Set Multiple Mode
- Write Buffer (optional)
- Write DMA
- Write Multiple
- Write Sector(s)

### 5.1.3 Device Configuration Overlay Command Set

SSD supports the Device Configuration Overlay command set consisting of:

Manual	12/6/18
PSFS2xxxxZxxx	Viking Technology
Revision G	Page 20 of 31

- Device Configuration Freeze Lock
- Device Configuration Identity
- Device Configuration Restore
- Device Configuration Set

#### **5.1.4 General Purpose Log Command Set**

SSD supports the General Purpose Log command set consisting of:

- Read Log Ext
- Write Log Ext

#### **5.1.5 Host Protected Area Command Set**

SSD supports the Host Protected Area command set consisting of:

- Read Native Max Address
- Read Native Max Address Ext
- Set Max Address
- Set Max Address Ext
- Set Max Freeze Lock (optional)
- Set Max Lock (optional)
- Set Max Set Password (optional)
- Set Max Unlock (optional)

#### **5.1.6 Power Management Command Set**

SSD supports the Power Management command set consisting of:

- Check Power Mode
- Idle
- Idle Immediate
- Sleep
- Standby
- Standby Immediate
- Slumber
- Partial Mode

#### **5.1.7 Security Mode Feature Set**

SSD supports the Security Mode command set consisting of:

- Security Set Password (OPCODE: F1h)
- Security Unlock (OPCODE: F2h)
- Security Erase Prepare (OPCODE: F3h)
- Security Erase Unit (OPCODE: F4h)
- Security Freeze Lock (OPCODE: F5h)
- Security Disable Password (OPCODE: F6h)
- Standby Immediate

Manual	12/6/18
PSFS2xxxxZxxx	Viking Technology
Revision G	Page 21 of 31

### 5.1.8 Identify Device Data

The table below lists the sector data that will be returned by the SSD upon an IDENTIFY DEVICE command.

**Table 5-2: List of Device Identification**

Word	F: Fixed V: Variable X: Both	Default Value	Description
0	F	0040h	General configuration bit-significant information
1	X	See *1	Obsolete – Number of logical cylinders (16383)
2	V	C837h	Specific configuration
3	X	0010h	Obsolete – Number of logical heads (16)
4-5	X	00000000h	Retired
6	X	003Fh	Obsolete – Number of logical sectors per logical track (63)
7-8	V	00000000h	Reserved for assignment by the Compact Flash Association
9	X	0000h	Retired
10-19	F	Varies	Serial number (20 ASCII characters)
20-21	X	0000h	Retired
22	X	0000h	Obsolete
23-26	F	Varies	Firmware revision (8 ASCII characters)
27-46	F	Varies	Model number (xxxxxxx)
47	F	8010h	7:0- Maximum number of sectors transferred per interrupt on MULTIPLE commands
48	F	0000h	Reserved
49	F	2F00h	Capabilities
50	F	4000h	Capabilities
51-52	X	00000000h	Obsolete
53	F	0007h	Words 88 and 70:64 valid
54	X	See *1	Obsolete – Number of logical cylinders (16383)
55	X	0010h	Obsolete – Number of logical heads (16)
56	X	003Fh	Obsolete – Number of logical sectors per track (63)
57-58	X	See *2	Obsolete – Current capacity in sectors –
59	F	0110h	Number of sectors transferred per interrupt on MULTIPLE commands
60-61	F	See *3	Total number of user addressable sectors
62	X	0000h	Obsolete
63	F	0407h	Multi-word DMA modes supported/selected
64	F	0003h	PIO modes supported
65	F	0078h	Minimum Multiword DMA transfer cycle time per word
66	F	0078h	Manufacturer’s recommended Multiword DMA

Word	F: Fixed V: Variable X: Both	Default Value	Description
			transfer cycle time
67	F	0078h	Minimum PIO transfer cycle time without flow control
68	F	0078h	Minimum PIO transfer cycle time with IORDY flow control
69	F	0100h	Additional Supported (support download microcode DMA)
70	F	0000h	Reserved
71-74	F	0000000000000000 0h	Reserved for the IDENTIFY PACKET DEVICE command
75	F	001Fh	Queue depth
76	F	670eh	Serial SATA capabilities
77	F	0084h	Reserved for future Serial ATA definition
78	F	0014h	Serial ATA features supported
79	V	0040H	Serial ATA features enabled
80	F	01F8h	Major Version Number
81	F	0000h	Minor Version Number
82	F	346Bh	Command set supported
83	F	7D09h	Command set supported
84	F	6063h	Command set/feature supported extension
85	V	3469h	Command set/feature enabled
86	V	BC01h	Command set/feature enabled
87	V	6063h	Command set/feature default
88	V	003Fh	Ultra DMA Modes
89	F	001Eh	Time required for security erase unit completion
90	F	001Eh	Time required for Enhanced security erase completion
91	V	0000h	Current advanced power management value
92	V	FFFEh	Master Password Revision Code
93	F	0000h	Hardware reset result. The contents of the bits (12:0) of this word shall change only during the execution of s hardware reset.
94	V	0000h	Vendor's recommended and actual acoustic management value
95	F	0000h	Stream Minimum Request Size
96	V	0000h	Streaming Transfer Time – DMA
97	V	0000h	Streaming Access Latency – DMA and PIO
98-99	F	0000h	Streaming Performance Granularity
100-103	V	See *4	Maximum user LBA for 48 bit Address feature set
104	V	0000h	Streaming Transfer Time – PIO
105	F	0000h	Maximum number of 512-byte blocks per DATA SET MANAGEMENT command
106	F	4000h	Physical sector size / Logical sector size

Word	F: Fixed V: Variable X: Both	Default Value	Description
107	F	0000h	Inter-seek delay for ISO-7779 acoustic testing in microseconds
108-111	F	0000000000000000 0h	Unique ID
112-115	F	0000000000000000 0h	Reserved
116	V	0000h	Reserved
117-118	F	00000000h	Words per logical Sector
119	F	4014h	Supported settings
120	F	4014h	Command set/Feature Enabled/Supported
121-126	F	0h	Reserved
127	F	0h	Removable Media Status Notification feature set support
128	V	0021h	Security status
129-159	X	0h	Vendor specific
160	F	0h	Compact Flash Association (CFA) power mode 1
161-167	X	0h	Reserved for assignment by the CFA
168	F	3h: 2.5 inch 4h: 1.8 inch 5h: < 1.8 inch	Device Nominal Form Factor
169	F	0001h	DATA SET MANAGEMENT command is supported
170-173	F	0h	Additional Product Identifier
174-175		0h	Reserve
176-205	V	0h	Current media serial number
206	F	0h	SCT Command Transport(
207-208	F	0h	Reserved
209	F	4000h	Alignment of logical blocks within a physical block
210-211	V	0000h	Write-Read-Verify Sector Count Mode 3 (not supported)
212-213	F	0000h	Write-Read-Verify Sector Count Mode 2 (not supported)
214-216		0000h	NV Cache relate (not supported)
217	F	0001h	Non-rotating media device
218	F	0h	Reserved
219	F	0h	NV Cache relate (not supported)
220	V	0h	Write read verify feature set current mode
221		0h	Reserved
222	F	107Fh	Transport major version number
223	F	0h	Transport minor version number
224-229		0h	reserved
230-233		0h	Extend number of user addressable sectors
234		0001h	Minimum number of 512-byte data blocks per



Word	F: Fixed V: Variable X: Both	Default Value	Description
			DOWNLOAD MICROCODE command for mode 03h
235		0080h	Maximum number of 512-byte data blocks per DOWNLOAD MICROCODE command for mode 03h
236-254	F	0h	Reserved
255	X	XXA5h XX is variable	Integrity word (Checksum and Signature)

### Notes for Capacity specific Device Identification

Capacity (GB)	*1	*2	*3	*4
	(Word 1/Word 54)	(Word 57-58)	(Word 60-61)	(Word 100-103)
4	1E5Dh	778E30h	778E30h	778E30h
8	3CA5h	EEC9B0h	EEC9B0h	EEC9B0h
16	3FFFh	FBFC10h	1DD40B0h	1DD40B0h
24	3FFFh	FBFC10h	2CBB7B0h	2CBB7B0h
32	3FFFh	FBFC10h	3BA2EB0h	3BA2EB0h
64	3FFFh	FBFC10h	774OAB0h	774OAB0h
128	3FFFh	FBFC10h	EE7C2B0h	EE7C2B0h
256	3FFFh	FBFC10h	FFFFFFFFh	1DCF32B0h

#### 5.1.1 S.M.A.R.T. Support

Data storage drives capture a variety of information during operation that may be used to analyze drive —health. SATA drives provide Self-Monitoring, Analysis and Reporting Technology (SMART) features that include monitoring and storing critical performance and calibration parameters to attempt to predict the likelihood of near-term degradation or fault conditions. Drive manufacturers have adopted S.M.A.R.T. to help warn system software, a system administrator, or a user of impending drive failure, while time remains to take preventive action. It provides the host system with the knowledge of a negative reliability condition to allow the host system to warn the user of the impending risk of data loss and advise the user of the appropriate action.

The technical documentation for S.M.A.R.T. is captured in the AT Attachment (ATA) standard. The standard defines the protocols for reporting errors and for invoking self-tests to collect and analyze data on demand. The ATA specification is flexible and provides for individual manufacturers to define their own unique vendor specific information. This section describes the baseline supported

Manual	12/6/18
PSFS2xxxxZxxx	Viking Technology
Revision G	Page 25 of 31

S.M.A.R.T. command attributes. The information herein should be used in conjunction with the ATA standard and related documents, which may serve as references for topics and details not addressed here. Further, it is recommended to consult the list of public S.M.A.R.T. attributes.

See the AT Attachment standard for implementation details.

### 5.1.2 SATA 3.0 S.M.A.R.T. Command Set

The supported S.M.A.R.T. command set is listed in the table below. See the AT Attachment standard for implementation details.

**Table 5-3: S.M.A.R.T. Command Set**

Value (hex)	Command
00-CF	Reserved
D0	S.M.A.R.T. read attributes
D1*	S.M.A.R.T. read threshold
D2	S.M.A.R.T. enable/disable attribute autosave
D3*	S.M.A.R.T. save attribute values
D4	S.M.A.R.T. execute off-line immediate
D5	S.M.A.R.T. read log sector
D6	S.M.A.R.T. write log sector
D7*	S.M.A.R.T. write attribute threshold
D8	S.M.A.R.T. enable operations
D9	S.M.A.R.T. disable operations
DA	S.M.A.R.T. return status
DB	S.M.A.R.T. enable/disable automatic off-line
DC-FF	Reserved (Vendor Specific)
* Note that D1, D3, and D7 have been made obsolete in the ATA-8 specification.	

#### 5.1.2.1 Extended SMART Attributes

**Table 5-4: Extended SMART Attribute Table**

SMART Attribute ID	Description
01h	Number of accumulated Uncorrectable errors (Range 0-255) Read Error Rate
05h	Reallocated Sector Count
09h	Power-On hours Count (Range 0-4294967295)

SMART Attribute ID	Description
0Ch	Drive Power Cycle Count (Number of accumulated power on/off cycles)
A8h	SATA PHY Error Count (only record from power on, when power off this value will clear to zero) this value include all PHY error count, ex data FIS CRC ,code error, disparity error ,command FIS CRC .....
AAh	Max Bad Block Count (will show early bad and later bad block count)
ADh	Erase count (average, max, erase count)
B1h	Wear Range delta [(most wear block – average wear block)/Max P/E cycles] x 100
B5h	Program Fail Count
B6h	Erase Failure Block Count
BBh	Reported Uncorrectable Errors (ECC fail count) 4bytes 01h only 1 bytes
C0h	Unexpected Power Loss Count
C2h	N/A
C7h	Number of accumulated CRC Error (read/write data FIS CRC error) CRC Error Count (R CRC + W CRC)
DAh	Number of accumulated CRC Error (read/write data FIS CRC error) Number of CRC Errors
E7h	SSD life remaining
E8h	Read Failure Block Count
E9h	Lifetime Writes to Flash ((GB)
F1h	Lifetime Writes from Host (each G)
F2h	Lifetime Reads from Host (each G)
F3h	Total internal copy ecc error count
F4h	Average erase count (4bytes)
F5h	Max erase count (4 bytes)
F6h	Total Erase Count (6 bytes)
FAh	Read retry count
FBh	Do wearleveling count
FCh	CRC error write count

**Notes:** Dummy is null and not used

**Table 5-5: Extended SMART Attribute Actual Data**

0	1	2	3	4	5	6	7	8	9	10	11	
---	---	---	---	---	---	---	---	---	---	----	----	--

Manual	12/6/18
PSFS2xxxxZxxx	Viking Technology
Revision G	Page 27 of 31

ID	Flag	Flag	Value	Worse	DATA							Threshold
01h	0Bh	00h	64h	64h	0	0	ECC error	0	0	0	0	32h
05h	13h	00h	64h	64h	0	0	0	0	0	0	0	32h
09h	12h	00h	64h	64h	Power on hour		0	0	0	0	0	00h
0Ch	12h	00h	64h	64h	Power on/off cycles				0	0	0	00h
A8h	12h	00h	64h	64h	SATA PHY error count				0	0	0	00h
AAh	03h	00h	<b>Note 1</b>	<b>Note 1</b>	Early bad block NO		0	0	Later bad block NO		0	0Ah
ADh	12h	00h	64h	64h	Max erase count (MAX 65535)		Average erase count (MAX 65535)		0 0		0	00h
B1h	00h	00h	00h	00h	The value				0	0	0	00h
B5h	12h	00h	00h	00h	Total program bad blocks count				0	0	0	00h
B6h	32h	00h	00h	00h	Total erase bad blocks count				0	0	0	00h
BBh	03h	00h	00h	00h	Total ECC error count				0	0	0	00h
C0h	12h	00h	64h	64h	number of accidental power loss count				0	0	0	00h
C2h	N/A	N/A	N/A	N/A	N/A		N/A		N/A		N/A	N/A
C7h	12h	00h	64h	64h	CRC Error Count (R CRC + W CRC)				0	0	0	00h
DAh	0Bh	00h	64h	64h	Number of CRC Error				0	0	0	32h
E7h	13h	00h	64h	64h	% SSD life remaining (Note 2)				0	0	0	00h
E8h	0Bh	00h	64h	64h	Total Read bad Block Count				0	0	0	00h
E9h	0Bh	00h	64h	64h	Flash write 64GB each count				0	0	0	00h
F1h	32h	00h	00h	00h	Host write 64GB count				0	0	0	00h
F2h	32h	00h	00h	00h	Host read 64GB count)				0	0	0	00h
F3h	02h	00h	64h	64h	Total internal copy ecc error count				0	0	0	00h
F4h	02h	00h	64h	64h	Total Average erase count				0	0	0	00h
F5h	02h	00h	64h	64h	Max erase count				0	0	0	00h
F6h	02h	00h	64h	64h	Total Erase Count						0	00h

0	1	2	3	4	5	6	7	8	9	10	11		
ID	Flag	Flag	Value	Worse	DATA							Threshold	
FAh	02h	00h	64h	64h	Read retry Count							0	00h
FBh	02h	00h	64h	64h	Cool down Count							0	00h
FCh	02h	00h	64h	64h	CRC write Count							0	00h

**Note 1 Formula:**

MABN: Maximum acceptable bad block number

CBBN: Current bad block number

Value = ((MABN – CBBN)/ (MABN )) x 100

This formula calculates percentage of spare blocks. Value will be from 100 to 1

**Note 2:**

Average erase count / MAX erase count (SLC 100000, MLC 5000) \* 100 (percentage)

### 5.1.2.2 Off-line Mode

SSD’s support the optional 28-bit S.M.A.R.T. EXECUTION OFF-LINE IMMEDIATE (B0h/D4h) command per the ATA-8 specification. This command causes the SSD to initiate the collection of S.M.A.R.T. data in an off-line mode and then preserves this data across power and reset events. Supported subcommands include those shown in the table below. Reference the ATA-8 specification for subcommand detail.

**Table 5-6: Supported S.M.A.R.T. EXECUTE OFF-LINE IMMEDIATE Subcommands**

Value	Description
00h	Execute S.M.A.R.T. off-line routine immediately in off-line mode
01h	Execute S.M.A.R.T. Short self-test routine immediately in off-line mode
02h	Execute S.M.A.R.T. Extended self-test routine immediately in off-line mode
04h	Execute S.M.A.R.T. Selective self-test routine immediately in off-line mode
7Fh	Abort off-line mode self-test routine
81h	Execute S.M.A.R.T. Short self-test routine immediately in captive mode
82h	Execute S.M.A.R.T. Extended self-test routine immediately in captive mode
84h	Execute S.M.A.R.T. Selective self-test routine immediately in captive mode

## 5.2 SATA Commands

The SATA 2.6 specification is a super set of the ATA/ATAPI-7 specification with regard to supported commands. SSD's support the following features that are unique to the SATA specification.

### 5.2.1 Native Command Queuing (NCQ)

SSD's support the Native Command Queuing (NCQ) command set, which consists of

- READ FPDMA QUEUED
- WRITE FPDMA QUEUED

**Note:** With a maximum queue depth less than or equal to 32.

## 6 References

- Serial ATA Specification, Revision 3

Manual	12/6/18
PSFS2xxxxZxxx	Viking Technology
Revision G	Page 30 of 31

## 7 Glossary

This document incorporates many industry and device-specific words. Use the following list to define a variety of terms and acronyms.

Term	Definition
ATA	Advanced Technology Attachment
ATAPI	Advanced Technology Attachment Packet Interface
BER	Bit error rate, or percentage of bits that have errors relative to the total number of bits received
DIPM	Device Initiated Link Power Management. The ability of the device to request SATA link power state changes.
DMA	Direct Memory Access
eMLC	Enterprise Multi-Level Cell
EXT	Extended
FP	First Party
GB	Giga-byte defined as $1 \times 10^9$ bytes
HDD	Hard Disk Drive
Hot Plug	A term used to describe the removal or insertion of a SATA storage drive when the system is powered on.
IOPS	Input output operations per second
LBA	Logical Block Address
MB	Mega-bytes defined as $1 \times 10^6$ bytes
MLC	Multi-Level Cell
MTBF	Mean Time Between Failures
NCQ	Native Command Queuing. The ability of the SATA hard drive to queue and re-order commands to maximize execution efficiency.
NOP	No Operation
OS	Operating System
Port	The point at which a SATA drive physically connects to the SATA controller.
RMS	Root Mean Squared
RPM	Revolutions Per Minute
SAS	Serial Attached SCSI
SATA	Serial ATA
SFF	Small Form Factor
SLC	Single Level Cell
S.M.A.R.T.	Self-Monitoring, Analysis and Reporting Technology: an open standard for developing hard drives and software systems that automatically monitors a hard drive's health and reports potential problems.
SSD	Solid-State Drive