

# DDR4 (PC4) ECC ULP MINI-UDIMM VR9ZUxx72x8xxx

The Viking DDR4 MINI-UDIMM memory module offers lower operating voltages, higher module densities and faster speed categories than the prior DDR3 generation. JEDEC DDR4 (JESD79-4) has been defined to provide higher performance, with improved reliability and reduced power, thereby representing a significant achievement relative to previous DRAM memory technologies.

|                |                   |
|----------------|-------------------|
| Datasheet      | 5/11/2017         |
| PS9ZUxx72x8xxx | Viking Technology |
| Revision D     | Page 1 of 40      |

## REVISION HISTORY

| Revision | Release Date | Description of Change  | Checked By (Full Name) |
|----------|--------------|--|------------------------|
| A        | 9/11/15      | Initial release (modified VR9WRxx72x8xxx_A).<br>1. Add Note 4 on Mechanical outline<br>2. update height for ULP Mini DIMM in Detail W.<br>3. add ECC DRAM to functional Block Diagram,<br>4. 8Gbit IDD values per PS9FRxx72x8xxx_A | IDC                    |
| B        | 1/16/2016    | Add 16 GB Pn's and IDD values  |                        |
| C        | 4/6/2016     | Add update to max ratings  |                        |
| D        | 5/11/17      | Revise logo and color scheme. Change company address   |                        |
|          |              |  |                        |

|                |                   |
|----------------|-------------------|
| Datasheet      | 5/11/2017         |
| PS9ZUxx72x8xxx | Viking Technology |
| Revision D     | Page 2 of 40      |

## Legal Information

### Legal Information

Copyright© 2017 Sanmina Corporation. All rights reserved. The information in this document is proprietary and confidential to Sanmina Corporation. No part of this document may be reproduced in any form or by any means or used to make any derivative work (such as translation, transformation, or adaptation) without written permission from Sanmina. Sanmina reserves the right to revise this documentation and to make changes in content from time to time without obligation on the part of Sanmina to provide notification of such revision or change.

Sanmina provides this documentation without warranty, term or condition of any kind, either expressed or implied, including, but not limited to, expressed and implied warranties of merchantability, fitness for a particular purpose, and non-infringement. While the information contained herein is believed to be accurate, such information is preliminary, and should not be relied upon for accuracy or completeness, and no representations or warranties of accuracy or completeness are made. In no event will Sanmina be liable for damages arising directly or indirectly from any use of or reliance upon the information contained in this document. Sanmina may make improvements or changes in the product(s) and/or the program(s) described in this documentation at any time.

Sanmina, Viking Technology, Viking Modular Solutions, and the Viking logo are trademarks of Sanmina Corporation. Other company, product or service names mentioned herein may be trademarks or service marks of their respective owners.

### STATEMENT OF COMPLIANCE

Viking Technology, Sanmina Corporation ("Viking") shall use commercially reasonable efforts to provide components, parts, materials, products and processes to Customer that do not contain: (i) lead, mercury, hexavalent chromium, polybrominated biphenyls (PBB) and polybrominated diphenyl ethers (PBDE) above 0.1% by weight in homogeneous material or (ii) cadmium above 0.01% by weight of homogeneous material, except as provided in any exemption(s) from RoHS requirements (including the most current version of the "Annex" to Directive 2002/95/EC of 27 January, 2003), as codified in the specific laws of the EU member countries. Viking strives to obtain appropriate contractual protections from its suppliers in connection with the RoHS Directives.

All printed circuit boards (PCBs) have a flammability rating of UL94V-0.

|                |                   |
|----------------|-------------------|
| Datasheet      | 5/11/2017         |
| PS9ZUxx72x8xxx | Viking Technology |
| Revision D     | Page 3 of 40      |

## 288 pin Ordering Information and Module Configuration

| Viking Part Number | Voltage | Capacity | Module Configuration | Device Configuration | Device Package | DIMM Ranks | Speed     | CAS Latency     |
|--------------------|---------|----------|----------------------|----------------------|----------------|------------|-----------|-----------------|
| VR9ZU127228HBGyz   | 1.2V    | 4GB      | 512Mx72              | 512Mx8 (9)           | 4Gb FBGA       | 1          | PC4-14900 | CL13 (13-13-13) |
| VR9ZU127228HBHyz   | 1.2V    | 4GB      | 512Mx72              | 512Mx8 (9)           | 4Gb FBGA       | 1          | PC4-17000 | CL15 (15-15-15) |
| VR9ZU127228HBJyz   | 1.2V    | 4GB      | 512Mx72              | 512Mx8 (9)           | 4Gb FBGA       | 1          | PC4-19200 | CL17 (17-17-17) |
| VR9ZU1G7228JBGyz   | 1.2V    | 8GB      | 1Gx72                | 1024Mx8 (9)          | 8Gb FBGA       | 1          | PC4-14900 | CL13 (13-13-13) |
| VR9ZU1G7228JBHyz   | 1.2V    | 8GB      | 1Gx72                | 1024Mx8 (9)          | 8Gb FBGA       | 1          | PC4-17000 | CL15 (15-15-15) |
| VR9ZU1G7228JBJyz   | 1.2V    | 8GB      | 1Gx72                | 1024Mx8 (9)          | 8Gb FBGA       | 1          | PC4-19200 | CL17 (17-17-17) |
| VR9ZU2G7228JEGyz   | 1.2V    | 16GB     | 2Gx72                | 1024Mx8 (9)          | 8Gb DDP        | 2          | PC4-14900 | CL13 (13-13-13) |
| VR9ZU2G7228JEHyz   | 1.2V    | 16GB     | 2Gx72                | 1024Mx8 (9)          | 8Gb DDP        | 2          | PC4-17000 | CL15 (15-15-15) |
| VR9ZU2G7228JEJyz   | 1.2V    | 16GB     | 2Gx72                | 1024Mx8 (9)          | 8Gb DDP        | 2          | PC4-19200 | CL17 (17-17-17) |

### Notes:

1. Contact Viking for availability date
2. The lowercase letters y and z are wildcard characters that indicate DRAM vendor and die revisions and /or for customer specific locked BOMs. Refer to the Viking part number coversheet for details.

|                |                   |
|----------------|-------------------|
| Datasheet      | 5/11/2017         |
| PS9ZUxx72x8xxx | Viking Technology |
| Revision D     | Page 4 of 40      |

## Features

- JEDEC Standard Power Supply
  - PC4: VDD = VDDQ = 1.2V± 5% (1.14V-1.26V)
  - External VPP = 2.5 Volt +10%, -5%
  - VDDSPD = 2.5V± 10% (2.25-2.75V)
- 288 pin Dual-In-Line Memory Module
- Edge finger connector ramp zone to reduce insertion force
- Point-to-Point topology to reduce loading
- Pseudo-open drain (POD12) DQ lines
- Internally generated VrefDQ
- ECC recovery from command and parity errors
- On-chip CA Parity detection for the command/address bus
- Programmable CAS Latency: 13,15,16
- Programmable CAS Write Latency (CWL).
- Programmable Additive Latency (Posted CAS)
- Per DRAM addressability is supported
- Data Bus Inversion support for x8 devices
- Selectable Fixed burst chop (BC4) of 4 and burst length (BL8) of 8 on-the-fly (OTF) via the mode register set (MRS)
- 8n prefetch with 2 or 4 selectable bank groups: 16 banks (4 bank groups x 4 banks per bank group)
- Separate activation, read, write, refresh operations for each bank group
- 7 mode registers
- Dynamic On-Die-Termination (ODT) and ODT Park for improved signal integrity.
- Self Refresh and several Power Down Modes
- DLL-off mode for power savings
- System Level Timing Calibration Support via Write Leveling and Multi Purpose Register (MPR) Read Pattern
- Serial Presence Detect with EEPROM
- Two On-DIMM Thermal Sensors
- Asynchronous Reset
- Bidirectional Differentially Buffered Data Strobes(DQS)
- MINI-UDIMM dimensions per JEDEC MO-314
- RoHS Compliant

## DDR4 SPEED BIN Nomenclature

| Module Standard         | SDRAM Standard | Clock    |
|-------------------------|----------------|----------|
| DDR4-14900              | DDR4-1866      | 933 MHz  |
| DDR4-17000              | DDR4-2133      | 1066 MHz |
| DDR4-19200 <sup>1</sup> | DDR4-2400      | 1200 MHz |

### Notes:

1. Contact Viking for availability date

## DDR4 Timing Summary

| MT/s             | tCK (ns) | CAS Latency (tCK) | tRCD (ns) | tRP (ns) | tRAS (ns) | tRC (ns) | CL-tRCD-tRP |
|------------------|----------|-------------------|-----------|----------|-----------|----------|-------------|
| <b>DDR4-1866</b> | 1.071    | 13                | 13.92     | 13.92    | 34        | 47.92    | 13-13-13    |
| <b>DDR4-2133</b> | 0.93     | 15                | 14.06     | 14.06    | 33        | 47.05    | 15-15-15    |
| <b>DDR4-2400</b> | 0.83     | 17                | 14.16     | 14.16    | 32        | 46.16    | 17-17-17    |

### Notes:

- CL = CAS Latency, tRCD = Activate –to-Command Time, tRP = Precharge Time. Refer to Speed Bin tables for details.

|                |                   |
|----------------|-------------------|
| Datasheet      | 5/11/2017         |
| PS9ZUxx72x8xxx | Viking Technology |
| Revision D     | Page 5 of 40      |

## Addressing

|                |                      | 4GB(1Rx8)<br>512Mx8 DRAM | 8GB(1Rx8)<br>1024Mx8 DRAM |
|----------------|----------------------|--------------------------|---------------------------|
| Bank Address   | # of Bank Groups     | 4                        | 4                         |
|                | BG Address           | BG0~BG1                  | BG0~BG1                   |
|                | Bank Address in a BG | BA0~BA1                  | BA0~BA1                   |
| Row Address    |                      | A0~A14                   | A0~A15                    |
| Column Address |                      | A0~ A9                   | A0~ A9                    |
| Page size      |                      | 1KB                      | 1KB                       |

## DDR4 288-pin MINI-UDIMM Pin Wiring Assignments/Configurations

| FRONT SIDE |         |     |         |     |                     |     |        | BACK SIDE |                               |     |                               |     |               |     |                               |
|------------|---------|-----|---------|-----|---------------------|-----|--------|-----------|-------------------------------|-----|-------------------------------|-----|---------------|-----|-------------------------------|
| Pin        | Name    | Pin | Name    | Pin | Name                | Pin | Name   | Pin       | Name                          | Pin | Name                          | Pin | Name          |     |                               |
| 1          | 12V/ NC | 37  | VSS     | 73  | A1                  | 109 | DQ41   | 145       | VREFCA                        | 181 | VSS                           | 217 | RFU           | 253 | DQ45                          |
| 2          | 12V/ NC | 38  | DQ24    | 74  | VDD                 | 110 | VSS    | 146       | SAVE_n,<br>NC                 | 182 | DQ28                          | 218 | VDD           | 254 | VSS                           |
| 3          | RFU     | 39  | VSS     | 75  | CK0_t               | 111 | DQS5_c | 147       | RFU                           | 183 | VSS                           | 219 | CK1_t         | 255 | TDQS14_t/<br>DBI5_n/<br>DM5_n |
| 4          | VSS     | 40  | DQ25    | 76  | CK0_c               | 112 | DQS5_t | 148       | VSS                           | 184 | DQ29                          | 220 | CK1_c         | 256 | TDQS14_c                      |
| 5          | DQ0     | 41  | VSS     | 77  | VDD                 | 113 | VSS    | 149       | DQ4                           | 185 | VSS                           | 221 | VDD           | 257 | VSS                           |
| 6          | VSS     | 42  | DQS3_c  | 78  | RFU                 | 114 | DQ42   | 150       | VSS                           | 186 | TDQS12_t/<br>DBI3_n/<br>DM3_n | 222 | RFU           | 258 | DQ46                          |
| 7          | DQ1     | 43  | DQS3_t  | 79  | VTT<br>EVENT_n      | 115 | VSS    | 151       | DQ5                           | 187 | TDQS12_c                      | 223 | VTT           | 259 | VSS                           |
| 8          | VSS     | 44  | VSS     | 80  |                     | 116 | DQ43   | 152       | VSS                           | 188 | VSS                           | 224 | PARITY        | 260 | DQ47                          |
| 9          | DQS0_c  | 45  | DQ26    | 81  | VDD                 | 117 | VSS    | 153       | TDQS9_t/<br>DBI0_n/<br>DM0_n  | 189 | DQ30                          | 225 | VDD           | 261 | VSS                           |
| 10         | DQS0_t  | 46  | VSS     | 82  | A0                  | 118 | DQ48   | 154       | TDQS9_c                       | 190 | VSS                           | 226 | BA1           | 262 | DQ52                          |
| 11         | VSS     | 47  | DQ27    | 83  | BA0                 | 119 | VSS    | 155       | VSS                           | 191 | DQ31                          | 227 | A10/<br>AP    | 263 | VSS                           |
| 12         | DQ2     | 48  | VSS     | 84  | VDD                 | 120 | DQ49   | 156       | DQ6                           | 192 | VSS                           | 228 | VDD           | 264 | DQ53                          |
| 13         | VSS     | 49  | CB0     | 85  | RAS_n/<br>A16       | 121 | VSS    | 157       | VSS                           | 193 | CB4                           | 229 | WE_n/<br>A14  | 265 | VSS                           |
| 14         | DQ3     | 50  | VSS     | 86  | CS0_n               | 122 | DQS6_c | 158       | DQ7                           | 194 | VSS                           | 230 | CAS_n/<br>A15 | 266 | TDQS15/<br>DBI6_n/<br>DM6_n   |
| 15         | VSS     | 51  | CB1     | 87  | VDD                 | 123 | DQS6_t | 159       | VSS                           | 195 | CB5                           | 231 | VDD           | 267 | TDQS15                        |
| 16         | DQ8     | 52  | VSS     | 88  | ODT0                | 124 | VSS    | 160       | DQ12                          | 196 | VSS                           | 232 | A13           | 268 | VSS                           |
| 17         | VSS     | 53  | DQS8_c  | 89  | CS1_n               | 125 | DQ50   | 161       | VSS                           | 197 | TDQS17_t/<br>DBI8_n/<br>DM8_n | 233 | A17*          | 269 | DQ54                          |
| 18         | DQ9     | 54  | DQS8_t  | 90  | VDD                 | 126 | VSS    | 162       | DQ13                          | 198 | TDQS17_c                      | 234 | VDD           | 270 | VSS                           |
| 19         | VSS     | 55  | VSS     | 91  | ODT1                | 127 | DQ51   | 163       | VSS                           | 199 | VSS                           | 235 | C1            | 271 | DQ55                          |
| 20         | DQS1_c  | 56  | CB2, NC | 92  | C0,<br>CS2_n,<br>NC | 128 | VSS    | 164       | TDQS10_t/<br>DBI1_n/<br>DM1_n | 200 | CB6                           | 236 | C2            | 272 | VSS                           |
| 21         | DQS1_t  | 57  | VSS     | 93  | VDD                 | 129 | DQ56   | 165       | TDQS10_c                      | 201 | VSS                           | 237 | VDD           | 273 | DQ60                          |
| 22         | VSS     | 58  | CB3     | 94  | RFU                 | 130 | VSS    | 166       | VSS                           | 202 | CB7                           | 238 | RFU           | 274 | VSS                           |
| 23         | DQ10    | 59  | VSS     | 95  | VSS                 | 131 | DQ57   | 167       | DQ14                          | 203 | VSS                           | 239 | VSS           | 275 | DQ61                          |
| 24         | VSS     | 60  | ALERT_n | 96  | DQ32                | 132 | VSS    | 168       | VSS                           | 204 | RESET_n                       | 240 | DQ36          | 276 | VSS                           |

| FRONT SIDE |        |     |              |     |        |     |            | BACK SIDE |                               |     |      |     |                               |     |                               |
|------------|--------|-----|--------------|-----|--------|-----|------------|-----------|-------------------------------|-----|------|-----|-------------------------------|-----|-------------------------------|
| Pin        | Name   | Pin | Name         | Pin | Name   | Pin | Name       | Pin       | Name                          | Pin | Name | Pin | Name                          | Pin | Name                          |
| 25         | DQ11   | 61  | CKE0         | 97  | VSS    | 133 | DQS7_c     | 169       | DQ15                          | 205 | RFU  | 241 | VSS                           | 277 | TDQS16_t/<br>DBI7_n/<br>DM7_n |
| 26         | VSS    | 62  | VDD          | 98  | DQ33   | 134 | DQS7_t     | 170       | VSS                           | 206 | VDD  | 242 | DQ37                          | 278 | TDQS16_c                      |
| 27         | DQ16   | 63  | ACT_n        | 99  | VSS    | 135 | VSS        | 171       | DQ20                          | 207 | CKE1 | 243 | VSS                           | 279 | VSS                           |
| 28         | VSS    | 64  | BG0          | 100 | DQS4_c | 136 | DQ58       | 172       | VSS                           | 208 | BG1  | 244 | TDQS13_t/<br>DBI4_n/<br>DM4_n | 280 | DQ62                          |
| 29         | DQ17   | 65  | VDD          | 101 | DQS4_t | 137 | VSS        | 173       | DQ21                          | 209 | VDD  | 245 | TDQS13_c                      | 281 | VSS                           |
| 30         | VSS    | 66  | A12/<br>BC_n | 102 | VSS    | 138 | DQ59       | 174       | VSS                           | 210 | A11  | 246 | VSS                           | 282 | DQ63                          |
| 31         | DQS2_c | 67  | A9           | 103 | DQ34   | 139 | VSS        | 175       | TDQS11_t/<br>DBI2_n/<br>DM2_n | 211 | A7   | 247 | DQ38                          | 283 | VSS                           |
| 32         | DQS2_t | 68  | VDD          | 104 | VSS    | 140 | SA0        | 176       | TDQS11_c                      | 212 | VDD  | 248 | VSS                           | 284 | SA1                           |
| 33         | VSS    | 69  | A8           | 105 | DQ35   | 141 | VDDSP<br>D | 177       | VSS                           | 213 | A5   | 249 | DQ39                          | 285 | SA2                           |
| 34         | DQ18   | 70  | A6           | 106 | VSS    | 142 | SDA        | 178       | DQ22                          | 214 | A4   | 250 | VSS                           | 286 | SCL                           |
| 35         | VSS    | 71  | VDD          | 107 | DQ40   | 143 | VPP        | 179       | VSS                           | 215 | VDD  | 251 | DQ44                          | 287 | VPP                           |
| 36         | DQ19   | 72  | A3           | 108 | VSS    | 144 | VPP        | 180       | DQ23                          | 216 | A2   | 252 | VSS                           | 288 | VPP                           |

**Notes:**

1. VPP is 2.5V DC
2. Only x8 and x16 DRAM support Data Mask (DM) and Data Bus Inversion (DBI). Only x8 DRAM support TDQS
3. DM, DBI & TDQS functions are supported with dedicated one pin labeled as DM\_n/DBI\_n/TDQS\_t.

MR bit location is bit A11 in MR1 and bit A12:A10 in MR5 . Write operation: Either DM or DBI function can be enabled but both functions cannot be enabled simultaneously. When both DM and DBI functions are disabled, DRAM turns off its input receiver and does not expect any valid logic level. Read operation: Only DBI function applies. When DBI function is disabled, DRAM turns off its output driver and does not drive any valid logic level. TDQS function: When TDQS function is enabled, DM & DBI functions are not supported. When TDQS function is disabled, When enabled, the same termination resistance function is applied to the TDQS\_t/TDQS\_c pins that is applied to DQS\_t/DQS\_c pins. DM, DBI & TDQS functions are described in more detail on x8 based datasheets

|                |                   |
|----------------|-------------------|
| Datasheet      | 5/11/2017         |
| PS9ZUxx72x8xxx | Viking Technology |
| Revision D     | Page 8 of 40      |



## Input/Output Functional Descriptions

| Symbol  | Type             | Function   |
|---|------------------|--|
| CK_t, CK_c  | Input            | Clock: CK_t and CK_c are differential clock inputs. All address and control input signals are sampled on the crossing of the positive edge of CK_t and negative edge of CK_c.  |
| CKE0, (CKE1)  | Input            | Clock Enable: CKE HIGH activates, and CKE Low deactivates, internal clock signals and device input buffers and output drivers. Taking CKE Low provides Precharge Power-Down and Self-Refresh operation (all banks idle), or Active Power-Down (row Active in any bank). CKE is asynchronous for Self-Refresh exit. After VREFCA and VREFDQ have become stable during the power on and initialization sequence, they must be maintained during all operations (including Self-Refresh). CKE must be maintained high throughout read and write accesses. Input buffers, excluding CK, CK_c, ODT and CKE, are disabled during power-down. Input buffers, excluding CKE, are disabled during Self-Refresh. |
| CS0_n, (CS1_n)  | Input            | Chip Select: All commands are masked when CS_n is registered HIGH. CS_n provides for external Rank selection on systems with multiple Ranks. CS_n is considered part of the command code.  |
| C0,C1,C2  | Input            | Chip ID: Chip ID is only used for 3DS for 2,4,8high stack via TSV to select each slice of stacked component. Chip ID is considered part of the command code.   |
| ODT0, (ODT1)  | Input            | On Die Termination: ODT (registered HIGH) enables termination resistance internal to the DDR4 SDRAM. When enabled, ODT is only applied to each DQ, DQS_t, DQS_c and DM_n/DBI_n/TDQS_t,NU/TDQS_c (When TDQS is enabled via Mode Register A11=1 in MR1) signal for x8 configurations. For x16 configuration ODT is applied to each DQ, DQSU_c, DQSU_t, DQSL_t, DQSL_c, DMU_n, and DML_n signal. The ODT pin will be ignored if MR1 is programmed to disable RTT_NOM.   |
| ACT_n   | Input            | Activation Command Input: ACT_n defines the Activation command being entered along with CS_n. The input into RAS_n/A16, CAS_n/A15 and WE_n/A14 will be considered as Row Address A16, A15 and A14.   |
| RAS_n/A16,<br>CAS_n/A15,<br>WE_n/A14                        | Input            | Command Inputs RAS_n/A16, CAS_n/A15 and WE_n/A14 (along with CS_n) define the command being entered. Those pins have multi function. For example, for activation with ACT_n Low, those are Addressing like A16,A15 and A14 but for non-activation command with ACT_n High, those are Command pins for Read, Write and other command defined in command truth table.  |
| DM_n/DBI_n/<br>TDQS_t,<br>(DMU_n/DBIU_n),<br>(DML_n/DBIL_n) | Input/<br>Output | Input Data Mask and Data Bus Inversion: DM_n is an input mask signal for write data. Input data is masked when DM_n is sampled LOW coincident with that input data during a Write access. DM_n is sampled on both edges of DQS. DM is muxed with DBI function by Mode Register A10,A11,A12 setting in MR5. For x8 device, the function of DM or TDQS is enabled by Mode Register A11 setting in MR1. DBI_n is an input/output identifying whether to store/output the true or inverted data. If DBI_n is LOW, the data will be stored/output after inversion inside the DDR4 SDRAM and not inverted if DBI_n is HIGH. TDQS is only supported in x8.  |
| BG0 - BG1   | Input            | Bank Group Inputs: BG0 - BG1 define to which bank group an Active, Read, Write or Precharge command is being applied. BG0 also determines which mode register is to be accessed during a MRS cycle. x4/8 have BG0 and BG1 but x16 has only BG0.  |

|                |                   |
|----------------|-------------------|
| Datasheet      | 5/11/2017         |
| PS9ZUxx72x8xxx | Viking Technology |
| Revision D     | Page 9 of 40      |

## Input/Output Functional Descriptions (cont.)

| Symbol                                       | Type           | Function  |
|--|----------------|---|
| BA0 - BA1                                    | Input          | Bank Address Inputs: BA0 - BA1 define to which bank an Active, Read, Write or Precharge command is being applied. Bank address also determines if the mode register or extended mode register is to be accessed during a MRS cycle.   |
| A0 - A17                                     | Input          | Address Inputs: Provided the row address for ACTIVATE Commands and the column address for Read/Write commands to select one location out of the memory array in the respective bank. (A10/AP, A12/BC_n, RAS_n/A16, CAS_n/A15 and WE_n/A14 have additional functions, see other rows. The address inputs also provide the op-code during Mode Register Set commands. A17 is only defined for the x4 configuration.   |
| A10 / AP                                     | Input          | Auto-precharge: A10 is sampled during Read/Write commands to determine whether Autoprecharge should be performed to the accessed bank after the Read/Write operation. (HIGH: Autoprecharge; LOW: no Autoprecharge). A10 is sampled during a Precharge command to determine whether the Precharge applies to one bank (A10 LOW) or all banks (A10 HIGH). If only one bank is to be precharged, the bank is selected by bank addresses.   |
| A12 / BC_n                                   | Input          | Burst Chop: A12 / BC_n is sampled during Read and Write commands to determine if burst chop (on-the-fly) will be performed. (HIGH, no burst chop; LOW: burst chopped). See command truth table for details.   |
| RESET_n                                      | Input          | Active Low Asynchronous Reset: Reset is active when RESET_n is LOW, and inactive when RESET_n is HIGH. RESET_n must be HIGH during normal operation. RESET_n is a CMOS rail to rail signal with DC high and low at 80% and 20% of VDD.  |
| DQ   | Input / Output | Data Input/ Output: Bi-directional data bus. If CRC is enabled via Mode register then CRC code is added at the end of Data Burst. Any DQ from DQ0~DQ3 may indicate the internal Vref level during test via Mode Register Setting MR4 A4=High. Refer to vendor specific datasheets to determine which DQ is used.  |
| CB   | Input / Output | Check Bit Input/ Output: Bi-directional ECC portion of data bus for x72 configurations  |
| DQS_t, DQS_c, DQSU_t, DQSU_c, DQSL_t, DQSL_c | Input / Output | Data Strobe: output with read data, input with write data. Edge-aligned with read data, centered in write data. For x16, DQSL corresponds to the data on DQL0-DQL7; DQSU corresponds to the data on DQU0-DQU7. The data strobe DQS_t, DQSL_t, and DQSU_t are paired with differential signals DQS_c, DQSL_c, and DQSU_c, respectively, to provide differential pair signaling to the system during reads and writes. DDR4 SDRAM supports differential data strobe only and does not support single-ended. |

|                |                   |
|----------------|-------------------|
| Datasheet      | 5/11/2017         |
| PS9ZUxx72x8xxx | Viking Technology |
| Revision D     | Page 10 of 40     |

### Input/Output Functional Descriptions (cont.)

| Symbol  | Type   | Function   |
|---------|--------|--|
| ALERT_n | Output | Alert: It has multi functions such as CRC error flag, Command and Address Parity error flag. If there is error in CRC, then Alert_n goes LOW for the period time interval and goes back HIGH. IF there is error in Command Address Parity Check, then Alert_n goes LOW for relatively long period until on going DRAM internal recovery transaction to complete. |
| TEN     | Input  | Boundary Scan Mode Enable: Required on x16 devices and optional input on x4/x8 with densities equal to or greater than 8Gb. HIGH in this pin will enable boundary scan operation along with other pins. It is a CMOS rail to rail signal with DC high and low at 80% and 20% of VDD.   |
| NC      |        | No Connect: No internal electrical connection is present.  |
| VDDQ    | Supply | DQ Power Supply: 1.2 V +/- 0.06 V  |
| VSSQ    | Supply | DQ Ground  |
| VDD     | Supply | Power Supply: 1.2 V +/- 0.06 V   |
| VSS     | Supply | Ground   |
| Vpp     | Supply | DRAM Activation Power Supply: 2.5V (2.375V min , 2.75 max)   |
| VREFCA  | Supply | Reference voltage for CA   |
| ZQ      | Supply | Reference Pin for ZQ calibration   |

**Note:**  
 The input only pins (BG0-BG-1, BA0-BA1, A0-A17, ACT\_n, RAS\_n/A16, CAS\_n/A15, WE\_n/A14, CS\_n, CKE, ODT, and RESET\_n) do not supply termination.

### MECHANICAL OUTLINE

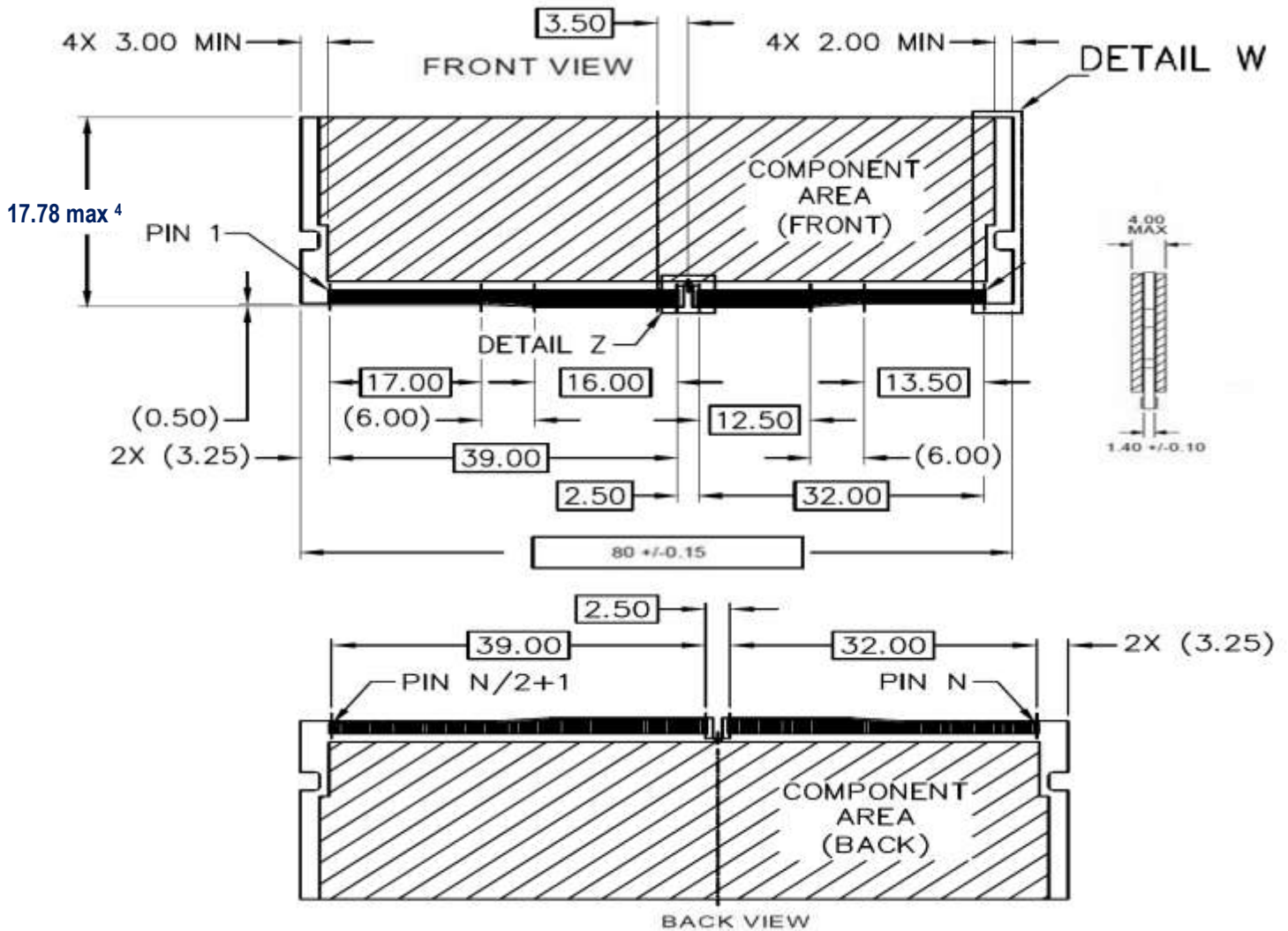

**Notes:**

1. All dimensions in mm.
2. Tolerance is +/- 0.15 mm, unless otherwise stated.
3. Refer to JEDEC Standard Mechanical Outline MO-314A spec for other details.
4. MO 314A height for VLP is 18.75(Nominal). ULP Mini Dimm is 18.75 - 1mm = 17.75 (nominal)

|                |                   |
|----------------|-------------------|
| Datasheet      | 5/11/2017         |
| PS9ZUxx72x8xxx | Viking Technology |
| Revision D     | Page 12 of 40     |

DETAIL W:

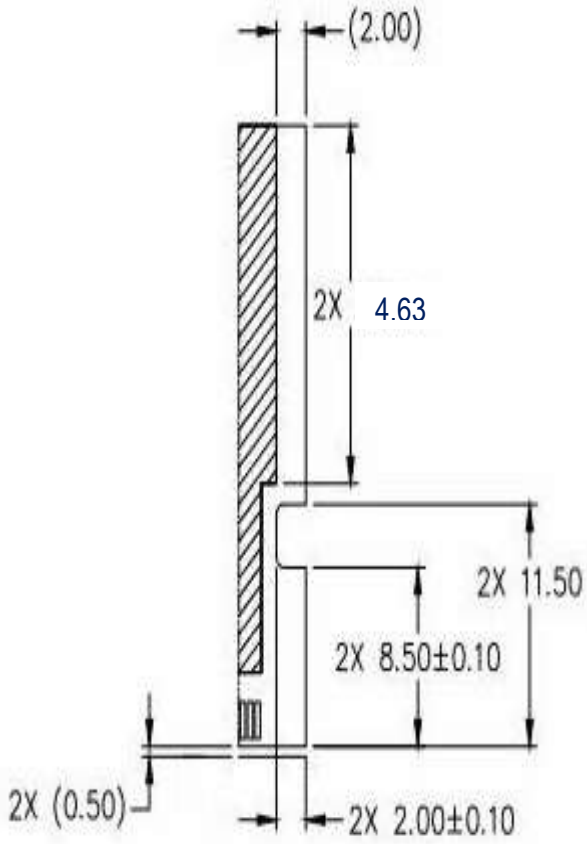

DETAIL Z:

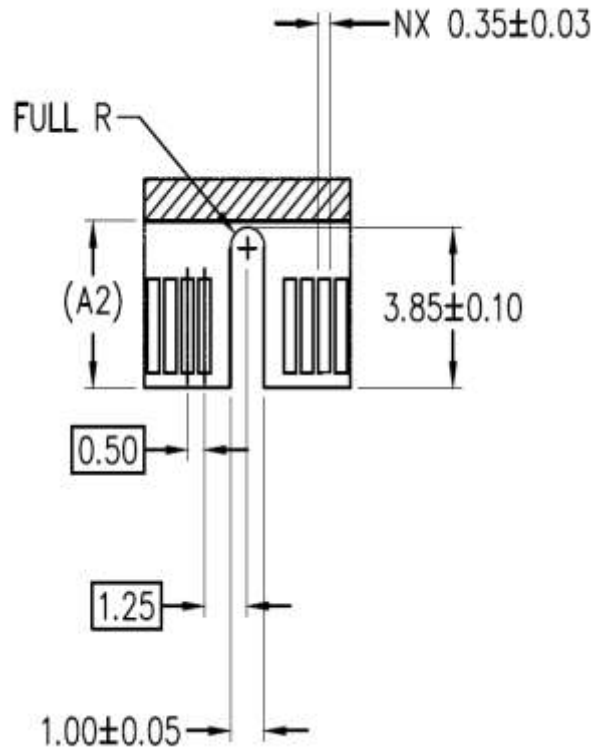

**Notes:**

1. All dimensions in mm
2. Tolerance is +/- 0.15 mm, unless otherwise stated.
3. Refer to JEDEC Standard Mechanical Outline MO-314A spec for other details

|                |                   |
|----------------|-------------------|
| Datasheet      | 5/11/2017         |
| PS9ZUxx72x8xxx | Viking Technology |
| Revision D     | Page 13 of 40     |

## FUNCTIONAL BLOCK DIAGRAM

Signal Groups:

1. Clock (CK)
2. Address, Bank Address, Bank Group and Command (ADD/CMD)
3. Control (CTRL)
4. Data Bus (including ECC byte) (DQ)

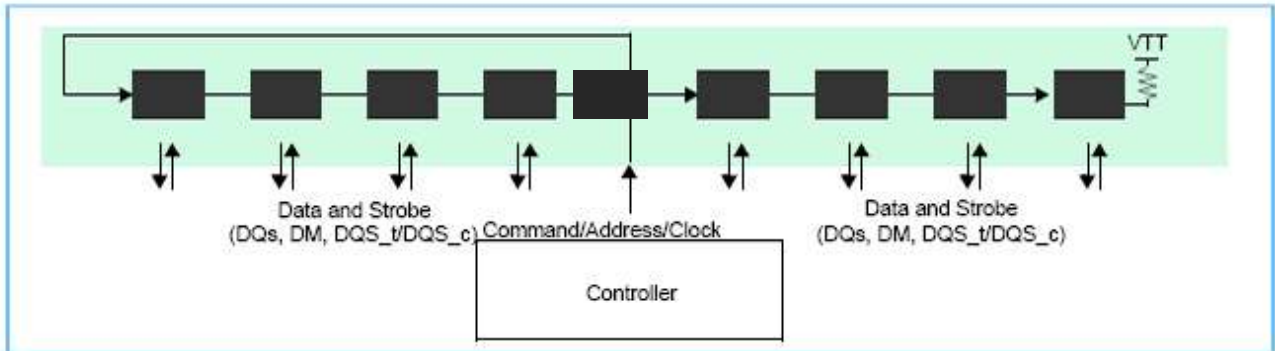

|                       |   |                                   |
|-----------------------|---|-----------------------------------|
| BA[1:0]               | → | BA[1:0]: DDR4 SDRAM               |
| BG[1:0]               | → | BG[1:0]: DDR4 SDRAM               |
| ACT <sub>n</sub>      | → | ACT <sub>n</sub> : DDR4 SDRAM     |
| A[13:0]               | → | A[13:0]: DDR4 SDRAM               |
| RAS <sub>n</sub> /A16 | → | RAS <sub>n</sub> /A16: DDR4 SDRAM |
| CAS <sub>n</sub> /A15 | → | CAS <sub>n</sub> /A15: DDR4 SDRAM |
| WE <sub>n</sub> /A14  | → | WE <sub>n</sub> /A14: DDR4 SDRAM  |
| CKE0                  | → | CKE0: Rank 0                      |
| CKE1                  | → | CKE1: Rank 1                      |
| ODT0                  | → | ODT0: Rank 0                      |
| ODT1                  | → | ODT1: Rank 1                      |
| RESET                 | → | RESET <sub>n</sub> : DDR4 SDRAM   |
| PARITY                | → | PARITY: DDR4 SDRAM                |
| ALERT <sub>n</sub>    | ← | ALERT <sub>n</sub> : DDR4 SDRAM   |

$V_{DD}$   
 $\approx 50\Omega$

|                |                   |
|----------------|-------------------|
| Datasheet      | 5/11/2017         |
| PS9ZUxx72x8xxx | Viking Technology |
| Revision D     | Page 14 of 40     |

Rank 0: U1–U8  
Rank 1: U10–U17

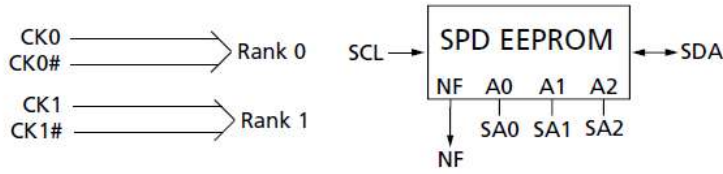

Clock, control, command, and address line terminations:

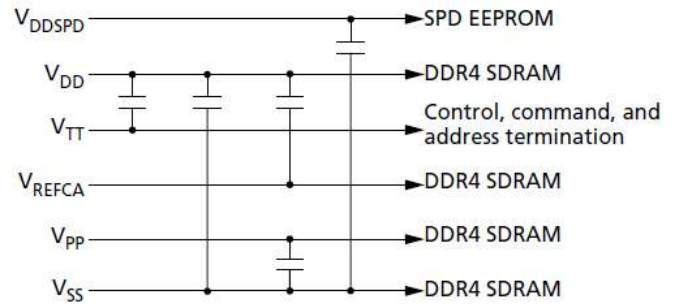
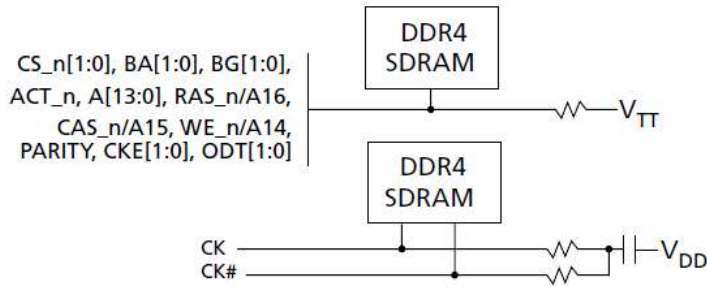

**Notes:**

- The ZQ ball on each DDR4 component is connected to an external 240Ω ±1% resistor that is tied to ground. It is used for the calibration of the component's ODT and output driver.

|                |                   |
|----------------|-------------------|
| Datasheet      | 5/11/2017         |
| PS9ZUxx72x8xxx | Viking Technology |
| Revision D     | Page 15 of 40     |



## DQ Internal Vref Specifications

| Parameter                        | Symbol          | Min     | Typ   | Max   | Unit | NOTE  |
|----------------------------------|-----------------|---------|-------|-------|------|-------|
| Vref Max operating point Range 1 | Vref_max_R1     | -       | -     | 92%   | VDDQ | 1, 11 |
| Vref Min operating point Range 1 | Vref_min_R1     | 60%     | -     | -     | VDDQ | 1,11  |
| Vref Max operating point Range 2 | Vref_max_R2     | -       | -     | 77%   | VDDQ | 1, 11 |
| Vref Min operating point Range 2 | Vref_min_R2     | 45%     | -     | -     | VDDQ | 1,11  |
| Vref Stepsize                    | Vref_step       | 0.50%   | 0.65% | 0.80% | VDDQ | 2     |
| Vref Set Tolerance               | Vref_set_tol    | -1.625% | 0.00% | 1.63% | VDDQ | 3,4,6 |
|                                  |                 | -0.15%  | 0.00% | 0.15% | VDDQ | 3,5,7 |
| Vref Step Time                   | Vref_time-long  | -       | -     | 150   | ns   | 9     |
|                                  | Vref_time-Short | -       | -     | 60    | ns   | 8     |
| Vref Valid tolerance             | Vref_val_tol    | -0.15%  | 0.00% | 0.15% | VDDQ | 10    |

### Notes:

1. JESD8-24 specifies Vref to be 70% of VDDQ. Vref DC voltage referenced to VDDQ\_DC. VDDQ\_DC is 1.2V
2. Vref stepsize increment/decrement range. Vref at DC level.
3.  $Vref\_new = Vref\_old + n * Vref\_step$ ; n=number of step; if increment use "+"; If decrement use "-"
4. The minimum value of Vref setting tolerance= $Vref\_new - 1.625% * VDDQ$ .  
The maximum value of Vref setting tolerance= $Vref\_new + 1.625% * VDDQ$ . For n>4
5. The maximum value of Vref setting tolerance= $Vref\_new - 0.15% * VDDQ$ .  
The maximum value of Vref setting tolerance= $Vref\_new + 0.15% * VDDQ$ . For n&4
6. Measured by recording the min and max values of the Vref output over the range, drawing a straight line between those points and comparing all other Vref output settings to that line
7. Measured by recording the min and max values of the Vref output across 4 consecutive steps(n=4), drawing a straight line between those points and comparing all other Vref output settings to that line
8. Time from MRS command to increment of decrement one step size for Vref
9. Time from MRS command to increment of decrement more than one step size up to full range of Vref
10. Only applicable for DRAM component level test/characterization purpose.  
Not applicable for normal mode of operation. Vref valid is to qualify the step times which will be characterized at the component level.
11. DRAM range1 or 2 set by MRS bit MR6,A6.

|                |                   |
|----------------|-------------------|
| Datasheet      | 5/11/2017         |
| PS9ZUxx72x8xxx | Viking Technology |
| Revision D     | Page 16 of 40     |



## OVERVIEW OF DDR4 MINI-UDIMM MODULE OPERATION

The DDR4 architecture is generally a point-to-point topology with a dedicated channel design. The highest system performance levels can be achieved with DDR4-2133 and beyond, when the system is configured as 1 MINI-UDIMM Per Channel (1DPC). DDR4 has more features than DDR3 with a pseudo-open drain (POD12) 1.2v I/O for the data channel, trained Vref, bank groups and write CRC. The POD12 interface only applies to the data channel. The address command channel behave like DDR3 using mid-point termination and mid-point Vref. The new bank group interleaving feature in DDR4 maximizes data transfer bandwidth.

DDR4 DRAM use pseudo-open drain (POD12) 1.2v drivers with Vdd terminations on DQ lines to increase data rates; unlike DDR3 DRAM that uses stub-series terminated logic drivers, The DRAM addressing scheme in DDR4 is organized into bank groups, Side A and Side B. The host DDR4 memory controller interleaves (multiplexes) among the bank groups to achieve high data rates. DDR4 architecture is a 8n prefetch with bank groups, including the use of two or four selectable bank groups. This will permit the DDR4 memory devices to have separate activation, read, write or refresh operations simultaneously underway in each of the unique bank groups to improve overall memory efficiency and bandwidth, especially when small memory granularities are used.

The data written to the MINI-UDIMM is read back the same way. However when writing to the internal registers with a "load mode" operation, a specific address is required. This requires the controller to know if the rank is mirrored or not. There is a bit assignment in the SPD that indicates whether the module has been designed with a mirrored feature or not.

DDR4 offers ECC recovery from command and parity errors to prevent the host system from crashing. The use of CRC parity is an optional feature on address command and data; (Error command blocking when parity enabled and post CA parity. If the MINI-UDIMM does not support CRC, the values of 0x00 will fill the CRC table. The new CA parity feature on the command/address bus provides a low-cost method of verifying the integrity of command and address transfers over a link, for all operations.

Some of the main attributes of DDR4 memory are:

- 1) Internally generated VrefDQ and Calibration.  
 VrefDQ is supplied by the DRAM internally.  
 VrefCA is supplied by the board.
- 2) The ACT\_n activate pin replaces RAS#, CAS#, and WE# commands,
- 3) Alert\_n for error checking
- 4) Bank group Interleaving
- 5) Improved training modes upon power-up
- 5) Nominal and dynamic ODT: Improvements to the ODT protocol and a new Park Mode allow for a nominal termination and dynamic write termination without having to drive the ODT pin
- 6) DQ bus gear-down mode for 2667 Mhz data rates and beyond
- 7) External VPP at 2.5V (for wordline boost)
- 8) 1.2V VDD power with power-saving features that include MPSM Maximum Power Savings Mode, Low Power Auto Self Refresh, Temperature Controlled Refresh, Fine Granularity Refresh, and CMD/ADDT latency. DLL off mode.

### Important Note:

Longer boot-up times may be experienced in certain situations due to controller initiated functions such as VrefDQ calibration, write leveling and other trainings for the MINI-UDIMM.

|                |                   |
|----------------|-------------------|
| Datasheet      | 5/11/2017         |
| PS9ZUxx72x8xxx | Viking Technology |
| Revision D     | Page 17 of 40     |

## DDR4 MODE REGISTERS

|            | A12                                       | A11                    | A10                               | A9                        | A8                        | A7                     | A6                    | A5                      | A4                    | A3                | A2                         | A1                    | A0         |
|------------|---|------------------------|-----------------------------------|---------------------------|---------------------------|------------------------|-----------------------|-------------------------|-----------------------|-------------------|----------------------------|-----------------------|------------|
| <b>MR0</b> | RFU                                       | Write Recovery and RTP |                                   |                           | DLL Reset                 | Test Mode              | CAS Latency CL        |                         |                       | Burst Type        | CL                         | Burst Length BL       |            |
| <b>MR1</b> | Qoff                                      | TDQS                   | Rtt_NOM                           |                           |                           | Write Leveling         | RFU                   | RFU                     | Additive Latency      |                   | Ron                        |                       | DLL Enable |
| <b>MR2</b> | Write CRC                                 | RFU                    | Rtt_WR                            |                           | RFU                       | Auto Self Refresh      |                       | CWL                     |                       |                   | RFU                        | RFU                   | RFU        |
| <b>MR3</b> | MPR Read Format                           |                        | Write CMD Latency with CRC and DM |                           | Fine Granularity Refresh  |                        |                       | Temp Sensor             | Per-DRAM Addr Mode    | Gear down         | MPR Enable                 | MPR Page              |            |
| <b>MR4</b> | Write Preamble                            | Read Preamble          | Read Preamble Training Enable     | Self Refresh Abort Enable | CS-to-Address Latency CAL |                        |                       | RFU                     | VrefDQ Monitor Enable | Temp Refresh Mode | Temp. Refresh Range        | Max Power Down Enable | RFU        |
| <b>MR5</b> | Read DBI Enable                           | Write DBI Enable       | Data Mask Enable                  | Parity Persistent Error   | Rtt_PARK                  |                        |                       | ODT input in Power Down | Panty Error Status    | CRC Error Clear   | CMD Address Parity Latency |                       |            |
| <b>MR6</b> | tCCD_L and tDLLK Timing                   |                        |                                   | RFU                       | RFU                       | VrefDQ Training enable | VrefDQ Training Range | VretDQ Training Value   |                       |                   |                            |                       |            |
| <b>MR7</b> | Manufacturing use only to program the RCD |                        |                                   |                           |                           |                        |                       |                         |                       |                   |                            |                       |            |

### Notes:

- Refer to JEDEC documentation for detail of the control/status bits

|                |                   |
|----------------|-------------------|
| Datasheet      | 5/11/2017         |
| PS9ZUxx72x8xxx | Viking Technology |
| Revision D     | Page 18 of 40     |

## DC OPERATING CONDITIONS AND CHARACTERISTICS

### ABSOLUTE MAXIMUM RATINGS

| Parameter                                | Symbol           | Value        | Unit | Notes |
|--|------------------|--------------|------|-------|
| Voltage on any pin relative to GND       | Vin, Vout        | -0.4 ~ 1.975 | V    | 1,    |
| Voltage on VDD supply relative to GND    | VDD              | -0.4 ~ 1.975 | V    | 1,3   |
| Voltage on VDDQ supply relative to GND   | VDDQ             | -0.4 ~ 1.975 | V    | 1,3   |
| Voltage on VPP supply relative to GND    | VPP              | -0.4 ~ 3.0   | V    | 4     |
| Operating temperature (Case, Commercial) | T <sub>opr</sub> | 0 ~ 95       | °C   | 1,5   |
| Operating temperature (Case, Industrial) | T <sub>opr</sub> | -40 ~ 95     | °C   | 1,5   |
| Storage temperature                      | T <sub>stg</sub> | -55 ~ +150   | °C   | 1,2   |

#### Notes:

- Permanent device damage may occur if 'ABSOLUTE MAXIMUM RATINGS' are exceeded. Functional operation should be restricted to recommended operating condition.  
Exposure to higher than recommended voltage for extended periods of time could affect device reliability. Stresses greater than those listed under "Absolute Maximum Ratings" may cause permanent damage to the device. This is a stress rating only and functional operation of the device at these or any other conditions above those indicated in the operational sections of this specification is not implied. Exposure to absolute maximum rating conditions for extended periods may affect reliability
- Storage Temperature is the case surface temperature on the center/top side of the DRAM. For the measurement conditions, please refer to JESD51-2 standard.
- VDD and VDDQ must be within 300 mV of each other at all times and VREFCA must be not greater than 0.6 x VDDQ, When VDD and VDDQ are less than 500 mV; VREF may be equal to or less than 300 mV
- VPP must be equal or greater than VDD/VDDQ at all times
- Refer to JEDEC JC451 specification
- Values based on Micron DRAM specification

### DRAM Component Operating Temperature Range

| Symbol            | Parameter                          | Rating   | Units | Note |
|-------------------|------------------------------------|----------|-------|------|
| T <sub>oper</sub> | Normal Operating Temperature Range | 0 to 85  | °C    | 1,2  |
|                   | Extended Temperature Range         | 85 to 95 | °C    | 1,3  |

#### Notes:

- Operating Temperature TOPER is the case surface temperature on the center / top side of the DRAM. For measurement conditions, please refer to the JEDEC document JE51-2.
- The Normal Temperature Range specifies the temperatures where all DRAM specifications will be supported. During operation, the DRAM case temperature must be maintained between 0 - 85°C under all operating conditions.
- Some applications require operation of the DRAM in the Extended Temperature Range between 85°C and 95°C case temperature. Full specifications are guaranteed in this range, but the following additional conditions apply:
  - Refresh commands must be doubled in frequency, therefore reducing the Refresh interval tREFI to 3.9 μs. It is also possible to specify a component with 1X refresh (tREFI to 7.8μs) in the Extended Temperature Range. Please refer to the DIMM SPD for option availability.
  - If Self-Refresh operation is required in the Extended Temperature Range, then it is mandatory to either use the Manual Self-Refresh mode with Extended Temperature Range capability (MR2 A6 = 0b and MR2 A7 = 1b) or enable the optional Auto Self-Refresh mode (MR2 A6 = 1b and MR2 A7 = 0b). DDR4 SDRAMs support Auto Self-Refresh and in Extended Temperature Range and please refer to component datasheet and/or the DIMM SPD for tREFI requirements in the Extended Temperature Range

### tREFI by Device Density

| Parameter                         | Symbol | 2Gb                             | 4Gb | 8Gb | 16Gb | Units |    |
|-----------------------------------|--------|---------------------------------|-----|-----|------|-------|----|
| Average periodic refresh interval | tREFI  | 0°C ≤ T <sub>case</sub> ≤ 85°C  | 7.8 | 7.8 | 7.8  | 7.8   | μs |
|                                   |        | 85°C ≤ T <sub>case</sub> ≤ 95°C | 3.9 | 3.9 | 3.9  | 3.9   | μs |

|                |                   |
|----------------|-------------------|
| Datasheet      | 5/11/2017         |
| PS9ZUxx72x8xxx | Viking Technology |
| Revision D     | Page 19 of 40     |

## AC & DC Operating Conditions

### DC OPERATING CONDITIONS AND CHARACTERISTICS (POD12)

| Symbol | Parameter   | Rating          |               |                 | Units | Notes |
|--------|---|-----------------|---------------|-----------------|-------|-------|
|        |   | Min             | Typ           | Max             |       |       |
| VDD    | Supply Voltage VDD:<br>PC4:1.2V±5%,                             | 1.14            | <b>1.2</b>    | 1.26            | v     | 1,2,3 |
| VDDQ   | Supply Voltage for Output.<br>Values in () are at 70% of<br>VDD | 1.14<br>(0.798) | 1.2<br>(0.84) | 1.26<br>(0.882) | v     | 1     |
| VPP    | 2.5V +10%, -5%  | 2.375           | 2.5           | 2.75            | v     | 3     |
| VDDSPD | @2.5V +10%  | 2.25            | 2.5           | 2.75            | v     |       |

**Notes:**

1. JESD8-24 specifies Vref to be 70% of VDDQ. Under all conditions VDDQ must be less than or equal to VDD.
2. VDDQ tracks with VDD. AC parameters are measured with VDD and VDDQ tied together.
3. DC bandwidth is limited to 20MHz.,
4. POD12 1.2 V Pseudo Open Drain Interface has a VDDQ value of 1.2V but the reference voltage allows POD12 to be used with other VDDQ values. POD12 signals have pull-up-only parallel input termination and have an asymmetric output drive impedance. For example, if the output drivers were using a 60 ohm pull-up drive impedance then the pull-down drivers would be expected to produce a 40 ohm pull-down drive impedance. POD12 does not explicitly call for series termination resistors, so it is suitable for point-to-point as well as multi-drop stub environments which may require some additional termination.

|                |                   |
|----------------|-------------------|
| Datasheet      | 5/11/2017         |
| PS9ZUxx72x8xxx | Viking Technology |
| Revision D     | Page 20 of 40     |

## DC CHARACTERISTICS, IDD CURRENTS

### IDD DEFINITIONS

| Symbol | Parameter   |
|--------|---|
| IDD0   | One bank ACTIVATE-PRECHARGE current                             |
| IPP0   | One bank ACTIVATE-PRECHARGE, Word Line Boost, IPP current       |
| IDD1   | One bank ACTIVATE-READ-PRECHARGE current                        |
| IDD2N  | Precharge standby current                                       |
| IDD2NT | Precharge standby ODT current                                   |
| IDD2P  | Precharge power-down current                                    |
| IDD2Q  | Precharge quiet standby current                                 |
| IDD3N  | Active standby current  |
| IPP3N  | Active standby IPP current                                      |
| IDD3P  | Active power-down current                                       |
| IDD4R  | Burst read current  |
| IDDQ4R | Burst read IDDQ current   |
| IDD4W  | Burst write current   |
| IDD5B  | Burst refresh current (1x REF)                                  |
| IPP5B  | Burst refresh IPP current (1 x REF)                             |
| IDD6N  | Self refresh current: Normal temperature range (0°C to +85°C)   |
| IDD6E  | Self refresh current: Extended temperature range (0°C to +95°C) |
| IDD6R  | Self refresh current: Reduced temperature range (0°C to +45°C)  |
| IDD6A  | Auto self refresh current (25°C)                                |
| IDD6A  | Auto self refresh current (45°C)                                |
| IDD6A  | Auto self refresh current (75°C)                                |
| IDD7   | Bank interleave read current                                    |
| IPP7   | Bank interleave read IPP current                                |
| IDD8   | Maximum power-down current                                      |

#### Notes:

- 1) DDR4 IDD and IDDQ specs include the same DDR3 IDD and IDDQ specs with these exceptions:
  - a. IDD2P0 and IDD2P1 are replaced with a single IDD2P. There's no longer any difference in power for the DLL because of better DLL power management inside the DRAM device without any benefit for using slow exit.
  - b. IDD6 is renamed IDD6N Self Refresh Current: Normal Temperature Range
  - c. IDD6ET is renamed IDD6E Self-Refresh Current: Extended Temperature Range
  - d. IDD6TC is renamed IDD6AAut0 Self-Refresh Current
  - e. IDD8 is redefined from (optional) RESET Low Current to IDD8 Maximum Power Down Current,
- 2) IDD values are an average (not peak) current drawn throughout the entire time that it takes to execute the set of conditions specified by JEDEC standards.
- 3) Consult with Viking for tools to help specify the Total Design Power (TDP)

|                |                   |
|----------------|-------------------|
| Datasheet      | 5/11/2017         |
| PS9ZUxx72x8xxx | Viking Technology |
| Revision D     | Page 21 of 40     |

### ***I<sub>DD6</sub>* Specification**

| <b>Symbol</b> | <b>Temperature Range</b> | <b>Value</b> | <b>Unit</b> | <b>Notes</b> |
|---------------|--------------------------|--------------|-------------|--------------|
| <i>IDD6N</i>  | 0 - 85 °C                | 22           | <i>mA</i>   | 3,4          |
| <i>IDD6E</i>  | 0 - 95 °C                | 33           | <i>mA</i>   | 4,5,6        |
| <i>IDD6R</i>  | 0 - 45°C                 | 10           | <i>mA</i>   | 4,6,9        |
| <i>IDD6A</i>  | 0 °C ~ Ta                | 9            | <i>mA</i>   | 4,6,7,8      |
|               | Tb ~ Ty                  | 10           | <i>mA</i>   | 4,6,7,8      |
|               | Tz ~ TOPERmax            | 16           | <i>mA</i>   | 4,6,7,8      |

**Notes:**

1. Some IDD currents are higher for x16 organization due to larger page-size architecture.
2. Max. values for IDD currents considering worst case conditions of process, temperature and voltage.
3. Applicable for MR2 settings A6=0 and A7=0.
4. Supplier data sheets include a max value for IDD6.
5. Applicable for MR2 settings A6=0 and A7=1. IDD6ET is only specified for devices which support the Extended Temperature Range feature.
6. Refer to the supplier data sheet for the value specification method (e.g. max, typical) for IDD6ET and IDD6TC
7. Applicable for MR2 settings A6=1 and A7=0. IDD6TC is only specified for devices which support the Auto Self Refresh feature.
8. The number of discrete temperature ranges supported and the associated Ta - Tz values are supplier/design specific. Temperature ranges are specified for all supported values of TOPER. Refer to supplier data sheet for more information.
9. Applicable for MR2 settings . IDD6R is verified by design and characterization, and may not be subject to production test.

|                |                   |
|----------------|-------------------|
| Datasheet      | 5/11/2017         |
| PS9ZUxx72x8xxx | Viking Technology |
| Revision D     | Page 22 of 40     |

### IDD/IPP CURRENTS, SINGLE RANK, 4Gbit

| Symbol       | DDR4-1866 | DDR4-2133 | DDR4-2400 | Units |
|--------------|-----------|-----------|-----------|-------|
| IDD0         | 522       | 540       | 576       | mA    |
| IPP0         | 36        | 36        | 36        | mA    |
| IDD1         | 567       | 585       | 612       | mA    |
| IDD2N        | 396       | 414       | 450       | mA    |
| IDD2NT       | 450       | 486       | 522       | mA    |
| IDD2P        | 270       | 270       | 288       | mA    |
| IDD2Q        | 351       | 351       | 369       | mA    |
| IDD3N        | 549       | 567       | 603       | mA    |
| IPP3N        | 27        | 27        | 27        | mA    |
| IDD3P        | 396       | 396       | 396       | mA    |
| IDD4R        | 1260      | 1350      | 1440      | mA    |
| IDDQ4R       | 288       | 324       | 360       | mA    |
| IDD4W        | 1404      | 1584      | 1764      | mA    |
| IDD5B        | 1710      | 1710      | 1728      | mA    |
| IPP5B        | 198       | 198       | 198       | mA    |
| IDD6N        | 180       | 180       | 180       | mA    |
| IDD6E        | 243       | 243       | 243       | mA    |
| IDD6R        | 90        | 90        | 90        | mA    |
| IDD6A (25°C) | 81        | 81        | 81        | mA    |
| IDD6A (45°C) | 90        | 90        | 90        | mA    |
| IDD6A (75°C) | 144       | 144       | 144       | mA    |
| IDD7         | 1440      | 1665      | 1890      | mA    |
| IPP7         | 90        | 108       | 126       | mA    |
| IDD8         | 162       | 162       | 162       | mA    |

**Notes:**

1. Users should refer to the DRAM supplier data sheet and/or the DIMM SPD to determine if DDR4 SDRAM devices support the following options or requirements referred to in this material.
2. Values as per Micron Datasheet Revision "A".

|                |                   |
|----------------|-------------------|
| Datasheet      | 5/11/2017         |
| PS9ZUxx72x8xxx | Viking Technology |
| Revision D     | Page 23 of 40     |

**IDD CURRENTS, SINGLE RANK, 8Gbit**

| Symbol       | DDR4-2133 | DDR4-2400 | Units |
|--------------|-----------|-----------|-------|
| IDD0         | 495       | 540       | mA    |
| IPP0         | 27        | 27        | mA    |
| IDD1         | 630       | 675       | mA    |
| IDD2N        | 405       | 450       | mA    |
| IDD2NT       | 495       | 540       | mA    |
| IDD2P        | 225       | 270       | mA    |
| IDD2Q        | 405       | 405       | mA    |
| IDD3N        | 495       | 495       | mA    |
| IPP3N        | 27        | 27        | mA    |
| IDD3P        | 315       | 360       | mA    |
| IDD4R        | 1350      | 1350      | mA    |
| IDDQ4R       | 540       | 585       | mA    |
| IDD4W        | 1350      | 1440      | mA    |
| IDD5B        | 2025      | 2025      | mA    |
| IPP5B        | 270       | 270       | mA    |
| IDD6N        | 270       | 270       | mA    |
| IDD6E        | 315       | 315       | mA    |
| IDD6R        | 225       | 225       | mA    |
| IDD6A (25°C) | 180       | 180       | mA    |
| IDD6A (45°C) | 225       | 225       | mA    |
| IDD6A (75°C) | 315       | 315       | mA    |
| IDD7         | 1800      | 1845      | mA    |
| IPP7         | 135       | 135       | mA    |
| IDD8         | 180       | 180       | mA    |

**Notes:**

1. Users should refer to the DRAM supplier data sheet and/or the DIMM SPD to determine if DDR4 SDRAM devices support the following options or requirements referred to in this material.
2. Values as per Micron Datasheet Revision "A".

|                |                   |
|----------------|-------------------|
| Datasheet      | 5/11/2017         |
| PS9ZUxx72x8xxx | Viking Technology |
| Revision D     | Page 24 of 40     |



### IDD CURRENTS, DUAL RANK, 8Gbit

| Symbol       | DDR4-2133 | DDR4-2400 | Units | Notes |
|--------------|-----------|-----------|-------|-------|
| IDD0         | 1153      | 1180      | mA    | 1     |
| IPP0         | 703       | 703       | mA    | 1     |
| IDD1         | 1288      | 1324      | mA    | 1     |
| IDD2N        | 906       | 924       | mA    | 2     |
| IDD2NT       | 756       | 810       | mA    | 1     |
| IDD2P        | 798       | 798       | mA    | 2     |
| IDD2Q        | 870       | 888       | mA    | 2     |
| IDD3N        | 1032      | 1041      | mA    | 2     |
| IPP3N        | 564       | 564       | mA    | 2     |
| IDD3P        | 792       | 792       | mA    | 2     |
| IDD4R        | 1765      | 1864      | mA    | 1     |
| IDDQ4R       | 594       | 648       | mA    | 1     |
| IDD4W        | 1594      | 1657      | mA    | 1     |
| IDD5B        | 2809      | 2845      | mA    | 1     |
| IPP5B        | 829       | 829       | mA    | 1     |
| IDD6N        | 360       | 360       | mA    | 2     |
| IDD6E        | 486       | 486       | mA    | 2     |
| IDD6R        | 180       | 180       | mA    | 2     |
| IDD6A (25°C) | 162       | 162       | mA    | 2     |
| IDD6A (45°C) | 180       | 180       | mA    | 2     |
| IDD6A (75°C) | 288       | 288       | mA    | 2     |
| IDD7         | 2368      | 2404      | mA    | 1     |
| IPP7         | 739       | 743.5     | mA    | 1     |
| IDD8         | 248       | 248       | mA    | 2     |

**Notes:**

1. One module rank in the active IDD/PP, the other rank in IDD2P/PP3N.
2. All ranks in this IDD/PP condition.
3. Users should refer to the DRAM supplier data sheet and/or the DIMM SPD to determine if DDR4 SDRAM devices support the following options or requirements referred to in this material.
4. Values as per K4A8G045WB B-die Datasheet Revision "1.11".

|                |                   |
|----------------|-------------------|
| Datasheet      | 5/11/2017         |
| PS9ZUxx72x8xxx | Viking Technology |
| Revision D     | Page 25 of 40     |

## Input/Output Capacitance

| Symbol                  | Parameter                                      | DDR4-1600, 1867, 2133 |      | DDR4-2400,2667 |      | DDR4-3200 |     | Units | Note         |
|-------------------------|--|-----------------------|------|----------------|------|-----------|-----|-------|--------------|
|                         |  | Min                   | Max  | Min            | Max  | Min       | Max |       |              |
| C <sub>IO</sub>         | Input/output capacitance                       | 0.7                   | 1.4  | 0.7            | 1.3  | TBD       | TBD | pF    | 1,2,3        |
| C <sub>DIO</sub>        | Input/output capacitance delta                 | -0.1                  | 0.1  | -0.1           | 0.1  | TBD       | TBD | pF    | 1,2,3,1<br>1 |
| C <sub>DDQS</sub>       | Input/output capacitance delta DQS and DQS#    |                       | 0.05 |                | 0.05 | TBD       | TBD | pF    | 1,2,3,5      |
| C <sub>CK</sub>         | Input capacitance, CK and CK#                  | 0.2                   | 0.8  | 0.2            | 0.7  | TBD       | TBD | pF    | 1,3          |
| C <sub>DCK</sub>        | Input capacitance delta CK and CK#             |                       | 0.05 |                | 0.05 | TBD       | TBD | pF    | 1,3,4        |
| C <sub>I</sub>          | Input capacitance(CTRL, ADD, CMD pins only)    | 0.2                   | 0.8  | 0.2            | 0.7  | TBD       | TBD | pF    | 1,3,6        |
| C <sub>DI_CTRL</sub>    | Input capacitance delta(All CTRL pins only)    | -0.1                  | 0.1  | -0.1           | 0.1  | TBD       | TBD | pF    | 1,3,7,8      |
| C <sub>DI_ADD_CMD</sub> | Input capacitance delta(All ADD/CMD pins only) | -0.1                  | 0.1  | -0.1           | 0.1  | TBD       | TBD | pF    | 1,2,9,<br>10 |
| C <sub>ALERT</sub>      | Input/output capacitance of ALERT              | 0.5                   | 1.5  | 0.5            | 1.5  | TBD       | TBD | pF    | 1,3          |
| C <sub>ZQ</sub>         | Input/output capacitance of ZQ                 | 0.5                   | 2.3  | 0.5            | 2.3  | TBD       | TBD | pF    | 1,3,12       |

### Notes:

1. This parameter is not subject to production test. It is verified by design and characterization. The silicon only capacitance is validated by de-embedding the package L & C parasitic. The capacitance is measured with VDD, VDDQ, VSS, VSSQ applied with all other signal pins floating. Measurement procedure.
2. DQ, DM, DQS\_T, DQS\_C, TDQS\_T, TDQS\_C. Although the DM, TDQS\_T and TDQS\_C pins have different functions, the loading matches DQ and DQS
3. This parameter applies to monolithic devices only; stacked/dual-die devices are not covered here.
4. Absolute value C<sub>K\_T-CK\_C</sub>
5. Absolute value of C<sub>IO(DQS\_T)</sub>-C<sub>IO(DQS\_C)</sub>
6. C<sub>I</sub> applies to ODT, CS\_n, CKE, A0-A17, BA0-BA1, BG0-BG1, RAS\_n, CAS\_n, WE\_n.
7. C<sub>DI\_CTRL</sub> applies to ODT, CS\_n and CKE
8. C<sub>DI\_CTRL</sub> = C<sub>I(CTRL)</sub>-0.5\*(C<sub>I(CLK\_T)</sub>+C<sub>I(CLK\_C)</sub>)
9. C<sub>DI\_ADD\_CMD</sub> applies to, A0-A17, BA0-BA1, BG0-BG1, RAS\_n, CAS\_n, WE\_n.
10. C<sub>DI\_ADD\_CMD</sub> = C<sub>I(ADD\_CMD)</sub>-0.5\*(C<sub>I(CLK\_T)</sub>+C<sub>I(CLK\_C)</sub>)
11. C<sub>DIO</sub> = C<sub>IO(DQ,DM)</sub>-0.5\*(C<sub>IO(DQS\_T)</sub>+C<sub>IO(DQS\_C)</sub>)
12. Maximum external load capacitance on ZQ pin: pF

|                |                   |
|----------------|-------------------|
| Datasheet      | 5/11/2017         |
| PS9ZUxx72x8xxx | Viking Technology |
| Revision D     | Page 26 of 40     |

## DC and AC Specifications for the SMBus Interface

The specifications for the SMBus follow JEDEC standards.

### Speed Bins by Speed Grade

#### DDR4-1600 Speed Bins and Operating Conditions

| Speed Bin   |         |                                    | DDR4-1600                                      |                 | Unit | NOTE  |               |
|---|---------|------------------------------------|--|-----------------|------|-------|---------------|
| CL-nRCD-nRP   |         |                                    | 11-11-11                                       |                 |      |       |               |
| Parameter   | Symbol  |                                    | Min  | Max             |      |       |               |
| Internal read command to first data                       | tAA     |                                    | 13.75 <sup>14</sup><br>(13.50) <sup>5,12</sup> | 18              | ns   |       |               |
| Internal read command to first data with read DBI enabled | tAA_DBI |                                    | tAA(min) + 2nCK                                | tAA(max) + 2nCK | ns   |       |               |
| ACT to internal read or write delay time                  | tRCD    |                                    | 13.75<br>(13.50) <sup>5,12</sup>               | -               | ns   |       |               |
| PRE command period  | tRP     |                                    | 13.75<br>(13.50) <sup>5,12</sup>               | -               | ns   |       |               |
| ACT to PRE command period                                 | tRAS    |                                    | 35   | 9 x tREFI       | ns   |       |               |
| ACT to ACT or REF command period                          | tRC     |                                    | 48.75<br>(48.50) <sup>5,12</sup>               | -               | ns   |       |               |
|   | Normal  | Read DBI                           |  |                 |      |       |               |
| CWL = 9   | CL = 9  | CL = 11<br>(Optional) <sup>5</sup> | tCK(AVG)                                       | Reserved        |      | ns    | 1,2,3,4,11,14 |
|   | CL = 10 | CL = 12                            | tCK(AVG)                                       | 1.5             | 1.6  | ns    | 1,2,3,4,11    |
| CWL = 9,11  | CL = 10 | CL = 12                            | tCK(AVG)                                       | Reserved        |      | ns    | 1,2,3,4       |
|   | CL = 11 | CL = 13                            | tCK(AVG)                                       | 1.25            | <1.5 | ns    | 1,2,3,4       |
|   | CL = 12 | CL = 14                            | tCK(AVG)                                       | 1.25            | <1.5 | ns    | 1,2,3         |
| Supported CL Settings                                     |         |                                    | (9),11,12                                      |                 | nCK  | 13,14 |               |
| Supported CL Settings with read DBI                       |         |                                    | (11),13,14                                     |                 | nCK  | 13    |               |
| Supported CWL Settings                                    |         |                                    | 9,11   |                 | nCK  |       |               |

### DDR4-1866 Speed Bins and Operating Conditions

| Speed Bin   |         |                               | DDR4-1866                                   |                            | Unit  | NOTE    |               |
|---|---------|-------------------------------|---|----------------------------|-------|---------|---------------|
| CL-nRCD-nRP   |         |                               | 13-13-13                                    |                            |       |         |               |
| Parameter   | Symbol  |                               | Min   | Max                        |       |         |               |
| Internal read command to first data                       | tAA     |                               | 13.92 <sup>14</sup> (13.50) <sup>5,12</sup> | 18                         | ns    |         |               |
| Internal read command to first data with read DBI enabled | tAA_DBI |                               | tAA(min) + 2nCK                             | tAA(max) + 2nCK            | ns    |         |               |
| ACT to internal read or write delay time                  | tRCD    |                               | 13.92 (13.50) <sup>5,12</sup>               | -                          | ns    |         |               |
| PRE command period  | tRP     |                               | 13.92 (13.50) <sup>5,12</sup>               | -                          | ns    |         |               |
| ACT to PRE command period                                 | tRAS    |                               | 34  | 9 x tREFI                  | ns    |         |               |
| ACT to ACT or REF command period                          | tRC     |                               | 47.92 (47.50) <sup>5,12</sup>               | -                          | ns    |         |               |
|   | Normal  | Read DBI                      |   |                            |       |         |               |
| CWL=9   | CL=9    | CL=11 (Optional) <sup>5</sup> | tCK(AVG)                                    | Reserved                   |       | ns      | 1,2,3,4,11,14 |
|   | CL=10   | CL=12                         | tCK(AVG)                                    | 1.5                        | 1.6   | ns      | 1,2,3,4,11    |
| CWL=9,11  | CL=10   | CL=12                         | tCK(AVG)                                    |                            |       |         | 4             |
|   | CL=11   | CL=13                         | tCK(AVG)                                    | 1.25                       | <1.5  | ns      | 1,2,3,4,6     |
|   |         |                               |   | (Optional) <sup>5,12</sup> |       |         |               |
| CL=12   | CL=14   | tCK(AVG)                      | 1.25  | <1.5                       | ns    | 1,2,3,6 |               |
| CWL=10,12   | CL=12   | CL=14                         | tCK(AVG)                                    | Reserved                   |       | ns      | 1,2,3,4       |
|   | CL=13   | CL=15                         | tCK(AVG)                                    | 1.071                      | <1.25 | ns      | 1,2,3,4       |
|   | CL=14   | CL=16                         | tCK(AVG)                                    | 1.071                      | <1.25 | ns      | 1,2,3         |
| Supported CL Settings                                     |         |                               | 9,11,12,13,14                               |                            | nCK   | 13,14   |               |
| Supported CL Settings with read DBI                       |         |                               | 11,13,14,15,16                              |                            | nCK   | 13      |               |
| Supported CWL Settings                                    |         |                               | 9,10,11,12                                  |                            | nCK   |         |               |

### DDR4-2133 Speed Bins and Operating Conditions

| Speed Bin   |         |   | DDR4-2133                  |                            | Unit   | NOTE          |           |
|---|---------|---|----------------------------|----------------------------|--------|---------------|-----------|
| CL-nRCD-nRP   |         |   | 15-15-15                   |                            |        |               |           |
| Parameter   | Symbol  | Min   | Max                        |                            |        |               |           |
| Internal read command to first data                       | tAA     | 14.06 <sup>14</sup> (13.75) <sup>5,12</sup> | 18                         |                            | ns     |               |           |
| Internal read command to first data with read DBI enabled | tAA_DBI | tAA(min) + 3nCK                             | tAA(max) + 3nCK            |                            | ns     |               |           |
| ACT to internal read or write delay time                  | tRCD    | 14.06 (13.75) <sup>5,12</sup>               | -                          |                            | ns     |               |           |
| PRE command period  | tRP     | 14.06 (13.75) <sup>5,12</sup>               | -                          |                            | ns     |               |           |
| ACT to PRE command period                                 | tRAS    | 33  | 9 x tREFI                  |                            | ns     |               |           |
| ACT to ACT or REF command period                          | tRC     | 47.06 (46.75) <sup>5,12</sup>               | -                          |                            | ns     |               |           |
|   |         |   |                            |                            |        |               |           |
|   | Normal  | Read DBI                                    |                            |                            | ns     | 1,2,3,4,11,14 |           |
| CWL = 9   | CL = 9  | CL = 11 (Optional) <sup>5</sup>             | tCK(AVG)                   | Reserved                   |        |               |           |
|   | CL = 10 | CL = 12                                     | tCK(AVG)                   | 1.5                        | 1.6    | ns            | 1,2,3,11  |
| CWL = 9,11  | CL = 11 | CL = 13                                     | tCK(AVG)                   |                            |        | ns            | 1,2,3,4,7 |
|   |         |   | tCK(AVG)                   | (Optional) <sup>5,12</sup> |        |               |           |
|   | CL = 12 | CL = 14                                     | tCK(AVG)                   | 1.25                       | <1.5   | ns            | 1,2,3,7   |
| CWL = 10,12   | CL = 13 | CL = 15                                     | tCK(AVG)                   | 1.071                      | <1.25  | ns            | 1,2,3,4,7 |
|   |         |   | tCK(AVG)                   | (Optional) <sup>5,12</sup> |        |               |           |
|   | CL = 14 | CL = 16                                     | tCK(AVG)                   | 1.071                      | <1.25  | ns            | 1,2,3,7   |
| CWL = 11,14   | CL = 14 | CL = TBD                                    | tCK(AVG)                   | Reserved                   |        | ns            | 1,2,3,4   |
|   | CL = 15 | CL = TBD                                    | tCK(AVG)                   | 0.938                      | <1.071 | ns            | 1,2,3,4   |
|   | CL = 16 | CL = TBD                                    | tCK(AVG)                   | 0.938                      | <1.071 | ns            | 1,2,3     |
| Supported CL Settings                                     |         |   | (9),(11),12,(13),14,15,16  |                            | nCK    | 13,14         |           |
| Supported CL Settings with read DBI                       |         |   | (11),(13),14,(15),16,18,19 |                            | nCK    |               |           |
| Supported CWL Settings                                    |         |   | 9,10,11,12,14              |                            | nCK    |               |           |

### DDR4-2400 Speed Bins and Operating Conditions

| Speed Bin   |         |                                 | DDR4-2400                                   |                            | Unit   | NOTE  |               |
|---|---------|---------------------------------|---|----------------------------|--------|-------|---------------|
| CL-nRCD-nRP   |         |                                 | 17-17-17                                    |                            |        |       |               |
| Parameter   | Symbol  |                                 | Min   | Max                        |        |       |               |
| Internal read command to first data                       | tAA     |                                 | 14.16 <sup>14</sup> (13.75) <sup>5,12</sup> | 18                         | ns     |       |               |
| Internal read command to first data with read DBI enabled | tAA_DBI |                                 | tAA(min) + 3nCK                             | tAA(max) + 3nCK            | ns     |       |               |
| ACT to internal read or write delay time                  | tRCD    |                                 | 14.16 (13.75) <sup>5,12</sup>               | -                          | ns     |       |               |
| PRE command period  | tRP     |                                 | 14.16 (13.75) <sup>5,12</sup>               | -                          | ns     |       |               |
| ACT to PRE command period                                 | tRAS    |                                 | 32  | 9 x tREFI                  | ns     |       |               |
| ACT to ACT or REF command period                          | tRC     |                                 | 46.16 (45.75) <sup>5,12</sup>               | -                          | ns     |       |               |
|   | Normal  | Read DBI                        |   |                            |        |       |               |
| CWL = 9   | CL = 9  | CL = 11 (Optional) <sup>5</sup> | tCK(AVG)                                    | Reserved                   |        | ns    | 1,2,3,4,11,14 |
|   | CL = 10 | CL = 12                         | tCK(AVG)                                    | 1.5                        | 1.6    | ns    | 1,2,3,11      |
| CWL = 9,11  | CL = 11 | CL = 13                         | tCK(AVG)                                    |                            |        | ns    | 1,2,3,4,7     |
|   |         |                                 | tCK(AVG)                                    | (Optional) <sup>5,12</sup> |        |       |               |
|   | CL = 12 | CL = 14                         | tCK(AVG)                                    | 1.25                       | <1.5   | ns    | 1,2,3,7       |
| CWL = 10,12   | CL = 13 | CL = 15                         | tCK(AVG)                                    | 1.071                      | <1.25  | ns    | 1,2,3,4,7     |
|   |         |                                 | tCK(AVG)                                    | (Optional) <sup>5,12</sup> |        |       |               |
|   | CL = 14 | CL = 16                         | tCK(AVG)                                    | 1.071                      | <1.25  | ns    | 1,2,3,7       |
| CWL = 11,14   | CL = 14 | CL = 17                         | tCK(AVG)                                    | Reserved                   |        | ns    | 1,2,3,4       |
|   | CL = 15 | CL = 18                         | tCK(AVG)                                    | 0.938                      | <1.071 | ns    | 1,2,3,4       |
|   | CL = 16 | CL = 19                         | tCK(AVG)                                    | 0.938                      | <1.071 | ns    | 1,2,3         |
| CWL = 12,16   | CL = 15 | CL = 18                         | tCK(AVG)                                    | Reserved                   |        | ns    | 1,2,3,4       |
|   | CL = 16 | CL = 19                         | tCK(AVG)                                    | Reserved                   |        | ns    | 1,2,3,4       |
|   | CL = 17 | CL = 20                         | tCK(AVG)                                    | 0.833                      | <0.938 | ns    | 1,2,3         |
|   | CL = 18 | CL = 21                         | tCK(AVG)                                    | 0.833                      | <0.938 | ns    | 1,2,3,4       |
| Supported CL Settings                                     |         |                                 | (10),(11),12,(13),14,15,16,17,18            |                            | nCK    | 13,14 |               |
| Supported CL Settings with read DBI                       |         |                                 | (12),(13),14,(15),16,18,19,20,21            |                            | nCK    |       |               |
| Supported CWL Settings                                    |         |                                 | 9,10,11,12,14,16                            |                            | nCK    |       |               |

|                |                   |
|----------------|-------------------|
| Datasheet      | 5/11/2017         |
| PS9ZUxx72x8xxx | Viking Technology |
| Revision D     | Page 30 of 40     |

## Timing Parameters by Speed Grade

| Speed  |                | DDR4-1600                      |                                | DDR4-1866                      |                                | DDR4-2133                      |                                | Units    | Note |  |
|--|----------------|--------------------------------|--------------------------------|--------------------------------|--------------------------------|--------------------------------|--------------------------------|----------|------|--|
| Parameter  | Symbol         | MIN                            | MAX                            | MIN                            | MAX                            | MIN                            | MAX                            |          |      |  |
| <b>Clock Timing</b>  |                |                                |                                |                                |                                |                                |                                |          |      |  |
| Minimum Clock Cycle Time (DLL off mode)  | tCK(DLL_OFF)   | 8                              | -                              | 8                              | -                              | 8                              | -                              | ns       | 23   |  |
| Average Clock Period   | tCK(avg)       | See Speed Bins Table           |                                |                                |                                |                                |                                |          | ps   |  |
| Average high pulse width   | tCH(avg)       | 0.48                           | 0.52                           | 0.48                           | 0.52                           | 0.48                           | 0.52                           | tCK(avg) |      |  |
| Average low pulse width  | tCL(avg)       | 0.48                           | 0.52                           | 0.48                           | 0.52                           | 0.48                           | 0.52                           | tCK(avg) |      |  |
| Absolute Clock Period  | tCK(abs)       | tCK(avg)min + tJIT(per)min_tot | tCK(avg)max + tJIT(per)max_tot | tCK(avg)min + tJIT(per)min_tot | tCK(avg)max + tJIT(per)max_tot | tCK(avg)min + tJIT(per)min_tot | tCK(avg)max + tJIT(per)max_tot | tCK      |      |  |
| Absolute clock HIGH pulse width  | tCH(abs)       | 0.45                           | -                              | 0.45                           | -                              | 0.45                           | -                              | tCK(avg) | 24   |  |
| Absolute clock Low pulse width   | tCL(abs)       | 0.45                           | -                              | 0.45                           | -                              | 0.45                           | -                              | tCK(avg) | 25   |  |
| Clock Period Jitter- total   | tJIT(per)_tot  | -0.1                           | 0.1                            | -0.1                           | 0.1                            | -0.1                           | 0.1                            | UI       | 26   |  |
| Clock Period Jitter- deterministic   | tJIT(per)_dj   | tbd                            |                                |                                |                                |                                |                                | UI       | 27   |  |
| Clock Period Jitter during DLL locking period                                  | tJIT(per, lck) | tbd                            |                                |                                |                                |                                |                                | UI       |      |  |
| Cycle to Cycle Period Jitter   | tJIT(cc)_tot   | 0.2                            |                                | 0.2                            |                                | 0.2                            |                                | UI       | 26   |  |
| Cycle to Cycle Period Jitter- deterministic                                    | tJIT(cc)_dj    | tbd                            |                                |                                |                                |                                |                                | UI       | 27   |  |
| Cycle to Cycle Period Jitter during DLL locking period                         | tJIT(cc, lck)  | tbd                            |                                |                                |                                |                                |                                | UI       |      |  |
| Duty cycle Jitter  | tJIT(duty)     | tbd                            |                                |                                |                                |                                |                                | UI       |      |  |
| Cumulative error across 2 cycles   | tERR(2per)     | tbd                            |                                |                                |                                |                                |                                | UI       |      |  |
| Cumulative error across 3 cycles   | tERR(3per)     | tbd                            |                                |                                |                                |                                |                                | UI       |      |  |
| Cumulative error across 4 cycles   | tERR(4per)     | tbd                            |                                |                                |                                |                                |                                | UI       |      |  |
| Cumulative error across 5 cycles   | tERR(5per)     | tbd                            |                                |                                |                                |                                |                                | UI       |      |  |
| Cumulative error across 6 cycles   | tERR(6per)     | tbd                            |                                |                                |                                |                                |                                | UI       |      |  |
| Cumulative error across 7 cycles   | tERR(7per)     | tbd                            |                                |                                |                                |                                |                                | UI       |      |  |
| Cumulative error across 8 cycles   | tERR(8per)     | tbd                            |                                |                                |                                |                                |                                | UI       |      |  |
| Cumulative error across 9 cycles   | tERR(9per)     | tbd                            |                                |                                |                                |                                |                                | UI       |      |  |
| Cumulative error across 10 cycles  | tERR(10per)    | tbd                            |                                |                                |                                |                                |                                | UI       |      |  |
| Cumulative error across 11 cycles  | tERR(11per)    | tbd                            |                                |                                |                                |                                |                                | UI       |      |  |
| Cumulative error across 12 cycles  | tERR(12per)    | tbd                            |                                |                                |                                |                                |                                | UI       |      |  |
| Cumulative error across n = 13, 14 ... 49, 50 cycles                           | tERR(nper)     | tbd                            |                                |                                |                                |                                |                                | UI       |      |  |
| <b>Command and Address Timing</b>  |                |                                |                                |                                |                                |                                |                                |          |      |  |
| CAS_n to CAS_n command delay for same bank group                               | tCCD_L         | 5                              | -                              | 5                              | -                              | 6                              | -                              | nCK      |      |  |
| CAS_n to CAS_n command delay for different bank group                          | tCCD_S         | 4                              | -                              | 4                              | -                              | 4                              | -                              | nCK      |      |  |
| ACTIVATE to ACTIVATE Command delay to different bank group for 2KB page size   | tRRD_S(2K)     | Max(4nCK,6ns)                  | -                              | Max(4nCK,5.3ns)                | -                              | Max(4nCK,5.3ns)                | -                              | nCK      |      |  |
| ACTIVATE to ACTIVATE Command delay to different bank group for 1KB page size   | tRRD_S(1K)     | Max(4nCK,5ns)                  | -                              | Max(4nCK,4.2ns)                | -                              | Max(4nCK,3.7ns)                | -                              | nCK      |      |  |
| ACTIVATE to ACTIVATE Command delay to different bank group for 1/2KB page size | tRRD_S(1/2K)   | Max(4nCK,5ns)                  | -                              | Max(4nCK,4.2ns)                | -                              | Max(4nCK,3.7ns)                | -                              | nCK      |      |  |
| ACTIVATE to ACTIVATE Command delay to same bank group for 2KB page size        | tRRD_L(2K)     | Max(4nCK,7.5ns)                | -                              | Max(4nCK,6.4ns)                | -                              | Max(4nCK,6.4ns)                | -                              | nCK      |      |  |
| ACTIVATE to ACTIVATE Command delay to same bank group for 1KB page size        | tRRD_L(1K)     | Max(4nCK,6ns)                  | -                              | Max(4nCK,5.3ns)                | -                              | Max(4nCK,5.3ns)                | -                              | nCK      |      |  |
| ACTIVATE to ACTIVATE Command delay to same bank group for 1/2KB page           | tRRD_L(1/2K)   | Max(4nCK,6ns)                  | -                              | Max(4nCK,5.3ns)                | -                              | Max(4nCK,5.3ns)                | -                              | nCK      |      |  |

|                |                   |
|----------------|-------------------|
| Datasheet      | 5/11/2017         |
| PS9ZUxx72x8xxx | Viking Technology |
| Revision D     | Page 31 of 40     |

| Speed  |               | DDR4-1600               |     | DDR4-1866               |     | DDR4-2133               |     | Units      | Note      |
|--|---------------|-------------------------|-----|-------------------------|-----|-------------------------|-----|------------|-----------|
| Parameter  | Symbol        | MIN                     | MAX | MIN                     | MAX | MIN                     | MAX |            |           |
| size   |               |                         |     |                         |     |                         |     |            |           |
| Four activate window for 2KB page size   | tFAW_2K       | 35                      |     | 30                      |     | 30                      |     | ns         |           |
| Four activate window for 1KB page size   | tFAW_1K       | 25                      |     | 23                      |     | 21                      |     | ns         |           |
| Four activate window for 1KB page size   | tFAW_1/2K     | 20                      |     | 17                      |     | 15                      |     | ns         |           |
| Delay from start of internal write transaction to internal read command for different bank group                               | tWTR_S        | max(2nCK,2.5ns)         | -   | max(2nCK,2.5ns)         | -   | max(2nCK,2.5ns)         | -   |            | 1,2,e     |
| Delay from start of internal write transaction to internal read command for same bank group                                    | tWTR_L        | max(4nCK,7.5ns)         | -   | max(4nCK,7.5ns)         | -   | max(4nCK,7.5ns)         | -   |            | 1         |
| Internal READ Command to PRECHARGE Command delay   | tRTP          | max(4nCK,7.5ns)         | -   | max(4nCK,7.5ns)         | -   | max(4nCK,7.5ns)         | -   |            |           |
| WRITE recovery time  | tWR           | 15                      | -   | 15                      | -   | 15                      | -   | ns         | 1         |
| WRITE recovery time when CRC and DM are enabled  | tWR_CRC_DM    | tWR+max(4nCK,3.75ns)    | -   | tWR+max(5nCK,3.75ns)    | -   | tWR+max(5nCK,3.75ns)    | -   | ns         | 1,29      |
| Delay from start of internal write transaction to internal read command for different bank groups with both CRC and DM enabled | tWTR_S_CRC_DM | tWTR_S+max(4nCK,3.75ns) | -   | tWTR_S+max(5nCK,3.75ns) | -   | tWTR_S+max(5nCK,3.75ns) | -   | ns         | 2,30      |
| Delay from start of internal write transaction to internal read command for same bank group with both CRC and DM enabled       | tWTR_L_CRC_DM | tWTR_L+max(4nCK,3.75ns) | -   | tWTR_L+max(5nCK,3.75ns) | -   | tWTR_L+max(5nCK,3.75ns) | -   | ns         | 3,31      |
| DLL locking time   | tDLLK         | TBD                     |     |                         |     |                         |     | nCK        |           |
| Mode Register Set command cycle time   | tMRD          | 8                       | -   | 8                       | -   | 8                       | -   | nCK        |           |
| Mode Register Set command update delay   | tMOD          | max(24nCK,15ns)         |     | max(24nCK,15ns)         |     | max(24nCK,15ns)         |     |            |           |
| Multi-Purpose Register Recovery Time   | tMPRR         | 1                       | -   | 1                       | -   | 1                       | -   | nCK        |           |
| Multi-Purpose Register Write Recovery Time   | tWR_MPR       | MIN = tMOD + AL + PL    | -   | MIN = tMOD + AL + PL    | -   | MIN = tMOD + AL + PL    | -   |            |           |
| <b>CS_n to Command Address Latency</b>   |               |                         |     |                         |     |                         |     |            |           |
| CS_n to Command Address Latency  | tCAL          | 3                       | -   | 4                       | -   | 4                       | -   | nCK        |           |
| <b>DRAM Data Timing</b>  |               |                         |     |                         |     |                         |     |            |           |
| DQS_t,DQS_c to DQ skew, per group, per access  | tDQSQ         | -                       | tbd | -                       | tbd | -                       | tbd | tCK(avg)/2 | 14,1,9    |
| DQS_t,DQS_c to DQ skew deterministic, per group, per access  | tDQSQ         | -                       | tbd | -                       | tbd | -                       | tbd | tCK(avg)/2 | 15,1,7,19 |
| DQ output hold time from DQS_t,DQS_c   | tQH           | tbd                     | -   | -                       | -   | -                       | -   | tCK(avg)/2 | 14,1,8,19 |
| DQ output hold time deterministic from DQS_t,DQS_c   | tQH           | tbd                     | -   | -                       | -   | -                       | -   | UI         | 15,1,7,19 |
| DQS_t,DQS_c to DQ Skew total, per group, per access; DBI enabled   | tDQSQ         | -                       | tbd | -                       | tbd | -                       | tbd | UI         | 14,20     |
| DQ output hold time total from DQS_t,DQS_c; DBI enabled  | tQH           | TBD                     | -   | TBD                     | -   | TBD                     | -   | UI         | 14,20     |
| DQ to DQ offset, per group, per access referenced to DQS_t,DQS_c   | tDQSQ         | TBD                     | TBD | TBD                     | TBD | TBD                     | TBD | UI         | 16,17     |
| <b>Data Strobe Timing</b>  |               |                         |     |                         |     |                         |     |            |           |
| DQS_t,DQS_c differential output high time  | tQSH          | TBD                     | TBD | TBD                     | TBD | TBD                     | TBD | tCK(avg)/2 | 22        |
| DQS_t,DQS_c differential output low time   | tQSL          | TBD                     | TBD | TBD                     | TBD | TBD                     | TBD | tCK(avg)/2 | 21        |
| <b>MPSM Timing</b>   |               |                         |     |                         |     |                         |     |            |           |
| Command path disable delay upon MPSM entry   | tMPED         | tMOD(min) + tCPDED(min) | -   | tMOD(min) + tCPDED(min) | -   | tMOD(min) + tCPDED(min) | -   |            |           |
| Valid clock requirement after MPSM entry   | tCKMPE        | tMOD(min) + tCPDED(min) | -   | tMOD(min) + tCPDED(min) | -   | tMOD(min) + tCPDED(min) | -   |            |           |
| Valid clock requirement before MPSM exit   | tCKMPX        | tCKSRX(min)             | -   | tCKSRX(min)             | -   | tCKSRX(min)             | -   |            |           |
| Exit MPSM to commands not requiring a locked DLL   | tXMP          | TBD                     | -   | TBD                     | -   | TBD                     | -   |            |           |
| Exit MPSM to commands requiring a locked DLL   | tXMPDLL       | tXMP(min) + tXSDLL(min) | -   | tXMP(min) + tXSDLL(min) | -   | tXMP(min) + tXSDLL(min) | -   |            |           |
| CS setup time to CKE   | tMPX_S        | TBD                     | -   | TBD                     | -   | TBD                     | -   |            |           |
| CS hold time to CKE  | tMPX_H        | TBD                     | -   | TBD                     | -   | TBD                     | -   |            |           |



| Speed   |                | DDR4-1600                   |         | DDR4-1866                   |         | DDR4-2133                   |         | Units | Note  |
|---|----------------|-----------------------------|---------|-----------------------------|---------|-----------------------------|---------|-------|-------|
| Parameter   | Symbol         | MIN                         | MAX     | MIN                         | MAX     | MIN                         | MAX     |       |       |
| <b>Calibration Timing</b>   |                |                             |         |                             |         |                             |         |       |       |
| Power-up and RESET calibration time   | tZQinit        | 1024                        | -       | 1024                        | -       | 1024                        | -       | nCK   |       |
| Normal operation Full calibration time  | tZQoper        | 512                         | -       | 512                         | -       | 512                         | -       | nCK   |       |
| Normal operation Short calibration time   | tZQCS          | 128                         | -       | 128                         | -       | 128                         | -       | nCK   |       |
| <b>Reset/Self Refresh Timing</b>  |                |                             |         |                             |         |                             |         |       |       |
| Exit Reset from CKE HIGH to a valid command   | tXPR           | max (5nCK,tRFC(min) + 10ns) | -       | max (5nCK,tRFC(min) + 10ns) | -       | max (5nCK,tRFC(min) + 10ns) | -       |       |       |
| Exit Self Refresh to commands not requiring a locked DLL  | tXS            | tRFC(min)+10ns              | -       | tRFC(min)+10ns              | -       | tRFC(min)+10ns              | -       |       |       |
| SRX to commands not requiring a locked DLL in Self Refresh ABORT  | tXS_ABORT(min) | tRFC4(min)+10ns             | -       | tRFC4(min)+10ns             | -       | tRFC4(min)+10ns             | -       |       |       |
| Exit Self Refresh to ZQCL,ZQCS and MRS (CL,CWL,WR,RTP and Gear Down)  | tXS_FAST (min) | tRFC4(min)+10ns             | -       | tRFC4(min)+10ns             | -       | tRFC4(min)+10ns             | -       |       |       |
| Exit Self Refresh to commands requiring a locked DLL  | tXSDLL         | tDLLK(min)                  | -       | tDLLK(min)                  | -       | tDLLK(min)                  | -       |       |       |
| Minimum CKE low width for Self refresh entry to exit timing   | tCKESR         | tCKE(min)+1nCK              | -       | tCKE(min)+1nCK              | -       | tCKE(min)+1nCK              | -       |       |       |
| Valid Clock Requirement after Self Refresh Entry (SRE) or Power-Down Entry (PDE)  | tCKSRE         | max(5nCK,10ns)              | -       | max(5nCK,10ns)              | -       | max(5nCK,10ns)              | -       |       |       |
| Valid Clock Requirement after Self Refresh Entry (SRE) or Power-Down when CA Parity is enabled                                    | tCKSRE_PAR     | max (5nCK,10ns)+PL          | -       | max (5nCK,10ns)+PL          | -       | max (5nCK,10ns)+PL          | -       |       |       |
| Valid Clock Requirement before Self Refresh Exit (SRX) or Power-Down Exit (PDX) or Reset Exit                                     | tCKSRX         | max(5nCK,10ns)              | -       | max(5nCK,10ns)              | -       | max(5nCK,10ns)              | -       |       |       |
| <b>Power Down Timing</b>  |                |                             |         |                             |         |                             |         |       |       |
| Exit Power Down with DLL on to any valid command; Exit Precharge Power Down with DLL frozen t commands not requiring a locked DLL | tXP            | max (4nCK,6ns)              | -       | max (4nCK,6ns)              | -       | max (4nCK,6ns)              | -       |       |       |
| Exit Precharge Power Down with DLL frozen to commands requiring a locked DLL  | tXPDLL         | max (10nCK, 24ns)           | -       | max (10nCK, 24ns)           | -       | max (10nCK, 24ns)           | -       |       | 3     |
| CKE minimum pulse width   | tCKE           | max (3nCK, 5ns)             | -       | max (3nCK, 5ns)             | -       | max (3nCK, 5ns)             | -       |       | 32,33 |
| Command pass disable delay  | tCPDED         | 4                           | -       | 4                           | -       | 4                           | -       |       |       |
| Power Down Entry to Exit Timing   | tPD            | tCKE(min)                   | 9*tREFI | tCKE(min)                   | 9*tREFI | tCKE(min)                   | 9*tREFI |       | 6     |
| Timing of ACT command to Power Down entry   | tACTPDEN       | 1                           | -       | 1                           | -       | 2                           | -       |       | 7     |
| Timing of PRE or PREA command to Power Down entry   | tPRPDEN        | 1                           | -       | 1                           | -       | 2                           | -       |       | 7     |
| Timing of RD/RDA command to Power Down entry  | tRDPDEN        | RL+4+1                      | -       | RL+4+1                      | -       | RL+4+1                      | -       | nCK   |       |
| Timing of WR command to Power Down entry (BL8OTF, BL8MRS, BC4OTF)   | tWRPDEN        | WL+4+(tWR/ tCK(avg))        | -       | WL+4+(tWR/ tCK(avg))        | -       | WL+4+(tWR/ tCK(avg))        | -       | nCK   | 4     |
| Timing of WRA command to Power Down entry (BL8OTF, BL8MRS, BC4OTF)  | tWRAPDEN       | WL+4+WR+1                   | -       | WL+4+WR+1                   | -       | WL+4+WR+1                   | -       | nCK   | 5     |
| Timing of WR command to Power Down entry (BC4MRS)   | tWRPBC4DEN     | WL+2+(tWR/ tCK(avg))        | -       | WL+2+(tWR/ tCK(avg))        | -       | WL+2+(tWR/ tCK(avg))        | -       | nCK   | 4     |
| Timing of WRA command to Power Down entry (BC4MRS)  | tWRAPBC4DEN    | WL+2+WR+1                   | -       | WL+2+WR+1                   | -       | WL+2+WR+1                   | -       | nCK   | 5     |
| Timing of REF command to Power Down entry   | tREFPDEN       | 1                           | -       | 1                           | -       | 2                           | -       | nCK   | 7,8   |
| Timing of MRS command to Power Down entry   | tMRSPDEN       | tMOD(min)                   | -       | tMOD(min)                   | -       | tMOD(min)                   | -       |       |       |
| <b>PDA Timing</b>   |                |                             |         |                             |         |                             |         |       |       |
| Mode Register Set command cycle time in PDA mode  | tMRD_PDA       | max(16nCK,10ns)             | -       | max(16nCK,10ns)             | -       | max(16nCK,10ns)             | -       |       |       |
| Mode Register Set command update delay in PDA mode  | tMOD_PDA       | tMOD                        |         | tMOD                        |         | tMOD                        |         |       |       |
| <b>ODT Timing</b>   |                |                             |         |                             |         |                             |         |       |       |

| Speed  |                | DDR4-1600                |        | DDR4-1866                |        | DDR4-2133                |        | Units    | Note |
|--|----------------|--------------------------|--------|--------------------------|--------|--------------------------|--------|----------|------|
| Parameter  | Symbol         | MIN                      | MAX    | MIN                      | MAX    | MIN                      | MAX    |          |      |
| Asynchronous RTT turn-on delay (Power-Down with DLL frozen)  | tAONAS         | 1                        | 9      | 1                        | 9      | 1                        | 9      | ns       |      |
| Asynchronous RTT turn-off delay (Power-Down with DLL frozen)   | tAOFAS         | 1                        | 9      | 1                        | 9      | 1                        | 9      | ns       |      |
| RTT dynamic change skew  | tADC           | 0.3                      | 0.7    | 0.3                      | 0.7    | 0.3                      | 0.7    | tCK(avg) |      |
| <b>Write Leveling Timing</b>   |                |                          |        |                          |        |                          |        |          |      |
| First DQS_t/DQS_n rising edge after write leveling mode is programmed  | tWLMRD         | 40                       | -      | 40                       | -      | 40                       | -      | nCK      | 13   |
| DQS_t/DQS_n delay after write leveling mode is programmed  | tWLDQSEN       | 25                       | -      | 25                       | -      | 25                       | -      | nCK      | 13   |
| Write leveling setup time from rising CK_t, CK_c crossing to rising DQS_t/DQS_n crossing   | tWLS           | 0.13                     | -      | 0.13                     | -      | 0.13                     | -      | tCK(avg) |      |
| Write leveling hold time from rising DQS_t/DQS_n crossing to rising CK_t, CK_c crossing  | tWLH           | 0.13                     | -      | 0.13                     | -      | 0.13                     | -      | tCK(avg) |      |
| Write leveling output delay  | tWLO           | 0                        | 9.5    | 0                        | 9.5    | 0                        | 9.5    | ns       |      |
| Write leveling output error  | tWLOE          |                          |        |                          |        |                          |        | ns       |      |
| <b>CA Parity Timing</b>  |                |                          |        |                          |        |                          |        |          |      |
| Commands not guaranteed to be executed during this time  | tPAR_UNKNOWN   | -                        | 4      | -                        | 4      | -                        | 4      |          |      |
| Delay from errant command to ALERT_n assertion   | tPAR_ALERT_ON  | -                        | PL+6ns | -                        | PL+6ns | -                        | PL+6ns |          |      |
| Pulse width of ALERT_n signal when asserted  | tPAR_ALERT_PW  | 48                       | 96     | 56                       | 112    | 64                       | 128    | nCK      |      |
| Time from when Alert is asserted till controller must start providing DES commands in Persistent CA parity mode  | tPAR_ALERT_RSP | -                        | 43     | -                        | 50     | -                        | 57     | nCK      |      |
| Parity Latency [ 1715.64, JC42.3C]   | PL             | 4                        |        | 4                        |        | 4                        |        | nCK      |      |
| <b>CRC Error Reporting</b>   |                |                          |        |                          |        |                          |        |          |      |
| CRC error to ALERT_n latency   | tCRC_ALERT     | 3                        | 13     | 3                        | 13     | 3                        | 13     | ns       |      |
| CRC ALERT_n pulse width  | tCRC_ALERT_PW  | 6                        | 10     | 6                        | 10     | 6                        | 10     | nCK      |      |
| Write recovery time when CRC and DM are enabled  | tWR_CRC_DM     | tWR+max (4nCK,3.75ns)    | -      | tWR+max (5nCK,3.75ns)    | -      | tWR+max (5nCK,3.75ns)    | -      | ns       | 10   |
| delay from start of internal write transaction to internal delay from start of internal write transaction to internal read command for different bank group with both CRC and DM enabled | tWTR_S_C RC_DM | tWTR_S+max (4nCK,3.75ns) | -      | tWTR_S+max (5nCK,3.75ns) | -      | tWTR_S+max (5nCK,3.75ns) | -      | ns       | 11   |
| delay from start of internal write transaction to internal delay from start of internal write transaction to internal read command for same bank group with both CRC and DM enabled      | tWTR_L_C RC_DM | tWTR_L+max (4nCK,3.75ns) | -      | tWTR_L+max (5nCK,3.75ns) | -      | tWTR_L+max (5nCK,3.75ns) | -      | ns       | 12   |
| <b>Geardown timing</b>   |                |                          |        |                          |        |                          |        |          |      |
| Exit RESET from CKE HIGH to a valid MRS geardown (T2/Reset)  | tXPR_GEAR      | TBD                      |        | TBD                      |        | TBD                      |        |          |      |
| CKE HIGH Assert Geardown Enable time(T2/CKE)   | tXS_GEAR       | TBD                      |        | TBD                      |        | TBD                      |        |          |      |
| MRS command to Sync pulse time(T3)   | tSYNC_GEAR     | TBD                      | TBD    | TBD                      | TBD    | TBD                      | TBD    |          |      |
| Sync pulse to First valid command(T4)  | tCMD_GEAR      | TBD                      |        | TBD                      |        | TBD                      |        |          |      |
| Geardown setup time  | tGEAR_setup    | TBD                      | TBD    | TBD                      | TBD    | TBD                      | TBD    |          |      |
| Geardown hold time   | tGEAR_hold     | TBD                      | TBD    | TBD                      | TBD    | TBD                      | TBD    |          |      |
| <b>tREFI</b>   |                |                          |        |                          |        |                          |        |          |      |
| tRFC1 (min)  | 2Gb            | 160                      | -      | 160                      | -      | 160                      | -      | ns       |      |
|  | 4Gb            | 260                      | -      | 260                      | -      | 260                      | -      | ns       |      |
|  | 8Gb            | 350                      | -      | 350                      | -      | 350                      | -      | ns       |      |
|  | 16Gb           | TBD by JEDEC board spec) | -      | TBD                      | -      | TBD                      | -      | ns       |      |
| tRFC2 (min)  | 2Gb            | 110                      | -      | 110                      | -      | 110                      | -      | ns       |      |
|  | 4Gb            | 160                      | -      | 160                      | -      | 160                      | -      | ns       |      |
|  | 8Gb            | 260                      | -      | 260                      | -      | 260                      | -      | ns       |      |
|  | 16Gb           | TBD by JEDEC board spec) | -      | TBD                      | -      | TBD                      | -      | ns       |      |
| tRFC4 (min)  | 2Gb            | 90                       | -      | 90                       | -      | 90                       | -      | ns       |      |

| Speed     |        | DDR4-1600                |     | DDR4-1866 |     | DDR4-2133 |     | Units | Note |
|-----------|--------|--------------------------|-----|-----------|-----|-----------|-----|-------|------|
| Parameter | Symbol | MIN                      | MAX | MIN       | MAX | MIN       | MAX |       |      |
|           | 4Gb    | 110                      | -   | 110       | -   | 110       | -   | ns    |      |
|           | 8Gb    | 160                      | -   | 160       | -   | 160       | -   | ns    |      |
|           | 16Gb   | TBD by JEDEC board spec) | -   | TBD       | -   | TBD       | -   | ns    |      |

## Timing Parameters by Speed Grade, continued

| Speed  |                | DDR4-2400                      |                                | DDR4-2667                      |                                | DDR4-3200                      |                                | Units    | Note |
|--|----------------|--------------------------------|--------------------------------|--------------------------------|--------------------------------|--------------------------------|--------------------------------|----------|------|
| Parameter  | Symbol         | MIN                            | MAX                            | MIN                            | MAX                            | MIN                            | MAX                            |          |      |
| <b>Clock Timing</b>  |                |                                |                                |                                |                                |                                |                                |          |      |
| Minimum Clock Cycle Time (DLL off mode)  | tCK(DLL_OFF)   | 8                              | -                              | 8                              | -                              | 8                              | -                              | ns       | 23   |
| Average Clock Period   | tCK(avg)       | See Speed Bins Table           |                                |                                |                                |                                |                                | ps       |      |
| Average high pulse width   | tCH(avg)       | 0.48                           | 0.52                           | 0.48                           | 0.52                           | 0.48                           | 0.52                           | tCK(avg) |      |
| Average low pulse width  | tCL(avg)       | 0.48                           | 0.52                           | 0.48                           | 0.52                           | 0.48                           | 0.52                           | tCK(avg) |      |
| Absolute Clock Period  | tCK(abs)       | tCK(avg)min + tJIT(per)min_tot | tCK(avg)max + tJIT(per)max_tot | tCK(avg)min + tJIT(per)min_tot | tCK(avg)max + tJIT(per)max_tot | tCK(avg)min + tJIT(per)min_tot | tCK(avg)max + tJIT(per)max_tot | tCK      |      |
| Absolute clock HIGH pulse width  | tCH(abs)       | 0.45                           | -                              | 0.45                           | -                              | 0.45                           | -                              | tCK(avg) | 24   |
| Absolute clock Low pulse width   | tCL(abs)       | 0.45                           | -                              | 0.45                           | -                              | 0.45                           | -                              | tCK(avg) | 25   |
| Clock Period Jitter- total   | JIT(per)_tot   | -42                            | 42                             | -0.1                           | 0.1                            | -0.1                           | 0.1                            | UI       | 26   |
| Clock Period Jitter- deterministic   | JIT(per)_dj    | tbd                            |                                |                                |                                |                                |                                | UI       | 27   |
| Clock Period Jitter during DLL locking period                                  | tJIT(per, lck) | tbd                            |                                |                                |                                |                                |                                | UI       |      |
| Cycle to Cycle Period Jitter   | tJIT(cc)_tot   | 83                             |                                | 0.2                            |                                | 0.2                            |                                | UI       | 26   |
| Cycle to Cycle Period Jitter- deterministic                                    | tJIT(cc)_dj    | tbd                            |                                |                                |                                |                                |                                | UI       | 27   |
| Cycle to Cycle Period Jitter during DLL locking period                         | tJIT(cc, lck)  | tbd                            |                                |                                |                                |                                |                                | UI       |      |
| Duty cycle Jitter  | tJIT(duty)     | tbd                            |                                |                                |                                |                                |                                | UI       |      |
| Cumulative error across 2 cycles   | tERR(2per)     | tbd                            |                                |                                |                                |                                |                                | UI       |      |
| Cumulative error across 3 cycles   | tERR(3per)     | tbd                            |                                |                                |                                |                                |                                | UI       |      |
| Cumulative error across 4 cycles   | tERR(4per)     | tbd                            |                                |                                |                                |                                |                                | UI       |      |
| Cumulative error across 5 cycles   | tERR(5per)     | tbd                            |                                |                                |                                |                                |                                | UI       |      |
| Cumulative error across 6 cycles   | tERR(6per)     | tbd                            |                                |                                |                                |                                |                                | UI       |      |
| Cumulative error across 7 cycles   | tERR(7per)     | tbd                            |                                |                                |                                |                                |                                | UI       |      |
| Cumulative error across 8 cycles   | tERR(8per)     | tbd                            |                                |                                |                                |                                |                                | UI       |      |
| Cumulative error across 9 cycles   | tERR(9per)     | tbd                            |                                |                                |                                |                                |                                | UI       |      |
| Cumulative error across 10 cycles  | tERR(10per)    | tbd                            |                                |                                |                                |                                |                                | UI       |      |
| Cumulative error across 11 cycles  | tERR(11per)    | tbd                            |                                |                                |                                |                                |                                | UI       |      |
| Cumulative error across 12 cycles  | tERR(12per)    | tbd                            |                                |                                |                                |                                |                                | UI       |      |
| Cumulative error across n = 13, 14 ... 49, 50 cycles                           | tERR(nper)     | tbd                            |                                |                                |                                |                                |                                | UI       |      |
| <b>Command and Address Timing</b>  |                |                                |                                |                                |                                |                                |                                |          |      |
| CAS_n to CAS_n command delay for same bank group                               | tCCD_L         | 6                              | -                              | tbd                            | -                              | -                              | -                              | nCK      |      |
| CAS_n to CAS_n command delay for different bank group                          | tCCD_S         | 4                              | -                              | 4                              | -                              | -                              | -                              | nCK      |      |
| ACTIVATE to ACTIVATE Command delay to different bank group for 2KB page size   | tRRD_S(2K)     | Max(4nCK, 5.3ns)               | -                              |                                | -                              | -                              | -                              | nCK      |      |
| ACTIVATE to ACTIVATE Command delay to different bank group for 1KB page size   | tRRD_S(1K)     | Max(4nCK, 3.3ns)               | -                              |                                | -                              | -                              | -                              | nCK      |      |
| ACTIVATE to ACTIVATE Command delay to different bank group for 1/2KB page size | tRRD_S(1/2K)   | Max(4nCK, 3.3ns)               | -                              |                                | -                              | -                              | -                              | nCK      |      |
| ACTIVATE to ACTIVATE Command delay to same bank group for 2KB page size        | tRRD_L(2K)     | Max(4nCK, 6.4ns)               | -                              |                                | -                              | -                              | -                              | nCK      |      |
| ACTIVATE to ACTIVATE Command delay to same bank group for 1KB page size        | tRRD_L(1K)     | Max(4nCK, 4.9ns)               | -                              |                                | -                              | -                              | -                              | nCK      |      |
| ACTIVATE to ACTIVATE Command delay to same bank group for 1/2KB page size      | tRRD_L(1/2K)   | Max(4nCK, 4.9ns)               | -                              |                                | -                              | -                              | -                              | nCK      |      |
| Four activate window for 2KB page size   | tFAW_2K        | 30                             |                                |                                |                                |                                |                                | ns       |      |

| Speed  |               | DDR4-2400               |     | DDR4-2667 |     | DDR4-3200 |     | Units      | Note      |
|--|---------------|-------------------------|-----|-----------|-----|-----------|-----|------------|-----------|
| Parameter  | Symbol        | MIN                     | MAX | MIN       | MAX | MIN       | MAX |            |           |
| Four activate window for 1KB page size   | tFAW_1K       | 21                      |     |           |     |           |     | ns         |           |
| Four activate window for 1KB page size   | tFAW_1/2K     | 13                      |     |           |     |           |     | ns         |           |
| Delay from start of internal write transaction to internal read command for different bank group                               | tWTR_S        | max(2nCK,2.5ns)         | -   |           | -   |           | -   |            | 1,2,e     |
| Delay from start of internal write transaction to internal read command for same bank group                                    | tWTR_L        | max(4nCK,7.5ns)         | -   |           | -   |           | -   |            | 1         |
| Internal READ Command to PRECHARGE Command delay   | tRTP          | max (4nCK,7.5ns)        | -   |           | -   |           | -   |            |           |
| WRITE recovery time  | tWR           | 15                      | -   |           | -   |           | -   | ns         | 1         |
| WRITE recovery time when CRC and DM are enabled  | tWR_CRC_DM    | tWR+max(5nCK,3.75ns)    | -   |           | -   |           | -   | ns         | 1,29      |
| Delay from start of internal write transaction to internal read command for different bank groups with both CRC and OM enabled | tWTR_S_CRC_DM | tWTR_S+max(5nCK,3.75ns) | -   |           | -   |           | -   | ns         | 2,30      |
| Delay from start of internal write transaction to internal read command for same bank group with both CRC and OM enabled       | tWTR_L_CRC_DM | tWTR_L+max(5nCK,3.75ns) | -   |           | -   |           | -   | ns         | 3,31      |
| DLL locking time   | tDLLK         | TBD                     |     |           |     |           |     | nCK        |           |
| Mode Register Set command cycle time   | tMRD          | 8                       | -   |           | -   |           | -   | nCK        |           |
| Mode Register Set command update delay   | tMOD          | max(24nCK,15ns)         | -   |           | -   |           | -   |            |           |
| Multi-Purpose Register Recovery Time   | tMPRR         | 1                       | -   |           | -   |           | -   | nCK        |           |
| Multi-Purpose Register Write Recovery Time   | tWR_MPR       | tMOD (min) + AL + PL    | -   |           | -   |           | -   |            |           |
| <b>CS_n to Command Address Latency</b>   |               |                         |     |           |     |           |     |            |           |
| CS_n to Command Address Latency  | tCAL          | 5                       | -   |           | -   |           | -   | nCK        |           |
| <b>DRAM Data Timing</b>  |               |                         |     |           |     |           |     |            |           |
| DQS_t,DQS_c to DQ skew, per group, per access  | tDQSQ         | -                       | tbd | -         | tbd | -         | tbd | tCK(avg)/2 | 14,1,9    |
| DQS_t,DQS_c to DQ skew deterministic, per group, per access  | tDQSQ         | -                       | tbd | -         | tbd | -         | tbd | tCK(avg)/2 | 15,1,7,19 |
| DQ output hold time from DQS_t,DQS_c   | tQH           | tbd                     | -   |           | -   |           | -   | tCK(avg)/2 | 14,1,8,19 |
| DQ output hold time deterministic from DQS_t, DQS_c  | tQH           | tbd                     | -   |           | -   |           | -   | UI         | 15,1,7,19 |
| DQS_t,DQS_c to DQ Skew total, per group, per access; DBI enabled   | tDQSQ         | -                       | tbd | -         | tbd | -         | tbd | UI         | 14,20     |
| DQ output hold time total from DQS_t, DQS_c; DBI enabled   | tQH           | TBD                     | -   | TBD       | -   | TBD       | -   | UI         | 14,20     |
| DQ to DQ offset , per group, per access refer-enced to DQS_t, DQS_c  | tDQSQ         | TBD                     | TBD | TBD       | TBD | TBD       | TBD | UI         | 16, 17    |
| <b>Data Strobe Timing</b>  |               |                         |     |           |     |           |     |            |           |
| DQS_t,DQS_c differential output high time  | tQSH          | TBD                     | TBD | TBD       | TBD | TBD       | TBD | tCK(avg)/2 | 22        |
| DQS_t,DQS_c differential output low time   | tQSL          | TBD                     | TBD | TBD       | TBD | TBD       | TBD | tCK(avg)/2 | 21        |
| <b>MPSM Timing</b>   |               |                         |     |           |     |           |     |            |           |
| Command path disable delay upon MPSM entry   | tMPED         | tMOD(min) + tCPDED(min) | -   |           |     |           | -   |            |           |
| Valid clock requirement after MPSM entry   | tCKMPE        | tMOD(min) + tCPDED(min) | -   |           |     |           | -   |            |           |
| Valid clock requirement before MPSM exit   | tCKMPX        | tCKSRX(min)             | -   |           |     |           | -   |            |           |
| Exit MPSM to commands not requiring a locked DLL   | tXMP          | TBD                     | -   |           |     |           | -   |            |           |
| Exit MPSM to commands requiring a locked DLL   | tXMPDLL       | tXMP(min) + tXSDDL(min) | -   |           |     |           | -   |            |           |
| CS setup time to CKE   | tMPX_S        | TBD                     | -   |           |     |           | -   |            |           |
| CS hold time to CKE  | tMPX_H        | TBD                     | -   |           |     |           | -   |            |           |
| <b>Calibration Timing</b>  |               |                         |     |           |     |           |     |            |           |
| Power-up and RESET calibration time  | tZQinit       | 1024                    | -   |           |     |           | -   | nCK        |           |
| Normal operation Full calibration time   | tZQoper       | 512                     | -   |           |     |           | -   | nCK        |           |

| Speed   |                | DDR4-2400                |         | DDR4-2667       |     | DDR4-3200       |         | Units    | Note  |
|---|----------------|--------------------------|---------|-----------------|-----|-----------------|---------|----------|-------|
| Parameter   | Symbol         | MIN                      | MAX     | MIN             | MAX | MIN             | MAX     |          |       |
| Normal operation Short calibration time   | tZQCS          | 128                      | -       |                 |     |                 | -       | nCK      |       |
| <b>Reset/Self Refresh Timing</b>  |                |                          |         |                 |     |                 |         |          |       |
| Exit Reset from CKE HIGH to a valid command   | tXPR           | max(5nCK,tRFC(min)+10ns) | -       |                 |     |                 | -       |          |       |
| Exit Self Refresh to commands not requiring a locked DLL  | tXS            | tRFC(min)+10ns           | -       |                 |     |                 | -       |          |       |
| SRX to commands not requiring a locked DLL in Self Refresh ABORT  | tXS_ABORT(min) | tRFC4(min)+10ns          | -       |                 |     |                 | -       |          |       |
| Exit Self Refresh to ZQCL,ZQCS and MRS (CL,CWL,WR,RTP and Gear Down)  | tXS_FAST (min) | tRFC4(min)+ 10ns         | -       |                 |     |                 | -       |          |       |
| Exit Self Refresh to commands requiring a locked DLL  | tXSDLL         | tDLL(min)                | -       |                 |     |                 | -       |          |       |
| Minimum CKE low width for Self refresh entry to exit timing   | tCKESR         | tCKE(min)+1nCK           | -       |                 |     |                 | -       |          |       |
| Valid Clock Requirement after Self Refresh Entry (SRE) or Power-Down Entry (PDE)  | tCKSRE         | max(5nCK,10ns)           | -       |                 |     |                 | -       |          |       |
| Valid Clock Requirement after Self Refresh Entry (SRE) or Power-Down when CA Parity is enabled                                    | tCKSRE_PAR     | max(5nCK,10ns)+PL        | -       |                 |     |                 | -       |          |       |
| Valid Clock Requirement before Self Refresh Exit (SRX) or Power-Down Exit (PDX) or Reset Exit                                     | tCKSRX         | max(5nCK,10ns)           | -       |                 |     |                 | -       |          |       |
| <b>Power Down Timing</b>  |                |                          |         |                 |     |                 |         |          |       |
| Exit Power Down with DLL on to any valid command; Exit Precharge Power Down with DLL frozen t commands not requiring a locked DLL | tXP            | max(4nCK,6ns)            | -       |                 |     |                 | -       |          |       |
| Exit Precharge Power Down with DLL frozen to commands requiring a locked DLL  | tXPDLL         | max(10nCK, 24ns)         | -       |                 |     |                 | -       |          | 3     |
| CKE minimum pulse width   | tCKE           | max(3nCK, 5ns)           | -       |                 |     |                 | -       |          | 32,33 |
| Command pass disable delay  | tCPDED         | 4                        | -       |                 |     |                 | -       |          |       |
| Power Down Entry to Exit Timing   | tPD            | tCKE(min)                | 9*tREFI |                 |     |                 | 9*tREFI |          | 6     |
| Timing of ACT command to Power Down entry   | tACTPDEN       | 2                        | -       |                 |     |                 | -       |          | 7     |
| Timing of PRE or PREA command to Power Down entry   | tPRPDEN        | 2                        | -       |                 |     |                 | -       |          | 7     |
| Timing of RD/RDA command to Power Down entry  | tRDPDEN        | RL+4+1                   | -       |                 |     |                 | -       | nCK      |       |
| Timing of WR command to Power Down entry (BL8OTF, BL8MRS, BC4OTF)   | tWRPDEN        | WL+4+(tWR/ tCK(avg))     | -       |                 |     |                 | -       | nCK      | 4     |
| Timing of WRA command to Power Down entry (BL8OTF, BL8MRS, BC4OTF)  | tWRAPDEN       | WL+4+WR+1                | -       |                 |     |                 | -       | nCK      | 5     |
| Timing of WR command to Power Downentry (BC4MRS)  | tWRPBC4DEN     | WL+2+(tWR/ tCK(avg))     | -       |                 |     |                 | -       | nCK      | 4     |
| Timing of WRA command to Power Down entry (BC4MRS)  | tWRAPBC4DEN    | WL+2+WR+1                | -       |                 |     |                 | -       | nCK      | 5     |
| Timing of REF command to Power Down entry   | tREFPDEN       | 2                        | -       |                 |     |                 | -       | nCK      | 7,8   |
| Timing of MRS command to Power Down entry   | tMRSPDEN       | tMOD(min)                | -       |                 |     |                 | -       |          |       |
| <b>PDA Timing</b>   |                |                          |         |                 |     |                 |         |          |       |
| Mode Register Set command cycle time in PDA mode  | tMRD_PDA       | max(16nCK,10ns)          | -       | max(16nCK,10ns) | -   | max(16nCK,10ns) | -       |          |       |
| Mode Register Set command update delay in PDA mode  | tMOD_PDA       | tMOD                     |         | tMOD            |     | tMOD            |         |          |       |
| <b>ODT Timing</b>   |                |                          |         |                 |     |                 |         |          |       |
| Asynchronous RTT turn-on delay (Power-Down with DLL frozen)   | tAONAS         | 1                        | 9       |                 |     |                 |         | ns       |       |
| Asynchronous RTT turn-off delay (Power-Down with DLL frozen)  | tAOFAS         | 1                        | 9       |                 |     |                 |         | ns       |       |
| RTT dynamic change skew   | tADC           | 0.3                      | 0.7     |                 |     |                 |         | tCK(avg) |       |
| <b>Write Leveling Timing</b>  |                |                          |         |                 |     |                 |         |          |       |
| First DQS_t/DQS_n rising edge after write leveling mode is programmed   | tWLMRD         | 40                       | -       |                 |     |                 |         | nCK      | 13    |
| DQS_t/DQS_n delay after write leveling mode is programmed   | tWLDQSEN       | 25                       | -       |                 |     |                 |         | nCK      | 13    |

| Speed  |                | DDR4-2400                |               | DDR4-2667      |     | DDR4-3200 |     | Units    | Note |
|--|----------------|--------------------------|---------------|----------------|-----|-----------|-----|----------|------|
| Parameter  | Symbol         | MIN                      | MAX           | MIN            | MAX | MIN       | MAX |          |      |
| Write leveling setup time from rising CK <sub>t</sub> , CK <sub>c</sub> crossing to rising DQS, t/DQS <sub>n</sub> crossing  | tWLS           | 0.13                     | -             |                |     |           |     | tCK(avg) |      |
| Write leveling hold time from rising DQS, t/DQS <sub>n</sub> crossing to rising CK <sub>t</sub> , CK <sub>c</sub> crossing   | tWLH           | 0.13                     | -             |                |     |           |     | tCK(avg) |      |
| Write leveling output delay  | tWLO           | 0                        | 9.5           |                |     |           |     | ns       |      |
| Write leveling output error  | tWLOE          |                          |               |                |     |           |     | ns       |      |
| <b>CA Parity Timing</b>  |                |                          |               |                |     |           |     |          |      |
| Commands not guaranteed to be executed during this time  | tPAR_UNKNOWN   | -                        | Max(2nCK,3ns) |                |     |           |     |          |      |
| Delay from errant command to ALERT <sub>n</sub> assertion  | tPAR_ALERT_ON  | -                        | PL+6ns        |                |     |           |     |          |      |
| Pulse width of ALERT <sub>n</sub> signal when asserted   | tPAR_ALERT_PW  | 72                       | 144           |                |     |           |     | nCK      |      |
| Time from when Alert is asserted till controller must start providing DES commands in Persistent CA parity mode  | tPAR_ALERT_RSP | -                        | 64            |                |     |           |     | nCK      |      |
| Parity Latency [ 1715.64, JC42.3C]   | PL             | 5                        |               |                |     |           |     | nCK      |      |
| <b>CRC Error Reporting</b>   |                |                          |               |                |     |           |     |          |      |
| CRC error to ALERT <sub>n</sub> latency  | tCRC_ALERT     | -                        | 13            |                |     |           |     | ns       |      |
| CRC ALERT <sub>n</sub> pulse width   | CRC_ALERT_PW   | 6                        | 10            |                |     |           |     | nCK      |      |
| Write recovery time when CRC and DM are enabled  | tWR_CRC_DM     | tWR+max (5nCK,3.75ns)    |               |                |     |           |     | ns       | 10   |
| delay from start of internal write transaction to internal delay from start of internal write transaction to internal read command for different bank group with both CRC and DM enabled | tWTR_S_C RC_DM | tWTR_S+max (5nCK,3.75ns) |               |                |     |           |     | ns       | 11   |
| delay from start of internal write transaction to internal delay from start of internal write transaction to internal read command for same bank group with both CRC and DM enabled      | tWTR_L_C RC_DM | tWTR_L+max (5nCK,3.75ns) |               |                |     |           |     | ns       | 12   |
| <b>Geardown timing</b>   |                |                          |               |                |     |           |     |          |      |
| Exit RESET from CKE HIGH to a valid MRS geardown (T2/Reset)  | tXPR_GEAR      | tXPR                     |               | tXPR           |     |           |     |          |      |
| CKE HIGH Assert Geardown Enable time(T2/CKE)   | tXS_GEAR       | tXS                      |               | tXS            |     |           |     |          |      |
| MRS command to Sync pulse time(T3)   | tSYNC_GEAR     | tMOD(min)+4nCK           |               | tMOD(min)+4nCK |     |           |     |          | 28   |
| Sync pulse to First valid command(T4)  | tCMD_GEAR      |                          |               | tMOD           |     | tMOD      |     |          | 28   |
| Geardown setup time  | tGEAR_setup    |                          |               | 2              | -   | 2         | -   | nCK      |      |
| Geardown hold time   | tGEAR_hold     |                          |               | 2              | -   | 2         | -   | nCK      |      |
| <b>tREFI</b>   |                |                          |               |                |     |           |     |          |      |
| tRFC1 (min)  | 2Gb            | 160                      | -             | 160            | -   | 160       | -   | ns       |      |
|  | 4Gb            | 260                      | -             | 260            | -   | 260       | -   | ns       |      |
|  | 8Gb            | 350                      | -             | 350            | -   | 350       | -   | ns       |      |
|  | 16Gb           | TBD by JEDEC board spec) | -             | TBD            | -   | TBD       | -   | ns       |      |
| tRFC2 (min)  | 2Gb            | 110                      | -             | 110            | -   | 110       | -   | ns       |      |
|  | 4Gb            | 160                      | -             | 160            | -   | 160       | -   | ns       |      |
|  | 8Gb            | 260                      | -             | 260            | -   | 260       | -   | ns       |      |
|  | 16Gb           | TBD by JEDEC board spec) | -             | TBD            | -   | TBD       | -   | ns       |      |
| tRFC4 (min)  | 2Gb            | 90                       | -             | 90             | -   | 90        | -   | ns       |      |
|  | 4Gb            | 110                      | -             | 110            | -   | 110       | -   | ns       |      |
|  | 8Gb            | 160                      | -             | 160            | -   | 160       | -   | ns       |      |
|  | 16Gb           | TBD by JEDEC board spec) | -             | TBD            | -   | TBD       | -   | ns       |      |

**Notes:**

- Start of internal write transaction is defined as follows:  
 For BL8 (Fixed by MRS and on-the-fly): Rising clock edge 4 clock cycles after WL.  
 For BC4 (on-the-fly): Rising clock edge 4 clock cycles after WL.  
 For BC4 (fixed by MRS): Rising clock edge 2 clock cycles after WL.
- A separate timing parameter will cover the delay from write to read when CRC and DM are simultaneously enabled
- Commands requiring a locked DLL are: READ (and RAP) and synchronous ODT commands.
- tWR is defined in ns, for calculation of tWRPDEN it is necessary to round up tWR/tCK to the next integer.
- WR in clock cycles as programmed in MR0.
- tREFI depends on TOPER.
- CKE is allowed to be registered low while operations such as row activation, precharge, autoprecharge or refresh are in progress, but power-down IDD spec will not be applied until finishing those operations.
- Although CKE is allowed to be registered LOW after a REFRESH command once tREFPDEN(min) is satisfied, there are cases where additional time such as tXPDLL(min) is also required. See 0.1.3 "Power-Down clarifications - Case 2" in RB11112 .

|                |                   |
|----------------|-------------------|
| Datasheet      | 5/11/2017         |
| PS9ZUxx72x8xxx | Viking Technology |
| Revision D     | Page 39 of 40     |

- DQ Receiver(Rx) compliance mask
- 9. For these parameters, the DDR4 SDRAM device supports  $t_{nPARAM}[nCK]=RU\{t_{PARAM}[ns]/t_{CK}(avg)[ns]\}$ , which is in clock cycles assuming all input clock jitter specifications are satisfied
- 10. When CRC and DM are both enabled,  $t_{WR\_CRC\_DM}$  is used in place of  $t_{WR}$ .
- 11. When CRC and DM are both enabled  $t_{WTR\_S\_CRC\_DM}$  is used in place of  $t_{WTR\_S}$ .
- 12. When CRC and DM are both enabled  $t_{WTR\_L\_CRC\_DM}$  is used in place of  $t_{WTR\_L}$ .
- 13. The max values are system dependent.
- 14. DQ to DQS total timing per group where the total includes the sum of deterministic and random timing terms for a specified BER. BER spec and measurement method are tbd.
- 15. The deterministic component of the total timing. Measurement method tbd.
- 16. DQ to DQ static offset relative to strobe per group. Measurement method tbd.
- 17. This parameter will be characterized and guaranteed by design.
- 18. When the device is operated with the input clock jitter, this parameter needs to be derated by the actual  $t_{jit}(per)_{total}$  of the input clock. (output Deratings are relative to the SDRAM input clock). Example tbd.
- 19. DRAM DBI mode is off.
- 20. DRAM DBI mode is enabled. Applicable to x8 and x16 DRAM only.
- 21.  $t_{QSL}$  describes the instantaneous differential output low pulse width on  $DQS\_t - DQS\_c$ , as measured from on falling edge to the next consecutive rising edge
- 22.  $t_{QSH}$  describes the instantaneous differential output high pulse width on  $DQS\_t - DQS\_c$ , as measured from on falling edge to the next consecutive rising edge
- 23. There is no maximum cycle time limit besides the need to satisfy the refresh interval  $t_{REFI}$
- 24.  $t_{CH}(abs)$  is the absolute instantaneous clock high pulse width, as measured from one rising edge to the following falling edge
- 25.  $t_{CL}(abs)$  is the absolute instantaneous clock low pulse width, as measured from one falling edge to the following rising edge
- 26. Total jitter includes the sum of deterministic and random jitter terms for a specified BER. BER target and measurement method are tbd.
- 27. The deterministic jitter component out of the total jitter. This parameter is characterized and guaranteed by design.
- 28. This parameter has to be even number of clocks
- 29. When CRC and DM are both enabled,  $t_{WR\_CRC\_DM}$  is used in place of  $t_{WR}$ .
- 30. When CRC and DM are both enabled  $t_{WTR\_S\_CRC\_DM}$  is used in place of  $t_{WTR\_S}$ .
- 31. When CRC and DM are both enabled  $t_{WTR\_L\_CRC\_DM}$  is used in place of  $t_{WTR\_L}$ .
- 32. After CKE is registered LOW, CKE signal level shall be maintained below  $V_{ILDC}$  for  $t_{CKE}$  specification ( Low pulse width).
- 33. After CKE is registered HIGH, CKE signal level shall be maintained above  $V_{IHDC}$  for  $t_{CKE}$  specification ( HIGH pulse width).  
 $UI=t_{CK}(avg).min/2$

|                |                   |
|----------------|-------------------|
| Datasheet      | 5/11/2017         |
| PS9ZUxx72x8xxx | Viking Technology |
| Revision D     | Page 40 of 40     |