

# DDR4 NON-ECC SOUDIMM VP9FUxx64x8xxx

The Viking DDR4 SOUDIMM memory module offers lower operating voltages, higher module densities and faster speed categories than the prior DDR3 generation. JEDEC DDR4 (JESD79-4) has been defined to provide higher performance, with improved reliability and reduced power, thereby representing a significant achievement relative to previous DRAM memory technologies.

Datasheet	5/11/2017
PS9FUxx64x8xxx_VP	Viking Technology
Revision B	Page 1 of 41

## REVISION HISTORY

Revision	Release Date	Description of Change	Checked By (Full Name)
A	9/23/15	Initial release from modified PS9FUxx64x8xxx_B. Change VRxxx to VPxxx. Update block diagram and 8gbit IDD values	
B	5/11/17	Revise logo and color scheme. Change company address. VPDSPD 2.2 to 3.6	

Datasheet	5/11/2017
PS9FUxx64x8xxx_VP	Viking Technology
Revision B	Page 2 of 41

## Legal Information

### Legal Information

Copyright© 2017 Sanmina Corporation. All rights reserved. The information in this document is proprietary and confidential to Sanmina Corporation. No part of this document may be reproduced in any form or by any means or used to make any derivative work (such as translation, transformation, or adaptation) without written permission from Sanmina. Sanmina reserves the right to revise this documentation and to make changes in content from time to time without obligation on the part of Sanmina to provide notification of such revision or change.

Sanmina provides this documentation without warranty, term or condition of any kind, either expressed or implied, including, but not limited to, expressed and implied warranties of merchantability, fitness for a particular purpose, and non-infringement. While the information contained herein is believed to be accurate, such information is preliminary, and should not be relied upon for accuracy or completeness, and no representations or warranties of accuracy or completeness are made. In no event will Sanmina be liable for damages arising directly or indirectly from any use of or reliance upon the information contained in this document. Sanmina may make improvements or changes in the product(s) and/or the program(s) described in this documentation at any time.

Sanmina, Viking Technology, Viking Modular Solutions, and the Viking logo are trademarks of Sanmina Corporation. Other company, product or service names mentioned herein may be trademarks or service marks of their respective owners.

### STATEMENT OF COMPLIANCE

Viking Technology, Sanmina Corporation ("Viking") shall use commercially reasonable efforts to provide components, parts, materials, products and processes to Customer that do not contain: (i) lead, mercury, hexavalent chromium, polybrominated biphenyls (PBB) and polybrominated diphenyl ethers (PBDE) above 0.1% by weight in homogeneous material or (ii) cadmium above 0.01% by weight of homogeneous material, except as provided in any exemption(s) from RoHS requirements (including the most current version of the "Annex" to Directive 2002/95/EC of 27 January, 2003), as codified in the specific laws of the EU member countries. Viking strives to obtain appropriate contractual protections from its suppliers in connection with the RoHS Directives.

All printed circuit boards (PCBs) have a flammability rating of UL94V-0.

Datasheet	5/11/2017
PS9FUxx64x8xxx_VP	Viking Technology
Revision B	Page 3 of 41

## 260 pin Ordering Information and Module Configuration

Viking Part Number	Voltage	Capacity	Module Configuration	Device Configuration	Device Package	Ranks	Speed	CAS Latency
VP9FU126428HBHyz	1.2V	4GB	512Mx64	512Mx8 (8)	4Gb FBGA	1	DDR4-17000	CL15 (15-15-15)
VP9FU126428HBJyz <sup>1</sup>	1.2V	4GB	512Mx64	512Mx8 (8)	4Gb FBGA	1	DDR4-19200	CL17 (17-17-17)
VP9FU1G6428HBHyz	1.2V	8GB	1Gx64	512Mx8 (16)	4Gb FBGA	2	DDR4-17000	CL15 (15-15-15)
VP9FU1G6428HBJyz <sup>1</sup>	1.2V	8GB	1Gx64	512Mx8 (16)	4Gb FBGA	2	DDR4-19200	CL17 (17-17-17)
VP9FU1G6428JBHyz <sup>1</sup>	1.2V	8GB	1Gx64	1024Mx8 (8)	8Gb FBGA	1	DDR4-17000	CL15 (15-15-15)
VP9FU1G6428JBJyz <sup>1</sup>	1.2V	8GB	1Gx64	1024Mx8 (8)	8Gb FBGA	1	DDR4-19200	CL17 (17-17-17)
VP9FU2G6428JBHyz <sup>1</sup>	1.2V	16GB	2Gx64	1024Mx8 (16)	8Gb FBGA	2	DDR4-17000	CL15 (15-15-15)
VP9FU2G6428JBJyz <sup>1</sup>	1.2V	16GB	2Gx64	1024Mx8 (16)	8Gb FBGA	2	DDR4-19200	CL17 (17-17-17)

**Notes:**

- For part numbers containing a lowercase x, contact Viking for the full PN.
- The lowercase letters y and z are wildcard characters that indicate DRAM vendor and die revisions and /or for customer specific locked BOMs. Refer to the Viking part number coversheet for details.

Datasheet	5/11/2017
PS9FUxx64x8xxx_VP	Viking Technology
Revision B	Page 4 of 41

## Features

- JEDEC Standard Power Supply
  - VDD = VDDQ = 1.2V± 5% (1.14V-1.26V)
  - External VPP = 2.5 Volt +10%, -5%
  - VDDSPD = 2.2 to 3.6 Volts
- 260 pin Small Outline Dual-In-Line Memory Module
- Edge finger connector ramp zone to reduce insertion force
- Point-to-Point topology to reduce loading
- Pseudo-open drain (POD12) DQ lines
- Internally generated VrefDQ
- On-chip CA Parity detection for the command/address bus
- Programmable CAS Latency: 13, 15,17
- Programmable CAS Write Latency (CWL).
- Programmable Additive Latency (Posted CAS)
- Per DRAM addressability is supported
- Data Bus Inversion support for x8 devices
- Selectable Fixed burst chop (BC4) of 4 and burst length (BL8) of 8 on-the-fly (OTF) via the mode register set (MRS)
- 8n prefetch with 2 or 4 selectable bank groups: 16 banks (4 bank groups x 4 banks per bank group)
- Separate activation, read, write, refresh operations for each bank group
- 7 mode registers
- Dynamic On-Die-Termination (ODT) and ODT Park for improved signal integrity.
- Self Refresh and several Power Down Modes
- DLL-off mode for power savings
- System Level Timing Calibration Support via Write Leveling and Multi Purpose Register (MPR) Read Pattern
- Serial Presence Detect with EEPROM
- Two On-DIMM Thermal Sensors
- Asynchronous Reset
- Bidirectional Differentially Buffered Data Strobes(DQS)
- SOUDIMM dimensions per JEDEC MO-310 maximum limits
- RoHS Compliant

## DDR4 SPEED BIN Nomenclature

Module Standard	SDRAM Standard	Clock
DDR4-14900	DDR4-1866	933 MHz
DDR4-17000	DDR4-2133	1066 MHz
DDR4-19200 <sup>1</sup>	DDR4-2400	1200 MHz
DDR4-21300 <sup>1</sup>	DDR4-2667	1333 MHz
DDR4-25600 <sup>1</sup>	DDR4-3200	1600 MHz

### Notes:

1. Contact Viking for availability date

## DDR4 Timing Summary

MT/s	tCK (ns)	CAS Latency (tCK)	tRCD (ns)	tRP (ns)	tRAS (ns)	tRC (ns)	CL-tRCD-tRP
<b>DDR4-1866</b>	1.071	13	13.92	13.92	34	47.92	13-13-13
<b>DDR4-2133</b>	0.93	15	14.06	14.06	33	47.05	15-15-15
<b>DDR4-2400</b>	0.83	17	14.16	14.16	32	46.16	17-17-17

### Notes:

- CL = CAS Latency, tRCD = Activate –to-Command Time, tRP = Precharge Time. Refer to Speed Bin tables for details.

Datasheet	5/11/2017
PS9FUxx64x8xxx_VP	Viking Technology
Revision B	Page 5 of 41

## Addressing

		4Gbit 512Mx8 DRAM	8Gbit 1024Mx8 DRAM
Bank Address	# of Bank Groups	4	4
	BG Address	BG0~BG1	BG0~BG1
	Bank Address in a BG	BA0~BA1	BA0~BA1
Row Address		A0~A14	64K:A0~A15
Column Address		A0~ A9	A0~ A9
Page size		512B	512B
Refresh Count		4K	8K

**Note:**

- Micron datasheet specified 512B / 1KB as page size with "Die revision dependant".
- In Hynix and Samsung Datasheet specifies 512B for x4 Device.

Datasheet	5/11/2017
PS9FUxx64x8xxx_VP	Viking Technology
Revision B	Page 6 of 41

## DDR4 260-pin SOUDIMM Pin Wiring Assignments/Configurations

Pin#	Symbol	Pin#	Symbol	Pin#	Symbol	Pin#	Symbol	Pin#	Symbol	Pin#	Symbol
1	VSS	45	DQ21	89	VSS	133	A1	177	DQS4_c	221	DQS6_t
2	VSS	46	DQ20	90	VSS	134	EVENT_n	178	DM4_n/DBI4_n	222	VSS
3	DQ5	47	VSS	91	CB1, NC	135	VDD	179	DQS4_t	223	VSS
4	DQ4	48	VSS	92	CB0, NC	136	VDD	180	VSS	224	DQ54
5	VSS	49	DQ17	93	VSS	137	CK0_t	181	VSS	225	DQ55
6	VSS	50	DQ16	94	VSS	138	CK1_t	182	DQ39	226	VSS
7	DQ1	51	VSS	95	DQS8_c	139	CK0_c	183	DQ38	227	VSS
8	DQ0	52	VSS	96	DM8_n, DBI8_n, NC	140	CK1_c	184	VSS	228	DQ50
9	VSS	53	DQS2_c	97	DQS8_t	141	VDD	185	VSS	229	DQ51
10	VSS	54	DM2_n/DBI2_n	98	VSS	142	VDD	186	DQ35	230	VSS
11	DQS0_c	55	DQS2_t	99	VSS	143	PARITY	187	DQ34	231	VSS
12	DM0_n/DBI0_n	56	VSS	100	CB6, NC	144	A0	188	VSS	232	DQ60
13	DQS0_t	57	VSS	101	CB2, NC	145	BA1	189	VSS	233	DQ61
14	VSS	58	DQ22	102	VSS	146	A10_AP	190	DQ45	234	VSS
15	VSS	59	DQ23	103	VSS	147	VDD	191	DQ44	235	VSS
16	DQ6	60	VSS	104	CB7, NC	148	VDD	192	VSS	236	DQ57
17	DQ7	61	VSS	105	CB3, NC	149	CS0_n	193	VSS	237	DQ56
18	VSS	62	DQ18	106	VSS	150	BA0	194	DQ41	238	VSS
19	VSS	63	DQ19	107	VSS	151	WE_n/A14	195	DQ40	239	VSS
20	DQ2	64	VSS	108	RESET_n	152	RAS_n/A16	196	VSS	240	DQS7_c
21	DQ3	65	VSS	109	CKE0	153	VDD	197	VSS	241	DM7_n, DBI7_n, NC
22	VSS	66	DQ28	110	CKE1	154	VDD	198	DQS5_c	242	DQS7_t
23	VSS	67	DQ29	111	VDD	155	ODT0	199	DM5_n/DBI5_n	243	VSS
24	DQ12	68	VSS	112	VDD	156	A15/CAS_n	200	DQS5_t	244	VSS
25	DQ13	69	VSS	113	BG1	157	CS1_n	201	VSS	245	DQ62
26	VSS	70	DQ24	114	ACT_n	158	A13	202	VSS	246	DQ63
27	VSS	71	DQ25	115	BG0	159	VDD	203	DQ46	247	VSS
28	DQ8	72	VSS	116	ALERT_n	160	VDD	204	DQ47	248	VSS
29	DQ9	73	VSS	117	VDD	161	ODT1	205	VSS	249	DQ58
30	VSS	74	DQS3_c	118	VDD	162	C0/CS2_n/NC	206	VSS	250	DQ59
31	VSS	75	DM3_n/DBI3_n	119	A12	163	VDD	207	DQ42	251	VSS
32	DQS1_c,	76	DQS3_t	120	A11	164	VREFCA	208	DQ43	252	VSS
33	DM1_n/DBI1_n	77	VSS	121	A9	165	C1/CS3_n/NC	209	VSS	253	SCL
34	DQS1_t	78	VSS	122	A7	166	SA2	210	VSS	254	SDA
35	VSS	79	DQ30	123	VDD	167	VSS	211	DQ52	255	VDDSPD
36	VSS	80	DQ31	124	VDD	168	VSS	212	DQ53	256	SA0
37	DQ15	81	VSS	125	A8	169	DQ37	213	VSS	257	VPP
38	DQ14	82	VSS	126	A5	170	DQ36	214	VSS	258	VTT
39	VSS	83	DQ26	127	A6	171	VSS	215	DQ49	259	VPP
40	VSS	84	DQ27	128	A4	172	VSS	216	DQ48	260	SA1
41	DQ10	85	VSS	129	VDD	173	DQ33	217	VSS		
42	DQ11	86	VSS	130	VDD	174	DQ32	218	VSS		
43	VSS	87	CB5, NC	131	A3	175	VSS	219	DQS6_c		
44	VSS	88	CB4, NC	132	A2	176	VSS	220	DM6_n, DBI6_n, NC		

### Notes:

- VPP is 2.5V DC
- A15 needed for 4GBit DRAM, A16 needed for 8GBit DRAM, A17 needed for 16GBit DRAM
- Only x8 and x16 DRAM support Data Mask (DM) and Data Bus Inversion (DBI). Only x8 DRAM support TDQS
- DM & DBI functions are supported with dedicated one pin labeled as DM\_n/DBI\_n
- The pin is bi-directional pin for DRAM. The DM\_n/DBI\_n pin is Active Low as DDR4 supports VDDQ reference termination.
- DM & DBI functions are programmable through DRAM Mode Register (MR). The MR bit location is bit A11 in MR1 and bit A12:A10 in MR5. Write operation: Either DM or DBI function can be enabled but both functions cannot be enabled simultaneously. When both DM and DBI functions are disabled, DRAM turns off its input receiver and does not expect any

Datasheet	5/11/2017
PS9FUxx64x8xxx_VP	Viking Technology
Revision B	Page 7 of 41

valid logic level. Read operation: Only DBI function applies. When DBI function is disabled, DRAM turns off its output driver and does not drive any valid logic level. DM & DBI functions are described in more detail on x8 based datasheets

## PIN FUNCTION DESCRIPTION

Pin Name	Description	Pin Name	Description
A0-A17'	Register address input	SCL	I2C serial bus clock for SPD/TS and register
BA0, BA1	Register bank select input	SDA	I2C serial bus data line for SPD/TS and register
BG0, BG1	Register bank group select input	SA0-SA2	I2C slave address select for SPD/TS and register
RAS_n <sup>2</sup>	Register row address strobe input	PAR	Register parity input
CAS_n <sup>3</sup>	Register column address strobe input	VDD	SDRAM core power supply
WE_n <sup>4</sup>	Register write enable input		
CS0_n, CS1_n, CS2_n, CS3_n	DIMM Rank Select Lines input		
CKE0, CKE1	Register clock enable lines input	VREFCA	SDRAM command/address reference supply
ODT0, ODT1	Register on-die termination control lines input	VSS	Power supply return (ground)
ACT_n	Register input for activate input	VDDSPD	Serial SPD/TS positive power supply
DQ0-DQ63	DIMM memory data bus	ALERT_n	Register ALERT_n output
CB0-CB7	DIMM ECC check bits	Vpp	DRAM Activation Power Supply
TDQS9_t-TDQS17_t	Data Buffer data strobes (positive line of differential pair)		
TDQS9_c- TDQS17_c	Data Buffer data strobes (negative line of differential pair)	RESET_n	Set Register and SDRAMs to a Known state
		EVENT_n	SPD signals a thermal event has occurred.
CK0_t, CK1_t	Register clock input (positive line of differential pair)	Vtt	SDRAM I/O termination supply
CK0_c, CK1_c	Register clocks input (negative line of differential pair)	RFU	Reserved for future use

### Notes:

1. Address A17 is only valid for 16GBit DRAM
2. RAS\_n is a multiplexed function with A16. (A16 needed for 8GBit DRAM)
3. CAS\_n is a multiplexed function with A15. (A15 needed for 4GBit DRAM)
4. WE\_n is a multiplexed function with A14

Datasheet	5/11/2017
PS9FUxx64x8xxx_VP	Viking Technology
Revision B	Page 8 of 41



## Input/Output Functional Descriptions

Symbol	Type	Function
CK_t, CK_c	Input	Clock: CK_t and CK_c are differential clock inputs. All address and control input signals are sampled on the crossing of the positive edge of CK_t and negative edge of CK_c.
CKE0, (CKE1)	Input	Clock Enable: CKE HIGH activates, and CKE Low deactivates, internal clock signals and device input buffers and output drivers. Taking CKE Low provides Precharge Power-Down and Self-Refresh operation (all banks idle), or Active Power-Down (row Active in any bank). CKE is asynchronous for Self-Refresh exit. After VREFCA and VREFDQ have become stable during the power on and initialization sequence, they must be maintained during all operations (including Self-Refresh). CKE must be maintained high throughout read and write accesses. Input buffers, excluding CK, CK_c, ODT and CKE, are disabled during power-down. Input buffers, excluding CKE, are disabled during Self-Refresh.
CS0_n, (CS1_n)	Input	Chip Select: All commands are masked when CS_n is registered HIGH. CS_n provides for external Rank selection on systems with multiple Ranks. CS_n is considered part of the command code.
C0,C1,C2	Input	Chip ID: Chip ID is only used for 3DS for 2,4,8high stack via TSV to select each slice of stacked component. Chip ID is considered part of the command code.
ODT0, (ODT1)	Input	On Die Termination: ODT (registered HIGH) enables termination resistance internal to the DDR4 SDRAM. When enabled, ODT is only applied to each DQ, DQS_t, DQS_c and DM_n/DBI_n/TDQS_t,NU/TDQS_c (When TDQS is enabled via Mode Register A11=1 in MR1) signal for x8 configurations. For x16 configuration ODT is applied to each DQ, DQSU_c, DQSU_t, DQSL_t, DQSL_c, DMU_n, and DML_n signal. The ODT pin will be ignored if MR1 is programmed to disable RTT_NOM.
ACT_n	Input	Activation Command Input: ACT_n defines the Activation command being entered along with CS_n. The input into RAS_n/A16, CAS_n/A15 and WE_n/A14 will be considered as Row Address A16, A15 and A14.
RAS_n/A16, CAS_n/A15, WE_n/A14	Input	Command Inputs RAS_n/A16, CAS_n/A15 and WE_n/A14 (along with CS_n) define the command being entered. Those pins have multi function. For example, for activation with ACT_n Low, those are Addressing like A16,A15 and A14 but for non-activation command with ACT_n High, those are Command pins for Read, Write and other command defined in command truth table.
DM_n/DBI_n/ TDQS_t, (DMU_n/DBIU_n), (DML_n/DBIL_n)	Input/ Output	Input Data Mask and Data Bus Inversion: DM_n is an input mask signal for write data. Input data is masked when DM_n is sampled LOW coincident with that input data during a Write access. DM_n is sampled on both edges of DQS. DM is muxed with DBI function by Mode Register A10,A11,A12 setting in MR5. For x8 device, the function of DM or TDQS is enabled by Mode Register A11 setting in MR1. DBI_n is an input/output identifying whether to store/output the true or inverted data. If DBI_n is LOW, the data will be stored/output after inversion inside the DDR4 SDRAM and not inverted if DBI_n is HIGH. TDQS is only supported in x8.
BG0 - BG1	Input	Bank Group Inputs: BG0 - BG1 define to which bank group an Active, Read, Write or Precharge command is being applied. BG0 also determines which mode register is to be accessed during a MRS cycle. x4/8 have BG0 and BG1 but x16 has only BG0.

Datasheet	5/11/2017
PS9FUxx64x8xxx_VP	Viking Technology
Revision B	Page 9 of 41

## Input/Output Functional Descriptions (cont.)

Symbol	Type	Function
BA0 - BA1	Input	Bank Address Inputs: BA0 - BA1 define to which bank an Active, Read, Write or Precharge command is being applied. Bank address also determines if the mode register or extended mode register is to be accessed during a MRS cycle.
A0 - A17	Input	Address Inputs: Provided the row address for ACTIVATE Commands and the column address for Read/Write commands to select one location out of the memory array in the respective bank. (A10/AP, A12/BC_n, RAS_n/A16, CAS_n/A15 and WE_n/A14 have additional functions, see other rows. The address inputs also provide the op-code during Mode Register Set commands. A17 is only defined for the x4 configuration.
A10 / AP	Input	Auto-precharge: A10 is sampled during Read/Write commands to determine whether Autoprecharge should be performed to the accessed bank after the Read/Write operation. (HIGH: Autoprecharge; LOW: no Autoprecharge). A10 is sampled during a Precharge command to determine whether the Precharge applies to one bank (A10 LOW) or all banks (A10 HIGH). If only one bank is to be precharged, the bank is selected by bank addresses.
A12 / BC_n	Input	Burst Chop: A12 / BC_n is sampled during Read and Write commands to determine if burst chop (on-the-fly) will be performed. (HIGH, no burst chop; LOW: burst chopped). See command truth table for details.
RESET_n	Input	Active Low Asynchronous Reset: Reset is active when RESET_n is LOW, and inactive when RESET_n is HIGH. RESET_n must be HIGH during normal operation. RESET_n is a CMOS rail to rail signal with DC high and low at 80% and 20% of VDD.
DQ	Input / Output	Data Input/ Output: Bi-directional data bus. If CRC is enabled via Mode register then CRC code is added at the end of Data Burst. Any DQ from DQ0~DQ3 may indicate the internal Vref level during test via Mode Register Setting MR4 A4=High. Refer to vendor specific datasheets to determine which DQ is used.
DQS_t, DQS_c, DQSU_t, DQSU_c, DQSL_t, DQSL_c	Input / Output	Data Strobe: output with read data, input with write data. Edge-aligned with read data, centered in write data. For x16, DQSL corresponds to the data on DQL0-DQL7; DQSU corresponds to the data on DQU0-DQU7. The data strobe DQS_t, DQSL_t, and DQSU_t are paired with differential signals DQS_c, DQSL_c, and DQSU_c, respectively, to provide differential pair signaling to the system during reads and writes. DDR4 SDRAM supports differential data strobe only and does not support single-ended.

Datasheet	5/11/2017
PS9FUxx64x8xxx_VP	Viking Technology
Revision B	Page 10 of 41

### Input/Output Functional Descriptions (cont.)

Symbol	Type	Function
ALERT_n	Output	Alert: It has multi functions such as CRC error flag, Command and Address Parity error flag. If there is error in CRC, then Alert_n goes LOW for the period time interval and goes back HIGH. IF there is error in Command Address Parity Check, then Alert_n goes LOW for relatively long period until on going DRAM internal recovery transaction to complete.
TEN	Input	Boundary Scan Mode Enable: Required on x16 devices and optional input on x4/x8 with densities equal to or greater than 8Gb. HIGH in this pin will enable boundary scan operation along with other pins. It is a CMOS rail to rail signal with DC high and low at 80% and 20% of VDD.
NC		No Connect: No internal electrical connection is present.
VDDQ	Supply	DQ Power Supply: 1.2 V +/- 0.06 V
VSSQ	Supply	DQ Ground
VDD	Supply	Power Supply: 1.2 V +/- 0.06 V
VSS	Supply	Ground
Vpp	Supply	DRAM Activation Power Supply: 2.5V (2.375V min , 2.75 max)
VREFCA	Supply	Reference voltage for CA
ZQ	Supply	Reference Pin for ZQ calibration

**Note:**

The input only pins (BG0-BG-1, BA0-BA1, A0-A17, ACT\_n, RAS\_n/A16, CAS\_n/A15, WE\_n/A14, CS\_n, CKE, ODT, and RESET\_n) do not supply termination.

Datasheet	5/11/2017
PS9FUxx64x8xxx_VP	Viking Technology
Revision B	Page 11 of 41

## MECHANICAL OUTLINE

PHYSICAL LAYOUT, SINGLE RANK, 260 pin

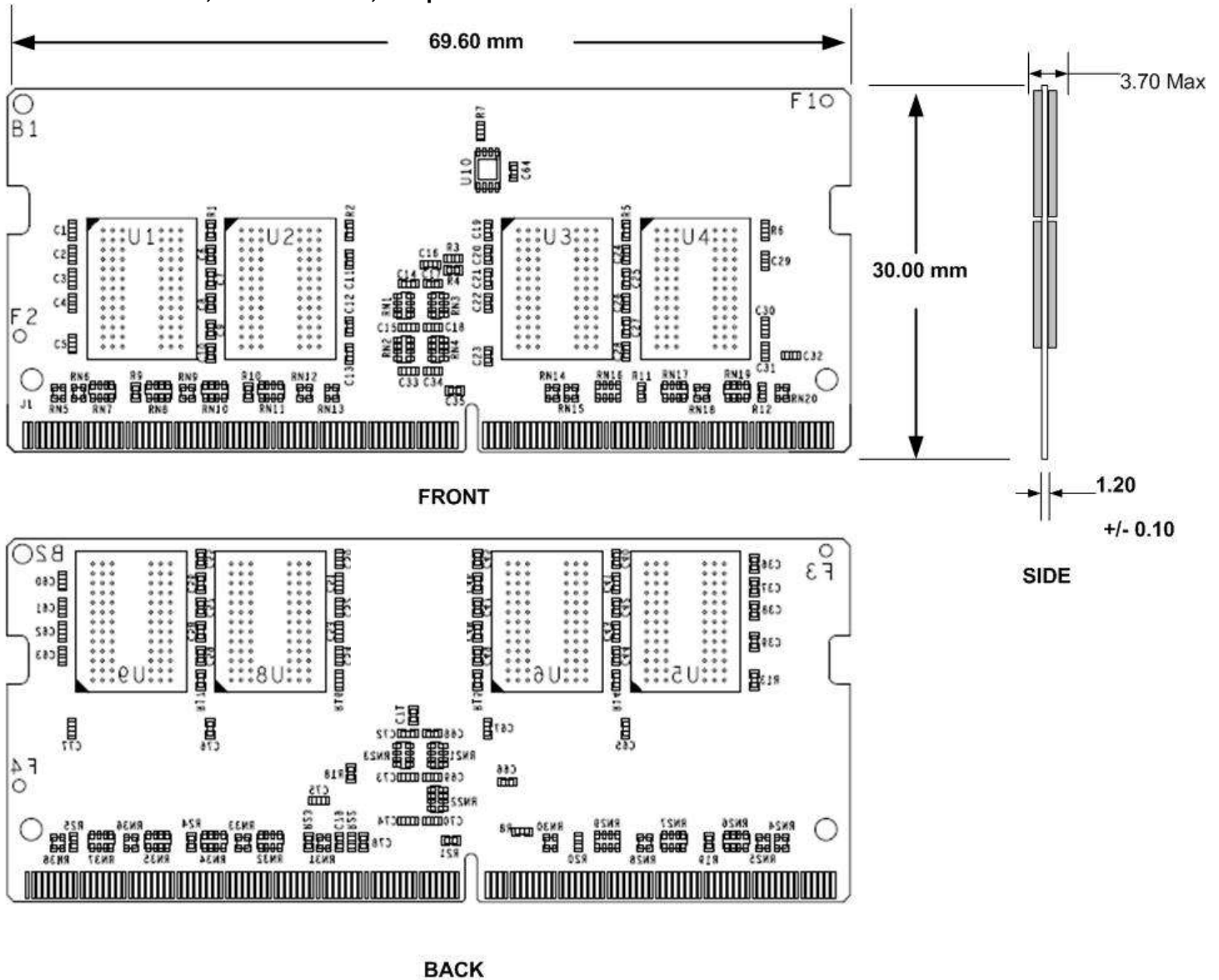

**Notes:**

- All dimensions in mm (inches)
- Tolerance is +/- 0.0127, unless otherwise stated
- Refer to JEDEC Standard Mechanical Outline MO-310 for other details

Datasheet	5/11/2017
PS9FUxx64x8xxx_VP	Viking Technology
Revision B	Page 12 of 41

**PHYSICAL LAYOUT, DUAL RANK, 260 pin**

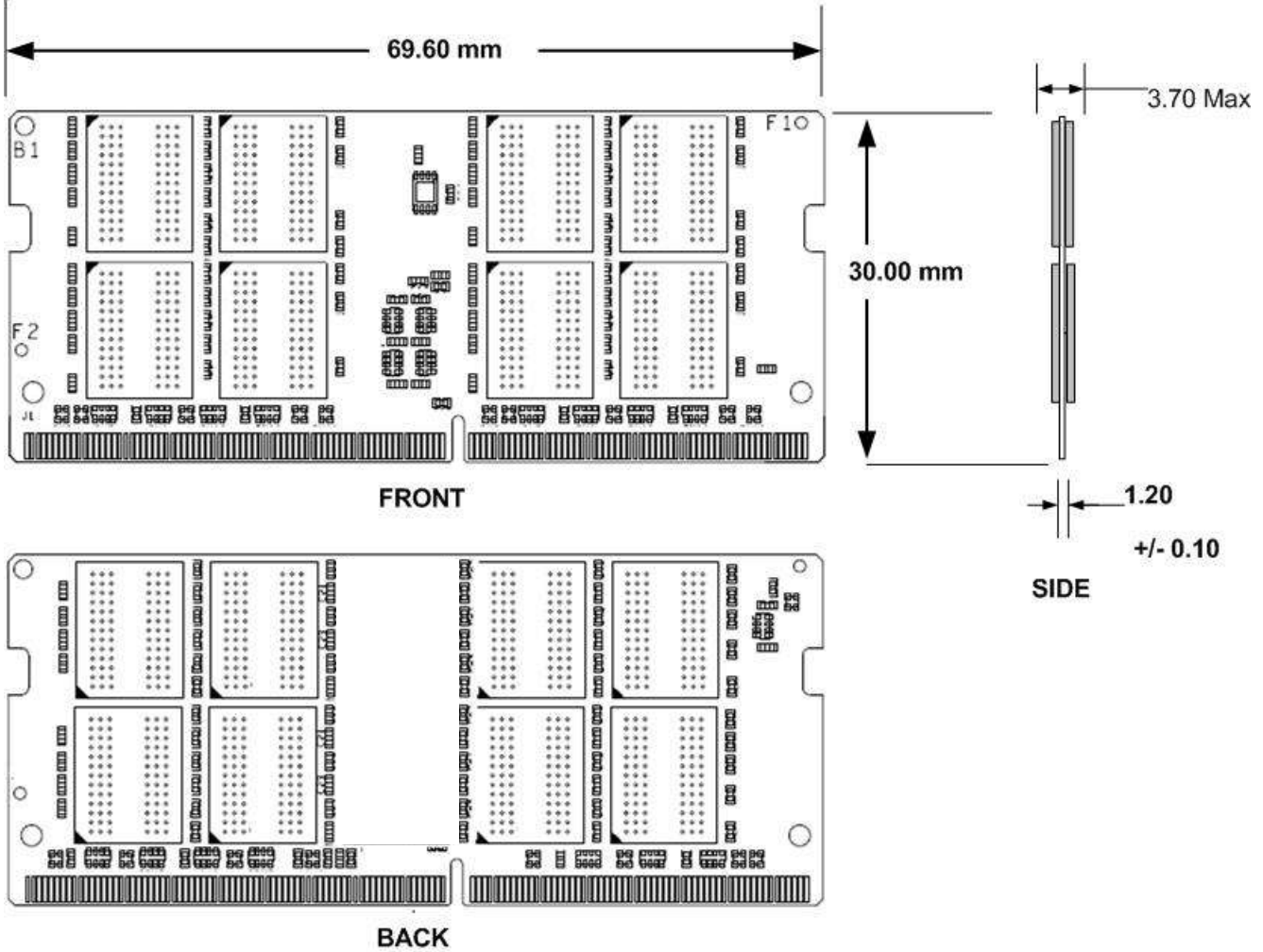

**Notes:**

- All dimensions in mm (inches)
- Tolerance is  $\pm 0.0127$ , unless otherwise stated
- Refer to JEDEC Standard Mechanical Outline MO-310 for other details

Datasheet	5/11/2017
PS9FUxx64x8xxx_VP	Viking Technology
Revision B	Page 13 of 41

## FUNCTIONAL BLOCK DIAGRAM

### BLOCK DIAGRAM, SINGLE RANK

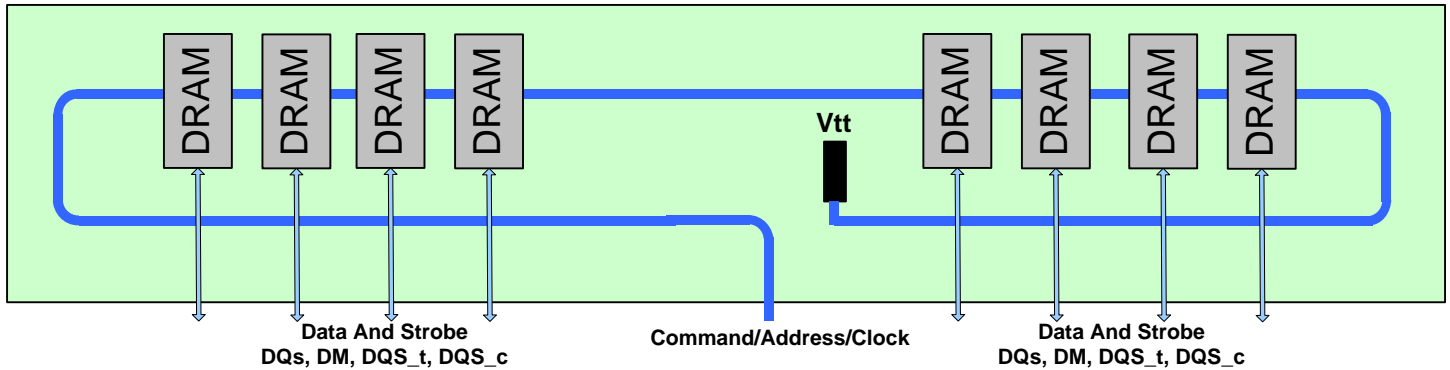

## DDR4 HOST MEMORY INTERFACE

### BLOCK DIAGRAM, DUAL RANK

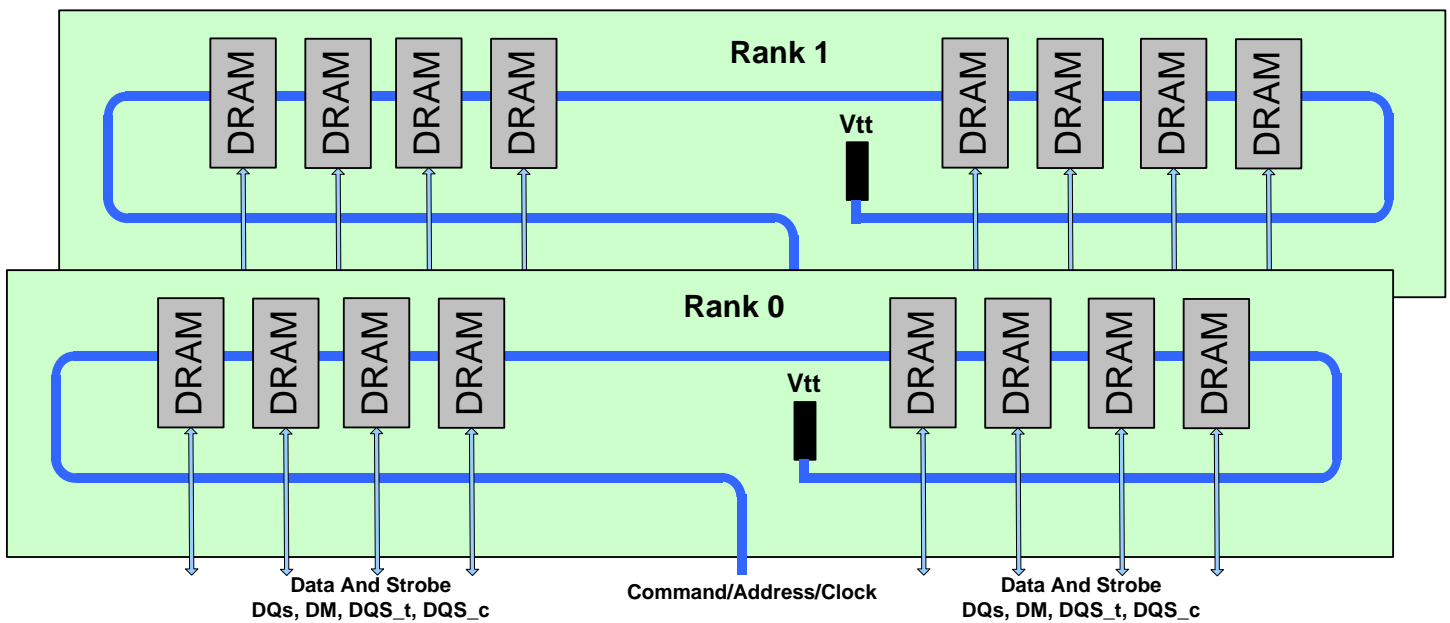

## DDR4 HOST MEMORY INTERFACE

Datasheet	5/11/2017
PS9FUxx64x8xxx_VP	Viking Technology
Revision B	Page 14 of 41



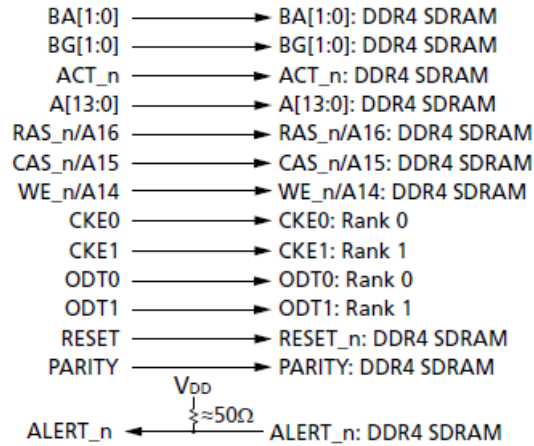

Rank 0: U1-U8  
Rank 1: U10-U17

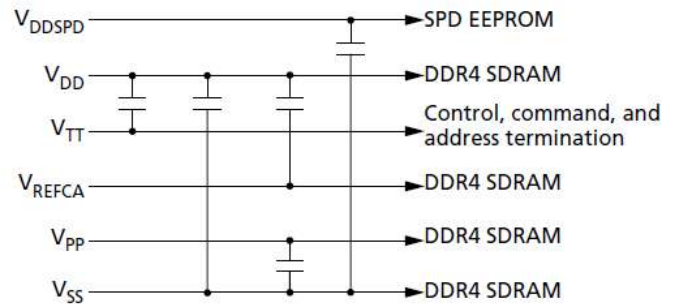
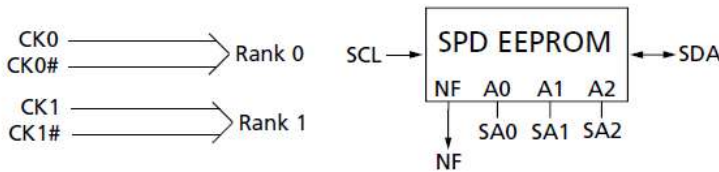

Clock, control, command, and address line terminations:

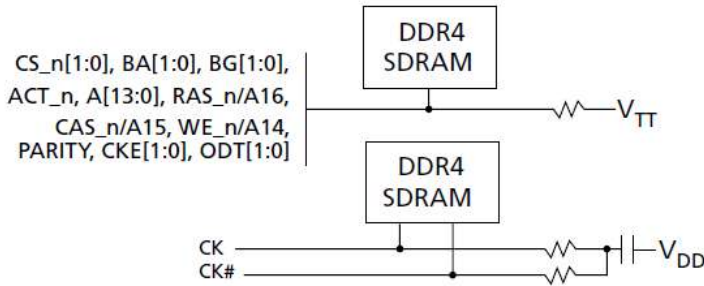

**Notes:**

- The ZQ ball on each DDR4 component is connected to an external 240Ω ±1% resistor that is tied to ground. It is used for the calibration of the component's ODT and output driver.

Datasheet	5/11/2017
PS9FUxx64x8xxx_VP	Viking Technology
Revision B	Page 15 of 41

## DQ Internal Vref Specifications

Parameter	Symbol	Min	Typ	Max	Unit	NOTE
Vref Max operating point Range 1	Vref_max_R1	-	-	92%	VDDQ	1, 11
Vref Min operating point Range 1	Vref_min_R1	60%	-	-	VDDQ	1,11
Vref Max operating point Range 2	Vref_max_R2	-	-	77%	VDDQ	1, 11
Vref Min operating point Range 2	Vref_min_R2	45%	-	-	VDDQ	1,11
Vref Stepsize	Vref_step	0.50%	0.65%	0.80%	VDDQ	2
Vref Set Tolerance	Vref_set_tol	-1.625%	0.00%	1.63%	VDDQ	3,4,6
		-0.15%	0.00%	0.15%	VDDQ	3,5,7
Vref Step Time	Vref_time-long	-	-	150	ns	9
	Vref_time-Short	-	-	60	ns	8
Vref Valid tolerance	Vref_val_tol	-0.15%	0.00%	0.15%	VDDQ	10

### Notes:

1. JESD8-24 specifies Vref to be 70% of VDDQ. Vref DC voltage referenced to VDDQ\_DC. VDDQ\_DC is 1.2V
2. Vref stepsize increment/decrement range. Vref at DC level.
3.  $Vref\_new = Vref\_old + n * Vref\_step$ ; n=number of step; if increment use "+"; If decrement use "-"
4. The minimum value of Vref setting tolerance= $Vref\_new - 1.625% * VDDQ$ .  
The maximum value of Vref setting tolerance= $Vref\_new + 1.625% * VDDQ$ . For n>4
5. The maximum value of Vref setting tolerance= $Vref\_new - 0.15% * VDDQ$ .  
The maximum value of Vref setting tolerance= $Vref\_new + 0.15% * VDDQ$ . For n&4 tbd
6. Measured by recording the min and max values of the Vref output over the range, drawing a straight line between those points and comparing all other Vref output settings to that line
7. Measured by recording the min and max values of the Vref output across 4 consecutive steps(n=4), drawing a straight line between those points and comparing all other Vref output settings to that line
8. Time from MRS command to increment of decrement one step size for Vref
9. Time from MRS command to increment of decrement more than one step size up to full range of Vref
10. Only applicable for DRAM component level test/characterization purpose.  
Not applicable for normal mode of operation. Vref valid is to qualify the step times which will be characterized at the component level.
11. DRAM range1 or 2 set by MRS bit MR6,A6.

Datasheet	5/11/2017
PS9FUxx64x8xxx_VP	Viking Technology
Revision B	Page 16 of 41



## OVERVIEW OF DDR4 SOUDIMM MODULE OPERATION

The DDR4 architecture is generally a point-to-point topology with a dedicated channel design. The highest system performance levels can be achieved with DDR4-2133 and beyond, when the system is configured as 1 SOUDIMM Per Channel (1DPC). DDR4 has more features than DDR3 with a pseudo-open drain (POD12) 1.2v I/O for the data channel, trained Vref, bank groups and write CRC. The POD12 interface only applies to the data channel. The address command channel behave like DDR3 using mid-point termination and mid-point Vref. The new bank group interleaving feature in DDR4 maximizes data transfer bandwidth.

DDR4 DRAM use pseudo-open drain (POD12) 1.2v drivers with Vdd terminations on DQ lines to increase data rates; unlike DDR3 DRAM that uses stub-series terminated logic drivers, The DRAM addressing scheme in DDR4 is organized into bank groups, Side A and Side B. The host DDR4 memory controller interleaves (multiplexes) among the bank groups to achieve high data rates. DDR4 architecture is a 8n prefetch with bank groups, including the use of two or four selectable bank groups. This will permit the DDR4 memory devices to have separate activation, read, write or refresh operations simultaneously underway in each of the unique bank groups to improve overall memory efficiency and bandwidth, especially when small memory granularities are used.

The data written to the SOUDIMM is read back the same way. However when writing to the internal registers with a "load mode" operation, a specific address is required. This requires the controller to know if the rank is mirrored or not. There is a bit assignment in the SPD that indicates whether the module has been designed with a mirrored feature or not.

DDR4 offers CRC parity as an optional feature on address command and data; (Error command blocking when parity enabled and post CA parity. If the SOUDIMM does not support CRC, the values of 0x00 will fill the CRC table. The new CA parity feature on the command/address bus provides a low-cost method of verifying the integrity of command and address transfers over a link, for all operations.

Some of the main attributes of DDR4 memory are:

- 1) Internally generated VrefDQ and Calibration.  
 VrefDQ is supplied by the DRAM internally.  
 VrefCA is supplied by the board.
- 2) The ACT\_n activate pin replaces RAS#, CAS#, and WE# commands,
- 3) Alert\_n for error checking
- 4) Bank group Interleaving
- 5) Improved training modes upon power-up
- 5) Nominal and dynamic ODT: Improvements to the ODT protocol and a new Park Mode allow for a nominal termination and dynamic write termination without having to drive the ODT pin
- 6) DQ bus gear-down mode for 2667 Mhz data rates and beyond
- 7) External VPP at 2.5V (for wordline boost)
- 8) 1.2V VDD power with power-saving features that include MPSM Maximum Power Savings Mode, Low Power Auto Self Refresh, Temperature Controlled Refresh, Fine Granularity Refresh, and CMD/ADDT latency. DLL off mode.

### Important Note:

Longer boot-up times may be experienced in certain situations due to controller initiated functions such as VrefDQ calibration, write leveling and other trainings for the SOUDIMM.

Datasheet	5/11/2017
PS9FUxx64x8xxx_VP	Viking Technology
Revision B	Page 17 of 41

## DDR4 MODE REGISTERS

	A12	A11	A10	A9	A8	A7	A6	A5	A4	A3	A2	A1	A0
<b>MR0</b>	RFU	Write Recovery and RTP			DLL Reset	Test Mode	CAS Latency CL			Burst Type	CL	Burst Length BL	
<b>MR1</b>	Qoff	TDQS	Rtt_NOM			Write Leveling	RFU	RFU	Additive Latency		Ron		DLL Enable
<b>MR2</b>	Write CRC	RFU	Rtt_WR		RFU	Auto Self Refresh		CWL			RFU	RFU	RFU
<b>MR3</b>	MPR Read Format		Write CMD Latency with CRC and DM		Fine Granularity Refresh			Temp Sensor	Per-DRAM Addr Mode	Gear down	MPR Enable	MPR Page	
<b>MR4</b>	Write Preamble	Read Preamble	Read Preamble Training Enable	Self Refresh Abort Enable	CS-to-Address Latency CAL			RFU	VrefDQ Monitor Enable	Temp Refresh Mode	Temp. Refresh Range	Max Power Down Enable	RFU
<b>MR5</b>	Read DBI Enable	Write DBI Enable	Data Mask Enable	Parity Persistent Error	Rtt_PARK			ODT input in Power Down	Panty Error Status	CRC Error Clear	CMD Address Parity Latency		
<b>MR6</b>	tCCD_L and tDLLK Timing			RFU	RFU	VrefDQ Training enable	VrefDQ Training Range	VretDQ Training Value					
<b>MR7</b>	Manufacturing use only to program the RCD												

### Notes:

- Refer to JEDEC documentation for detail of the control/status bits

Datasheet	5/11/2017
PS9FUxx64x8xxx_VP	Viking Technology
Revision B	Page 18 of 41

## DC OPERATING CONDITIONS AND CHARACTERISTICS

### ABSOLUTE MAXIMUM RATINGS

Parameter	Symbol	Value	Unit	Notes
Voltage on any pin relative to GND	Vin, Vout	-0.3 ~ 1.5	V	1,
Voltage on VDD supply relative to GND	VDD	-0.3 ~ 1.5	V	1,3
Voltage on VDDQ supply relative to GND	VDDQ	-0.3 ~ 1.5	V	1,3
Voltage on VPP supply relative to GND	VPP	-0.3 ~ 3.0	V	4
Module operating temperature (ambient)	T <sub>opr</sub>	0 ~ 55	°C	1,5
Storage temperature	T <sub>stg</sub>	-55 ~ +100	°C	1,2

#### Notes:

- Permanent device damage may occur if 'ABSOLUTE MAXIMUM RATINGS' are exceeded. Functional operation should be restricted to recommended operating condition.  
Exposure to higher than recommended voltage for extended periods of time could affect device reliability. Stresses greater than those listed under "Absolute Maximum Ratings" may cause permanent damage to the device. This is a stress rating only and functional operation of the device at these or any other conditions above those indicated in the operational sections of this specification is not implied. Exposure to absolute maximum rating conditions for extended periods may affect reliability
- Storage Temperature is the case surface temperature on the center/top side of the DRAM. For the measurement conditions, please refer to JESD51- 2 standard.
- VDD and VDDQ must be within 300 mV of each other at all times and VREFCA must be not greater than 0.6 x VDDQ, When VDD and VDDQ are less than 500 mV; VREF may be equal to or less than 300 mV
- VPP must be equal or greater than VDD/VDDQ at all times
- Refer to JEDEC JC451 specification

### DRAM Component Operating Temperature Range

Symbol	Parameter	Rating	Units	Note
T <sub>oper</sub>	Normal Operating Temperature Range	0 to 85	°C	1,2
	Extended Temperature Range	85 to 95	°C	1,3

#### Notes:

- Operating Temperature TOPER is the case surface temperature on the center / top side of the DRAM. For measurement conditions, please refer to the JEDEC document JE51-2.
- The Normal Temperature Range specifies the temperatures where all DRAM specifications will be supported. During operation, the DRAM case temperature must be maintained between 0 - 85oC under all operating conditions.
- Some applications require operation of the DRAM in the Extended Temperature Range between 85oC and 95oC case temperature. Full specifications are guaranteed in this range, but the following additional conditions apply:
  - Refresh commands must be doubled in frequency, therefore reducing the Refresh interval tREFI to 3.9 μs. It is also possible to specify a component with 1X refresh (tREFI to 7.8μs) in the Extended Temperature Range. Please refer to the DIMM SPD for option availability.
  - If Self-Refresh operation is required in the Extended Temperature Range, then it is mandatory to either use the Manual Self-Refresh mode with Extended Temperature Range capability (MR2 A6 = 0b and MR2 A7 = 1b) or enable the optional Auto Self-Refresh mode (MR2 A6 = 1b and MR2 A7 = 0b). DDR4 SDRAMs support Auto Self-Refresh and in Extended Temperature Range and please refer to component datasheet and/or the DIMM SPD for tREFI requirements in the Extended Temperature Range

### tREFI by Device Density

Parameter	Symbol	2Gb	4Gb	8Gb	16Gb	Units	
Average periodic refresh interval	tREFI	0°C ≤ T <sub>case</sub> ≤ 85°C	7.8	7.8	7.8	7.8	μs
		85°C ≤ T <sub>case</sub> ≤ 95°C	3.9	3.9	3.9	3.9	μs

Datasheet	5/11/2017
PS9FUxx64x8xxx_VP	Viking Technology
Revision B	Page 19 of 41

## AC & DC Operating Conditions

### DC OPERATING CONDITIONS AND CHARACTERISTICS (POD12)

Symbol	Parameter	Rating			Units	Notes
		Min	Typ	Max		
VDD	Supply Voltage VDD: PC4:1.2V±5%,	1.14	<b>1.2</b>	1.26	v	1,2,3
VDDQ	Supply Voltage for Output. Values in () are at 70% of VDD	1.14 (0.798)	1.2 (0.84)	1.26 (0.882)	v	1
VPP	2.5V +10%, -5%	2.375	2.5	2.75	v	3
VDDSPD	@2.5V	2.2	-	3.6	v	

**Notes:**

1. JESD8-24 specifies Vref to be 70% of VDDQ. Under all conditions VDDQ must be less than or equal to VDD.
2. VDDQ tracks with VDD. AC parameters are measured with VDD and VDDQ tied together.
3. DC bandwidth is limited to 20MHz.,
4. POD12 1.2 V Pseudo Open Drain Interface has a VDDQ value of 1.2V but the reference voltage allows POD12 to be used with other VDDQ values. POD12 signals have pull-up-only parallel input termination and have an asymmetric output drive impedance. For example, if the output drivers were using a 60 ohm pull-up drive impedance then the pull-down drivers would be expected to produce a 40 ohm pull-down drive impedance. POD12 does not explicitly call for series termination resistors, so it is suitable for point-to-point as well as multi-drop stub environments which may require some additional termination.

Datasheet	5/11/2017
PS9FUxx64x8xxx_VP	Viking Technology
Revision B	Page 20 of 41

## DC CHARACTERISTICS, IDD CURRENTS

### IDD DEFINITIONS

Symbol	Parameter
IDD0	One bank ACTIVATE-PRECHARGE current
IPP0	One bank ACTIVATE-PRECHARGE, Word Line Boost, IPP current
IDD1	One bank ACTIVATE-READ-PRECHARGE current
IDD2N	Precharge standby current
IDD2NT	Precharge standby ODT current
IDD2P	Precharge power-down current
IDD2Q	Precharge quiet standby current
IDD3N	Active standby current
IPP3N	Active standby IPP current
IDD3P	Active power-down current
IDD4R	Burst read current
IDDQ4R	Burst read IDDQ current
IDD4W	Burst write current
IDD5B	Burst refresh current (1x REF)
IPP5B	Burst refresh IPP current (1 x REF)
IDD6N	Self refresh current: Normal temperature range (0°C to +85°C)
IDD6E	Self refresh current: Extended temperature range (0°C to +95°C)
IDD6R	Self refresh current: Reduced temperature range (0°C to +45°C)
IDD6A	Auto self refresh current (25°C)
IDD6A	Auto self refresh current (45°C)
IDD6A	Auto self refresh current (75°C)
IDD7	Bank interleave read current
IPP7	Bank interleave read IPP current
IDD8	Maximum power-down current

#### Notes:

- DDR4 IDD and IDDQ specs include the same DDR3 IDD and IDDQ specs with these exceptions:
  - IDD2P0 and IDD2P1 are replaced with a single IDD2P. There's no longer any difference in power for the DLL because of better DLL power management inside the DRAM device without any benefit for using slow exit.
  - IDD6 is renamed IDD6N Self Refresh Current: Normal Temperature Range
  - IDD6ET is renamed IDD6E Self-Refresh Current: Extended Temperature Range
  - IDD6TC is renamed IDD6AAut0 Self-Refresh Current
  - IDD8 is redefined from (optional) RESET Low Current to IDD8 Maximum Power Down Current, TBD
- IDD values are an average (not peak) current drawn throughout the entire time that it takes to execute the set of conditions specified by JEDEC standards.
- Consult with Viking for tools to help specify the Total Design Power (TDP)

Datasheet	5/11/2017
PS9FUxx64x8xxx_VP	Viking Technology
Revision B	Page 21 of 41

### ***I<sub>DD6</sub>* Specification**

<b>Symbol</b>	<b>Temperature Range</b>	<b>Value</b>	<b>Unit</b>	<b>Notes</b>
IDD6N	0 - 85 °C	22	mA	3,4
IDD6E	0 - 95 °C	33	mA	4,5,6
IDD6R	0 - 45°C	10	mA	4,6,9
IDD6A	0 °C ~ Ta	9	mA	4,6,7,8
	Tb ~ Ty	10	mA	4,6,7,8
	Tz ~ TOPERmax	16	mA	4,6,7,8

**Notes:**

1. Some IDD currents are higher for x16 organization due to larger page-size architecture.
2. Max. values for IDD currents considering worst case conditions of process, temperature and voltage.
3. Applicable for MR2 settings A6=0 and A7=0.
4. Supplier data sheets include a max value for IDD6.
5. Applicable for MR2 settings A6=0 and A7=1. IDD6ET is only specified for devices which support the Extended Temperature Range feature.
6. Refer to the supplier data sheet for the value specification method (e.g. max, typical) for IDD6ET and IDD6TC
7. Applicable for MR2 settings A6=1 and A7=0. IDD6TC is only specified for devices which support the Auto Self Refresh feature.
8. The number of discrete temperature ranges supported and the associated Ta - Tz values are supplier/design specific. Temperature ranges are specified for all supported values of TOPER. Refer to supplier data sheet for more information.
9. Applicable for MR2 settings TBD. IDD6R is verified by design and characterization, and may not be subject to production test.

Datasheet	5/11/2017
PS9FUxx64x8xxx_VP	Viking Technology
Revision B	Page 22 of 41

### IDD CURRENTS, SINGLE RANK, 4Gbit

Symbol	DDR4-1866	DDR4-2133	DDR4-2400	Units
IDD0	464	480	512	mA
IPP0	32	32	32	mA
IDD1	504	520	544	mA
IDD2N	352	368	400	mA
IDD2NT	400	432	464	mA
IDD2P	240	240	256	mA
IDD2Q	312	312	328	mA
IDD3N	488	504	536	mA
IPP3N	24	24	24	mA
IDD3P	352	352	352	mA
IDD4R	1120	1200	1280	mA
IDDQ4R	256	288	320	mA
IDD4W	1248	1408	1568	mA
IDD5B	1520	1520	1536	mA
IPP5B	176	176	176	mA
IDD6N	160	160	160	mA
IDD6E	216	216	216	mA
IDD6R	80	80	80	mA
IDD6A (25°C)	72	72	72	mA
IDD6A (45°C)	80	80	80	mA
IDD6A (75°C)	128	128	128	mA
IDD7	1280	1480	1680	mA
IPP7	80	96	112	mA
IDD8	144	144	144	mA

**Notes:**

- Users should refer to the DRAM supplier data sheet and/or the DIMM SPD to determine if DDR4 SDRAM devices support the following options or requirements referred to in this material.
- Values as per Micron Datasheet Revision "A".

Datasheet	5/11/2017
PS9FUxx64x8xxx_VP	Viking Technology
Revision B	Page 23 of 41

### IDD CURRENTS, 2 RANK, 4Gbit

Symbol	DDR4-1866	DDR4-2133	DDR4-2400	Units
IDD0 <sup>1</sup>	704	720	768	mA
IPP0 <sup>1</sup>	272	272	288	mA
IDD1 <sup>1</sup>	744	760	800	mA
IDD2N <sup>2</sup>	704	736	800	mA
IDD2NT <sup>1</sup>	640	672	720	mA
IDD2P <sup>2</sup>	480	480	512	mA
IDD2Q <sup>2</sup>	624	624	656	mA
IDD3N <sup>2</sup>	976	1008	1072	mA
IPP3N <sup>2</sup>	48	48	48	mA
IDD3P <sup>2</sup>	704	704	704	mA
IDD4R <sup>1</sup>	1360	1440	1536	mA
IDDQ4R <sup>1</sup>	496	528	576	mA
IDD4W <sup>1</sup>	1488	1648	1824	mA
IDD5B <sup>1</sup>	1760	1760	1792	mA
IPP5B <sup>1</sup>	416	416	432	mA
IDD6N <sup>2</sup>	320	320	320	mA
IDD6E <sup>2</sup>	432	432	432	mA
IDD6R <sup>2</sup>	160	160	160	mA
IDD6A <sup>2</sup> (25°C)	144	144	144	mA
IDD6A <sup>2</sup> (45°C)	160	160	160	mA
IDD6A <sup>2</sup> (75°C)	256	256	256	mA
IDD7 <sup>1</sup>	1520	1720	1936	mA
IPP7 <sup>1</sup>	320	336	368	mA
IDD8 <sup>2</sup>	288	288	288	mA

**Notes:**

1. One module rank in the active IDD/PP, the other rank in IDD2P/PP3N.
2. All ranks in this IDD/PP condition.
3. Values as per Micron Datasheet Revision "A".



### IDD CURRENTS, SINGLE RANK, 8Gbit

Symbol	DDR4-2133	DDR4-2400	DDR4-2600	Units
IDD0	440	480	520	mA
IPP0	24	24	24	mA
IDD1	560	600	640	mA
IDD2N	360	400	440	mA
IDD2NT	440	480	520	mA
IDD2P	200	240	280	mA
IDD2Q	360	360	400	mA
IDD3N	440	440	480	mA
IPP3N	24	24	24	mA
IDD3P	280	320	320	mA
IDD4R	1200	1280	1400	mA
IDDQ4R	480	520	560	mA
IDD4W	1200	1200	1400	mA
IDD5B	1800	1800	1800	mA
IPP5B	240	240	240	mA
IDD6N	240	240	240	mA
IDD6E	280	280	280	mA
IDD6R	200	200	200	mA
IDD6A (25°C)	160	160	160	mA
IDD6A (45°C)	200	200	200	mA
IDD6A (75°C)	280	280	280	mA
IDD7	1600	1640	1720	mA
IPP7	120	120	120	mA
IDD8	160	160	160	mA

**Notes:**

1. Users should refer to the DRAM supplier data sheet and/or the DIMM SPD to determine if DDR4 SDRAM devices support the following options or requirements referred to in this material.
2. Values as per Micron Datasheet for the MT40A1G8 DDR4 SDRAM only and are computed from values specified in the 8Gb (1 Gig x 8) component data sheet

Datasheet	5/11/2017
PS9FUxx64x8xxx_VP	Viking Technology
Revision B	Page 25 of 41

### IDD CURRENTS, DUAL RANK, 8Gbit

Symbol	DDR4-2133	DDR4-2400	DDR4-2600	Units
IDD0	640	720	800	mA
IPP0	48	48	48	mA
IDD1	760	840	920	mA
IDD2N	720	800	880	mA
IDD2NT	640	720	800	mA
IDD2P	400	480	560	mA
IDD2Q	720	720	800	mA
IDD3N	880	880	960	mA
IPP3N	48	48	48	mA
IDD3P	560	640	640	mA
IDD4R	1400	1440	1680	mA
IDDQ4R	680	760	840	mA
IDD4W	1400	1520	1680	mA
IDD5B	2000	2040	2080	mA
IPP5B	264	264	264	mA
IDD6N	480	480	480	mA
IDD6E	560	560	560	mA
IDD6R	400	400	400	mA
IDD6A (25°C)	320	320	320	mA
IDD6A (45°C)	400	400	400	mA
IDD6A (75°C)	560	560	560	mA
IDD7	1800	1880	2000	mA
IPP7	144	144	144	mA
IDD8	320	320	320	mA

**Notes:**

1. One module rank in the active IDD/PP, the other rank in IDD2P/PP3N.
2. All ranks in this IDD/PP condition.
3. Users should refer to the DRAM supplier data sheet and/or the DIMM SPD to determine if DDR4 SDRAM devices support the following options or requirements referred to in this material.
4. Values as per Micron Datasheet for the MT40A1G8 DDR4 SDRAM only and are computed from values specified in the 8Gb (1 Gig x 8) component data sheet

Datasheet	5/11/2017
PS9FUxx64x8xxx_VP	Viking Technology
Revision B	Page 26 of 41

## Input/Output Capacitance

Symbol	Parameter	DDR4-1600, 1867, 2133		DDR4-2400,2667		DDR4-3200		Units	Note
		Min	Max	Min	Max	Min	Max		
C <sub>IO</sub>	Input/output capacitance	0.7	1.4	0.7	1.3	TBD	TBD	pF	1,2,3
C <sub>DIO</sub>	Input/output capacitance delta	-0.1	0.1	-0.1	0.1	TBD	TBD	pF	1,2,3,1 1
C <sub>DDQS</sub>	Input/output capacitance delta DQS and DQS#		0.05		0.05	TBD	TBD	pF	1,2,3,5
C <sub>CK</sub>	Input capacitance, CK and CK#	0.2	0.8	0.2	0.8	TBD	TBD	pF	1,3
C <sub>DCK</sub>	Input capacitance delta CK and CK#		0.05		0.05	TBD	TBD	pF	1,3,4
C <sub>I</sub>	Input capacitance(CTRL, ADD, CMD pins only)	0.2	0.8	0.2	0.7	TBD	TBD	pF	1,3,6
C <sub>DI_CTRL</sub>	Input capacitance delta(All CTRL pins only)	-0.1	0.1	-0.1	0.1	TBD	TBD	pF	1,3,7,8
C <sub>DI_ADD_CMD</sub>	Input capacitance delta(All ADD/CMD pins only)	-0.1	0.1	-0.1	0.1	TBD	TBD	pF	1,2,9, 10
C <sub>ALERT</sub>	Input/output capacitance of ALERT	0.5	1.5	0.5	1.5	TBD	TBD	pF	1,3
C <sub>ZQ</sub>	Input/output capacitance of ZQ	0.5	1.5	0.5	1.5	TBD	TBD	pF	1,3,12

### Notes:

1. This parameter is not subject to production test. It is verified by design and characterization. The silicon only capacitance is validated by de-embedding the package L & C parasitic. The capacitance is measured with VDD, VDDQ, VSS, VSSQ applied with all other signal pins floating. Measurement procedure tbd.
2. DQ, DM, DQS\_T, DQS\_C, TDQS\_T, TDQS\_C. Although the DM, TDQS\_T and TDQS\_C pins have different functions, the loading matches DQ and DQS
3. This parameter applies to monolithic devices only; stacked/dual-die devices are not covered here.
4. Absolute value C<sub>K\_T-CK\_C</sub>
5. Absolute value of C<sub>IO(DQS\_T)</sub>-C<sub>IO(DQS\_C)</sub>
6. C<sub>I</sub> applies to ODT, CS\_n, CKE, A0-A17, BA0-BA1, BG0-BG1, RAS\_n, CAS\_n, WE\_n.
7. C<sub>DI\_CTRL</sub> applies to ODT, CS\_n and CKE
8. C<sub>DI\_CTRL</sub> = C<sub>I(CTRL)</sub>-0.5\*(C<sub>I(CLK\_T)</sub>+C<sub>I(CLK\_C)</sub>)
9. C<sub>DI\_ADD\_CMD</sub> applies to, A0-A17, BA0-BA1, BG0-BG1, RAS\_n, CAS\_n, WE\_n.
10. C<sub>DI\_ADD\_CMD</sub> = C<sub>I(ADD\_CMD)</sub>-0.5\*(C<sub>I(CLK\_T)</sub>+C<sub>I(CLK\_C)</sub>)
11. C<sub>DIO</sub> = C<sub>IO(DQ,DM)</sub>-0.5\*(C<sub>IO(DQS\_T)</sub>+C<sub>IO(DQS\_C)</sub>)
12. Maximum external load capacitance on ZQ pin: tbd pF

## DC and AC Specifications for the SMBus Interface

The specifications for the SMBus follow JEDEC standards.

Datasheet	5/11/2017
PS9FUxx64x8xxx_VP	Viking Technology
Revision B	Page 27 of 41

### Speed Bins by Speed Grade

#### DDR4-1600 Speed Bins and Operating Conditions

Speed Bin			DDR4-1600		Unit	NOTE	
CL-nRCD-nRP			11-11-11				
Parameter	Symbol	Min	Max				
Internal read command to first data	tAA	13.75 <sup>14</sup> (13.50) <sup>5,12</sup>	18	ns			
Internal read command to first data with read DBI enabled	tAA_DBI	tAA(min) + 2nCK	tAA(max) + 2nCK	ns			
ACT to internal read or write delay time	tRCD	13.75 (13.50) <sup>5,12</sup>	-	ns			
PRE command period	tRP	13.75 (13.50) <sup>5,12</sup>	-	ns			
ACT to PRE command period	tRAS	35	9 x tREFI	ns			
ACT to ACT or REF command period	tRC	48.75 (48.50) <sup>5,12</sup>	-	ns			
	Normal	Read DBI					
CWL = 9	CL = 9	CL = 11 (Optional) <sup>5</sup>	tCK(AVG)	Reserved		ns	1,2,3,4,11,14
	CL = 10	CL = 12	tCK(AVG)	1.5	1.6	ns	1,2,3,4,11
CWL = 9,11	CL = 10	CL = 12	tCK(AVG)	Reserved		ns	1,2,3,4
	CL = 11	CL = 13	tCK(AVG)	1.25	<1.5	ns	1,2,3,4
	CL = 12	CL = 14	tCK(AVG)	1.25	<1.5	ns	1,2,3
Supported CL Settings			(9),11,12		nCK	13,14	
Supported CL Settings with read DBI			(11),13,14		nCK	13	
Supported CWL Settings			9,11		nCK		

### DDR4-1866 Speed Bins and Operating Conditions

Speed Bin			DDR4-1866		Unit	NOTE	
CL-nRCD-nRP			13-13-13				
Parameter	Symbol		Min	Max			
Internal read command to first data	tAA		13.92 <sup>14</sup> (13.50) <sup>5,12</sup>	18	ns		
Internal read command to first data with read DBI enabled	tAA_DBI		tAA(min) + 2nCK	tAA(max) + 2nCK	ns		
ACT to internal read or write delay time	tRCD		13.92 (13.50) <sup>5,12</sup>	-	ns		
PRE command period	tRP		13.92 (13.50) <sup>5,12</sup>	-	ns		
ACT to PRE command period	tRAS		34	9 x tREFI	ns		
ACT to ACT or REF command period	tRC		47.92 (47.50) <sup>5,12</sup>	-	ns		
	Normal	Read DBI					
CWL=9	CL=9	CL=11 (Optional) <sup>5</sup>	tCK(AVG)	Reserved		ns	1,2,3,4,11,14
	CL=10	CL=12	tCK(AVG)	1.5	1.6	ns	1,2,3,4,11
CWL=9,11	CL=10	CL=12	tCK(AVG)				4
	CL=11	CL=13	tCK(AVG)	1.25	<1.5	ns	1,2,3,4,6
				(Optional) <sup>5,12</sup>			
CL=12	CL=14	tCK(AVG)	1.25	<1.5	ns	1,2,3,6	
CWL=10,12	CL=12	CL=14	tCK(AVG)	Reserved		ns	1,2,3,4
	CL=13	CL=15	tCK(AVG)	1.071	<1.25	ns	1,2,3,4
	CL=14	CL=16	tCK(AVG)	1.071	<1.25	ns	1,2,3
Supported CL Settings			9,11,12,13,14		nCK	13,14	
Supported CL Settings with read DBI			11,13,14,15,16		nCK	13	
Supported CWL Settings			9,10,11,12		nCK		

### DDR4-2133 Speed Bins and Operating Conditions

Speed Bin			DDR4-2133		Unit	NOTE	
CL-nRCD-nRP			15-15-15				
Parameter	Symbol		Min	Max			
Internal read command to first data	tAA		14.06 <sup>14</sup> (13.75) <sup>5,12</sup>	18	ns		
Internal read command to first data with read DBI enabled	tAA_DBI		tAA(min) + 3nCK	tAA(max) + 3nCK	ns		
ACT to internal read or write delay time	tRCD		14.06 (13.75) <sup>5,12</sup>	-	ns		
PRE command period	tRP		14.06 (13.75) <sup>5,12</sup>	-	ns		
ACT to PRE command period	tRAS		33	9 x tREFI	ns		
ACT to ACT or REF command period	tRC		47.06 (46.75) <sup>5,12</sup>	-	ns		
		Normal					Read DBI
CWL = 9	CL = 9	CL = 11 (Optional) <sup>5</sup>	tCK(AVG)	Reserved		ns	1,2,3,4,11,14
	CL = 10	CL = 12	tCK(AVG)	1.5	1.6	ns	1,2,3,11
CWL = 9,11	CL = 11	CL = 13	tCK(AVG)			ns	1,2,3,4,7
			tCK(AVG)	(Optional) <sup>5,12</sup>			
	CL = 12	CL = 14	tCK(AVG)	1.25	<1.5	ns	1,2,3,7
CWL = 10,12	CL = 13	CL = 15	tCK(AVG)	1.071	<1.25	ns	1,2,3,4,7
			tCK(AVG)	(Optional) <sup>5,12</sup>			
	CL = 14	CL = 16	tCK(AVG)	1.071	<1.25	ns	1,2,3,7
CWL = 11,14	CL = 14	CL = TBD	tCK(AVG)	Reserved		ns	1,2,3,4
	CL = 15	CL = TBD	tCK(AVG)	0.938	<1.071	ns	1,2,3,4
	CL = 16	CL = TBD	tCK(AVG)	0.938	<1.071	ns	1,2,3
Supported CL Settings			(9),(11),12,(13),14,15,16		nCK	13,14	
Supported CL Settings with read DBI			(11),(13),14,(15),16,18,19		nCK		
Supported CWL Settings			9,10,11,12,14		nCK		

### DDR4-2400 Speed Bins and Operating Conditions

Speed Bin			DDR4-2400		Unit	NOTE	
CL-nRCD-nRP			17-17-17				
Parameter	Symbol		Min	Max			
Internal read command to first data	tAA		14.16 <sup>14</sup> (13.75) <sup>5,12</sup>	18	ns		
Internal read command to first data with read DBI enabled	tAA_DBI		tAA(min) + 3nCK	tAA(max) + 3nCK	ns		
ACT to internal read or write delay time	tRCD		14.16 (13.75) <sup>5,12</sup>	-	ns		
PRE command period	tRP		14.16 (13.75) <sup>5,12</sup>	-	ns		
ACT to PRE command period	tRAS		32	9 x tREFI	ns		
ACT to ACT or REF command period	tRC		46.16 (45.75) <sup>5,12</sup>	-	ns		
	Normal	Read DBI					
CWL = 9	CL = 9	CL = 11 (Optional) <sup>5</sup>	tCK(AVG)	Reserved		ns	1,2,3,4,11,14
	CL = 10	CL = 12	tCK(AVG)	1.5	1.6	ns	1,2,3,11
CWL = 9,11	CL = 11	CL = 13	tCK(AVG)			ns	1,2,3,4,7
			tCK(AVG)	(Optional) <sup>5,12</sup>			
CWL = 10,12	CL = 12	CL = 14	tCK(AVG)	1.25	<1.5	ns	1,2,3,7
			tCK(AVG)	1.071	<1.25	ns	1,2,3,4,7
CWL = 10,12	CL = 13	CL = 15	tCK(AVG)	1.071	<1.25	ns	1,2,3,4,7
			tCK(AVG)	(Optional) <sup>5,12</sup>			
CWL = 10,12	CL = 14	CL = 16	tCK(AVG)	1.071	<1.25	ns	1,2,3,7
			tCK(AVG)	(Optional) <sup>5,12</sup>			
CWL = 11,14	CL = 14	CL = 17	tCK(AVG)	Reserved		ns	1,2,3,4
	CL = 15	CL = 18	tCK(AVG)	0.938	<1.071	ns	1,2,3,4
	CL = 16	CL = 19	tCK(AVG)	0.938	<1.071	ns	1,2,3
CWL = 12,16	CL = 15	CL = 18	tCK(AVG)	Reserved		ns	1,2,3,4
	CL = 16	CL = 19	tCK(AVG)	Reserved		ns	1,2,3,4
	CL = 17	CL = 20	tCK(AVG)	0.833	<0.938	ns	1,2,3
	CL = 18	CL = 21	tCK(AVG)	0.833	<0.938	ns	1,2,3,4
Supported CL Settings			(10),(11),12,(13),14,15,16,17,18		nCK	13,14	
Supported CL Settings with read DBI			(12),(13),14,(15),16,18,19,20,21		nCK		
Supported CWL Settings			9,10,11,12,14,16		nCK		

Datasheet	5/11/2017
PS9FUxx64x8xxx_VP	Viking Technology
Revision B	Page 31 of 41

## Timing Parameters by Speed Grade

Speed		DDR4-1600		DDR4-1866		DDR4-2133		Units	Note	
Parameter	Symbol	MIN	MAX	MIN	MAX	MIN	MAX			
<b>Clock Timing</b>										
Minimum Clock Cycle Time (DLL off mode)	tCK(DLL_OFF)	8	-	8	-	8	-	ns	23	
Average Clock Period	tCK(avg)	See Speed Bins Table							ps	
Average high pulse width	tCH(avg)	0.48	0.52	0.48	0.52	0.48	0.52	tCK(avg)		
Average low pulse width	tCL(avg)	0.48	0.52	0.48	0.52	0.48	0.52	tCK(avg)		
Absolute Clock Period	tCK(abs)	tCK(avg)min + tJIT(per)min_tot	tCK(avg)max + tJIT(per)max_tot	tCK(avg)min + tJIT(per)min_tot	tCK(avg)max + tJIT(per)max_tot	tCK(avg)min + tJIT(per)min_tot	tCK(avg)max + tJIT(per)max_tot	tCK		
Absolute clock HIGH pulse width	tCH(abs)	0.45	-	0.45	-	0.45	-	tCK(avg)	24	
Absolute clock Low pulse width	tCL(abs)	0.45	-	0.45	-	0.45	-	tCK(avg)	25	
Clock Period Jitter- total	tJIT(per)_tot	-0.1	0.1	-0.1	0.1	-0.1	0.1	UI	26	
Clock Period Jitter- deterministic	tJIT(per)_dj	tbd						UI	27	
Clock Period Jitter during DLL locking period	tJIT(per, lck)	tbd						UI		
Cycle to Cycle Period Jitter	tJIT(cc)_tot	0.2		0.2		0.2		UI	26	
Cycle to Cycle Period Jitter- deterministic	tJIT(cc)_dj	tbd						UI	27	
Cycle to Cycle Period Jitter during DLL locking period	tJIT(cc, lck)	tbd						UI		
Duty cycle Jitter	tJIT(duty)	tbd						UI		
Cumulative error across 2 cycles	tERR(2per)	tbd						UI		
Cumulative error across 3 cycles	tERR(3per)	tbd						UI		
Cumulative error across 4 cycles	tERR(4per)	tbd						UI		
Cumulative error across 5 cycles	tERR(5per)	tbd						UI		
Cumulative error across 6 cycles	tERR(6per)	tbd						UI		
Cumulative error across 7 cycles	tERR(7per)	tbd						UI		
Cumulative error across 8 cycles	tERR(8per)	tbd						UI		
Cumulative error across 9 cycles	tERR(9per)	tbd						UI		
Cumulative error across 10 cycles	tERR(10per)	tbd						UI		
Cumulative error across 11 cycles	tERR(11per)	tbd						UI		
Cumulative error across 12 cycles	tERR(12per)	tbd						UI		
Cumulative error across n = 13, 14 ... 49, 50 cycles	tERR(nper)	tbd						UI		
<b>Command and Address Timing</b>										
CAS_n to CAS_n command delay for same bank group	tCCD_L	5	-	5	-	6	-	nCK		
CAS_n to CAS_n command delay for different bank group	tCCD_S	4	-	4	-	4	-	nCK		
ACTIVATE to ACTIVATE Command delay to different bank group for 2KB page size	tRRD_S(2K)	Max(4nCK,6ns)	-	Max(4nCK,5.3ns)	-	Max(4nCK,5.3ns)	-	nCK		
ACTIVATE to ACTIVATE Command delay to different bank group for 1KB page size	tRRD_S(1K)	Max(4nCK,5ns)	-	Max(4nCK,4.2ns)	-	Max(4nCK,3.7ns)	-	nCK		
ACTIVATE to ACTIVATE Command delay to different bank group for 1/2KB page size	tRRD_S(1/2K)	Max(4nCK,5ns)	-	Max(4nCK,4.2ns)	-	Max(4nCK,3.7ns)	-	nCK		
ACTIVATE to ACTIVATE Command delay to same bank group for 2KB page size	tRRD_L(2K)	Max(4nCK,7.5ns)	-	Max(4nCK,6.4ns)	-	Max(4nCK,6.4ns)	-	nCK		
ACTIVATE to ACTIVATE Command delay to same bank group for 1KB page size	tRRD_L(1K)	Max(4nCK,6ns)	-	Max(4nCK,5.3ns)	-	Max(4nCK,5.3ns)	-	nCK		
ACTIVATE to ACTIVATE Command delay to same bank group for 1/2KB page size	tRRD_L(1/2K)	Max(4nCK,6ns)	-	Max(4nCK,5.3ns)	-	Max(4nCK,5.3ns)	-	nCK		



Speed		DDR4-1600		DDR4-1866		DDR4-2133		Units	Note
Parameter	Symbol	MIN	MAX	MIN	MAX	MIN	MAX		
size									
Four activate window for 2KB page size	tFAW_2K	35		30		30		ns	
Four activate window for 1KB page size	tFAW_1K	25		23		21		ns	
Four activate window for 1KB page size	tFAW_1/2K	20		17		15		ns	
Delay from start of internal write transaction to internal read command for different bank group	tWTR_S	max(2nCK,2.5ns)	-	max(2nCK,2.5ns)	-	max(2nCK,2.5ns)	-		1,2,e
Delay from start of internal write transaction to internal read command for same bank group	tWTR_L	max(4nCK,7.5ns)	-	max(4nCK,7.5ns)	-	max(4nCK,7.5ns)	-		1
Internal READ Command to PRECHARGE Command delay	tRTP	max(4nCK,7.5ns)	-	max(4nCK,7.5ns)	-	max(4nCK,7.5ns)	-		
WRITE recovery time	tWR	15	-	15	-	15	-	ns	1
WRITE recovery time when CRC and DM are enabled	tWR_CRC_DM	tWR+max(4nCK,3.75ns)	-	tWR+max(5nCK,3.75ns)	-	tWR+max(5nCK,3.75ns)	-	ns	1,29
Delay from start of internal write transaction to internal read command for different bank groups with both CRC and OM enabled	tWTR_S_CRC_DM	tWTR_S+max(4nCK,3.75ns)	-	tWTR_S+max(5nCK,3.75ns)	-	tWTR_S+max(5nCK,3.75ns)	-	ns	2,30
Delay from start of internal write transaction to internal read command for same bank group with both CRC and OM enabled	tWTR_L_CRC_DM	tWTR_L+max(4nCK,3.75ns)	-	tWTR_L+max(5nCK,3.75ns)	-	tWTR_L+max(5nCK,3.75ns)	-	ns	3,31
DLL locking time	tDLLK	TBD						nCK	
Mode Register Set command cycle time	tMRD	8	-	8	-	8	-	nCK	
Mode Register Set command update delay	tMOD	max(24nCK,15ns)		max(24nCK,15ns)		max(24nCK,15ns)			
Multi-Purpose Register Recovery Time	tMPRR	1	-	1	-	1	-	nCK	
Multi-Purpose Register Write Recovery Time	tWR_MPR	tMOD (min)	-	tMOD (min)	-	tMOD (min)	-		
<b>CS_n to Command Address Latency</b>									
CS_n to Command Address Latency	tCAL	3	-	4	-	4	-	nCK	
<b>DRAM Data Timing</b>									
DQS_t,DQS_c to DQ skew, per group, per access	tDQSQ	-	tbd	-	tbd	-	tbd	tCK(avg)/2	14,1,9
DQS_t,DQS_c to DQ skew deterministic, per group, per access	tDQSQ	-	tbd	-	tbd	-	tbd	tCK(avg)/2	15,1,7,19
DQ output hold time from DQS_t,DQS_c	tQH	tbd	-	-	-	-	-	tCK(avg)/2	14,1,8,19
DQ output hold time deterministic from DQS_t,DQS_c	tQH	tbd	-	-	-	-	-	UI	15,1,7,19
DQS_t,DQS_c to DQ Skew total, per group, per access; DBI enabled	tDQSQ	-	tbd	-	tbd	-	tbd	UI	14,20
DQ output hold time total from DQS_t,DQS_c; DBI enabled	tQH	TBD	-	TBD	-	TBD	-	UI	14,20
DQ to DQ offset, per group, per access referenced to DQS_t,DQS_c	tDQSQ	TBD	TBD	TBD	TBD	TBD	TBD	UI	16,17
<b>Data Strobe Timing</b>									
DQS_t,DQS_c differential output high time	tQSH	TBD	TBD	TBD	TBD	TBD	TBD	tCK(avg)/2	22
DQS_t,DQS_c differential output low time	tQSL	TBD	TBD	TBD	TBD	TBD	TBD	tCK(avg)/2	21
<b>MPSM Timing</b>									
Command path disable delay upon MPSM entry	tMPED	tMOD(min) + tCPDED(min)	-	tMOD(min) + tCPDED(min)	-	tMOD(min) + tCPDED(min)	-		
Valid clock requirement after MPSM entry	tCKMPE	tMOD(min) + tCPDED(min)	-	tMOD(min) + tCPDED(min)	-	tMOD(min) + tCPDED(min)	-		
Valid clock requirement before MPSM exit	tCKMPX	tCKSRX(min)	-	tCKSRX(min)	-	tCKSRX(min)	-		
Exit MPSM to commands not requiring a locked DLL	tXMP	TBD	-	TBD	-	TBD	-		
Exit MPSM to commands requiring a locked DLL	tXMPDLL	tXMP(min) + tXSDLL(min)	-	tXMP(min) + tXSDLL(min)	-	tXMP(min) + tXSDLL(min)	-		
CS setup time to CKE	tMPX_S	TBD	-	TBD	-	TBD	-		
CS hold time to CKE	tMPX_H	TBD	-	TBD	-	TBD	-		

Speed		DDR4-1600		DDR4-1866		DDR4-2133		Units	Note
Parameter	Symbol	MIN	MAX	MIN	MAX	MIN	MAX		
<b>Calibration Timing</b>									
Power-up and RESET calibration time	tZQinit	1024	-	1024	-	1024	-	nCK	
Normal operation Full calibration time	tZQoper	512	-	512	-	512	-	nCK	
Normal operation Short calibration time	tZQCS	128	-	128	-	128	-	nCK	
<b>Reset/Self Refresh Timing</b>									
Exit Reset from CKE HIGH to a valid command	tXPR	max (5nCK,tRFC(min) + 10ns)	-	max (5nCK,tRFC(min) + 10ns)	-	max (5nCK,tRFC(min) + 10ns)	-		
Exit Self Refresh to commands not requiring a locked DLL	tXS	tRFC(min)+10ns	-	tRFC(min)+10ns	-	tRFC(min)+10ns	-		
SRX to commands not requiring a locked DLL in Self Refresh ABORT	tXS_ABORT(min)	tRFC4(min)+10ns	-	tRFC4(min)+10ns	-	tRFC4(min)+10ns	-		
Exit Self Refresh to ZQCL,ZQCS and MRS (CL,CWL,WR,RTP and Gear Down)	tXS_FAST (min)	tRFC4(min)+10ns	-	tRFC4(min)+10ns	-	tRFC4(min)+10ns	-		
Exit Self Refresh to commands requiring a locked DLL	tXSDLL	tDLLK(min)	-	tDLLK(min)	-	tDLLK(min)	-		
Minimum CKE low width for Self refresh entry to exit timing	tCKESR	tCKE(min)+1nCK	-	tCKE(min)+1nCK	-	tCKE(min)+1nCK	-		
Valid Clock Requirement after Self Refresh Entry (SRE) or Power-Down Entry (PDE)	tCKSRE	max(5nCK,10ns)	-	max(5nCK,10ns)	-	max(5nCK,10ns)	-		
Valid Clock Requirement after Self Refresh Entry (SRE) or Power-Down when CA Parity is enabled	tCKSRE_PAR	max (5nCK,10ns)+PL	-	max (5nCK,10ns)+PL	-	max (5nCK,10ns)+PL	-		
Valid Clock Requirement before Self Refresh Exit (SRX) or Power-Down Exit (PDX) or Reset Exit	tCKSRX	max(5nCK,10ns)	-	max(5nCK,10ns)	-	max(5nCK,10ns)	-		
<b>Power Down Timing</b>									
Exit Power Down with DLL on to any valid command; Exit Precharge Power Down with DLL frozen t commands not requiring a locked DLL	tXP	max (4nCK,6ns)	-	max (4nCK,6ns)	-	max (4nCK,6ns)	-		
Exit Precharge Power Down with DLL frozen to commands requiring a locked DLL	tXPDLL	max (10nCK, 24ns)	-	max (10nCK, 24ns)	-	max (10nCK, 24ns)	-		3
CKE minimum pulse width	tCKE	max (3nCK, 5ns)	-	max (3nCK, 5ns)	-	max (3nCK, 5ns)	-		32,33
Command pass disable delay	tCPDED	4	-	4	-	4	-		
Power Down Entry to Exit Timing	tPD	tCKE(min)	9*tREFI	tCKE(min)	9*tREFI	tCKE(min)	9*tREFI		6
Timing of ACT command to Power Down entry	tACTPDEN	1	-	1	-	2	-		7
Timing of PRE or PREA command to Power Down entry	tPRPDEN	1	-	1	-	2	-		7
Timing of RD/RDA command to Power Down entry	tRDPDEN	RL+4+1	-	RL+4+1	-	RL+4+1	-	nCK	
Timing of WR command to Power Down entry (BL8OTF, BL8MRS, BC4OTF)	tWRPDEN	WL+4+(tWR/ tCK(avg))	-	WL+4+(tWR/ tCK(avg))	-	WL+4+(tWR/ tCK(avg))	-	nCK	4
Timing of WRA command to Power Down entry (BL8OTF, BL8MRS, BC4OTF)	tWRAPDEN	WL+4+WR+1	-	WL+4+WR+1	-	WL+4+WR+1	-	nCK	5
Timing of WR command to Power Down entry (BC4MRS)	tWRPBC4DEN	WL+2+(tWR/ tCK(avg))	-	WL+2+(tWR/ tCK(avg))	-	WL+2+(tWR/ tCK(avg))	-	nCK	4
Timing of WRA command to Power Down entry (BC4MRS)	tWRAPBC4DEN	WL+2+WR+1	-	WL+2+WR+1	-	WL+2+WR+1	-	nCK	5
Timing of REF command to Power Down entry	tREFPDEN	1	-	1	-	2	-	nCK	7,8
Timing of MRS command to Power Down entry	tMRSPDEN	tMOD(min)	-	tMOD(min)	-	tMOD(min)	-		
<b>PDA Timing</b>									
Mode Register Set command cycle time in PDA mode	tMRD_PDA	max(16nCK,10ns)	-	max(16nCK,10ns)	-	max(16nCK,10ns)	-		
Mode Register Set command update delay in PDA mode	tMOD_PDA	tMOD		tMOD		tMOD			
<b>ODT Timing</b>									

Speed		DDR4-1600		DDR4-1866		DDR4-2133		Units	Note
Parameter	Symbol	MIN	MAX	MIN	MAX	MIN	MAX		
Asynchronous RTT turn-on delay (Power-Down with DLL frozen)	tAONAS	1	9	1	9	1	9	ns	
Asynchronous RTT turn-off delay (Power-Down with DLL frozen)	tAOFAS	1	9	1	9	1	9	ns	
RTT dynamic change skew	tADC	0.3	0.7	0.3	0.7	0.3	0.7	tCK(avg)	
<b>Write Leveling Timing</b>									
First DQS_t/DQS_n rising edge after write leveling mode is programmed	tWLMRD	40	-	40	-	40	-	nCK	13
DQS_t/DQS_n delay after write leveling mode is programmed	tWLDQSEN	25	-	25	-	25	-	nCK	13
Write leveling setup time from rising CK_t, CK_c crossing to rising DQS_t/DQS_n crossing	tWLS	0.13	-	0.13	-	0.13	-	tCK(avg)	
Write leveling hold time from rising DQS_t/DQS_n crossing to rising CK_t, CK_c crossing	tWLH	0.13	-	0.13	-	0.13	-	tCK(avg)	
Write leveling output delay	tWLO	0	9.5	0	9.5	0	9.5	ns	
Write leveling output error	tWLOE							ns	
<b>CA Parity Timing</b>									
Commands not guaranteed to be executed during this time	tPAR_UNKNOWN	-	Max(2nCK,3ns)	-	Max(2nCK,3ns)	-	Max(2nCK,3ns)		
Delay from errant command to ALERT_n assertion	tPAR_ALERT_ON	-	PL+6ns	-	PL+6ns	-	PL+6ns		
Pulse width of ALERT_n signal when asserted	tPAR_ALERT_PW	48	96	56	112	64	128	nCK	
Time from when Alert is asserted till controller must start providing DES commands in Persistent CA parity mode	tPAR_ALERT_RSP	-	43	-	50	-	57	nCK	
Parity Latency [ 1715.64, JC42.3C]	PL	4		4		4		nCK	
<b>CRC Error Reporting</b>									
CRC error to ALERT_n latency	tCRC_ALERT	-	13	-	13	-	13	ns	
CRC ALERT_n pulse width	CRC_ALERT_PW	6	10	6	10	6	10	nCK	
Write recovery time when CRC and DM are enabled	tWR_CRC_DM	tWR+max (4nCK,3.75ns)	-	tWR+max (5nCK,3.75ns)	-	tWR+max (5nCK,3.75ns)	-	ns	10
delay from start of internal write transaction to internal delay from start of internal write transaction to internal read command for different bank group with both CRC and DM enabled	tWTR_S_C RC_DM	tWTR_S+max (4nCK,3.75ns)	-	tWTR_S+max (5nCK,3.75ns)	-	tWTR_S+max (5nCK,3.75ns)	-	ns	11
delay from start of internal write transaction to internal delay from start of internal write transaction to internal read command for same bank group with both CRC and DM enabled	tWTR_L_C RC_DM	tWTR_L+max (4nCK,3.75ns)	-	tWTR_L+max (5nCK,3.75ns)	-	tWTR_L+max (5nCK,3.75ns)	-	ns	12
<b>Geardown timing</b>									
Exit RESET from CKE HIGH to a valid MRS geardown (T2/Reset)	tXPR_GEAR	tXPR		tXPR					
CKE HIGH Assert Geardown Enable time(T2/CKE)	tXS_GEAR	tXS		tXS					
MRS command to Sync pulse time(T3)	tSYNC_GEAR	tMOD(min)+4nCK		tMOD(min)+4nCK					28
Sync pulse to First valid command(T4)	tCMD_GEAR								28
Geardown setup time	tGEAR_setup							nCK	
Geardown hold time	tGEAR_hold							nCK	
<b>tREFI</b>									
tRFC1 (min)	2Gb	160	-	160	-	160	-	ns	
	4Gb	260	-	260	-	260	-	ns	
	8Gb	350	-	350	-	350	-	ns	
	16Gb	TBD by JEDEC board spec)	-	TBD	-	TBD	-	ns	
tRFC2 (min)	2Gb	110	-	110	-	110	-	ns	
	4Gb	160	-	160	-	160	-	ns	
	8Gb	260	-	260	-	260	-	ns	
	16Gb	TBD by JEDEC board spec)	-	TBD	-	TBD	-	ns	
tRFC4 (min)	2Gb	90	-	90	-	90	-	ns	

Speed		DDR4-1600		DDR4-1866		DDR4-2133		Units	Note
Parameter	Symbol	MIN	MAX	MIN	MAX	MIN	MAX		
	4Gb	110	-	110	-	110	-	ns	
	8Gb	160	-	160	-	160	-	ns	
	16Gb	TBD by JEDEC board spec)	-	TBD	-	TBD	-	ns	

## Timing Parameters by Speed Grade, continued

Speed		DDR4-2400		DDR4-2667		DDR4-3200		Units	Note
Parameter	Symbol	MIN	MAX	MIN	MAX	MIN	MAX		
<b>Clock Timing</b>									
Minimum Clock Cycle Time (DLL off mode)	tCK(DLL_OFF)	8	-	8	-	8	-	ns	23
Average Clock Period	tCK(avg)	See Speed Bins Table						ps	
Average high pulse width	tCH(avg)	0.48	0.52	0.48	0.52	0.48	0.52	tCK(avg)	
Average low pulse width	tCL(avg)	0.48	0.52	0.48	0.52	0.48	0.52	tCK(avg)	
Absolute Clock Period	tCK(abs)	tCK(avg)min + tJIT(per)min_tot	tCK(avg)max + tJIT(per)max_tot	tCK(avg)min + tJIT(per)min_tot	tCK(avg)max + tJIT(per)max_tot	tCK(avg)min + tJIT(per)min_tot	tCK(avg)max + tJIT(per)max_tot	tCK	
Absolute clock HIGH pulse width	tCH(abs)	0.45	-	0.45	-	0.45	-	tCK(avg)	24
Absolute clock Low pulse width	tCL(abs)	0.45	-	0.45	-	0.45	-	tCK(avg)	25
Clock Period Jitter- total	JIT(per)_tot	-42	42	-0.1	0.1	-0.1	0.1	UI	26
Clock Period Jitter- deterministic	JIT(per)_dj	tbd						UI	27
Clock Period Jitter during DLL locking period	tJIT(per, lck)	tbd						UI	
Cycle to Cycle Period Jitter	tJIT(cc)_tot	83		0.2		0.2		UI	26
Cycle to Cycle Period Jitter- deterministic	tJIT(cc)_dj	tbd						UI	27
Cycle to Cycle Period Jitter during DLL locking period	tJIT(cc, lck)	tbd						UI	
Duty cycle Jitter	tJIT(duty)	tbd						UI	
Cumulative error across 2 cycles	tERR(2per)	tbd						UI	
Cumulative error across 3 cycles	tERR(3per)	tbd						UI	
Cumulative error across 4 cycles	tERR(4per)	tbd						UI	
Cumulative error across 5 cycles	tERR(5per)	tbd						UI	
Cumulative error across 6 cycles	tERR(6per)	tbd						UI	
Cumulative error across 7 cycles	tERR(7per)	tbd						UI	
Cumulative error across 8 cycles	tERR(8per)	tbd						UI	
Cumulative error across 9 cycles	tERR(9per)	tbd						UI	
Cumulative error across 10 cycles	tERR(10per)	tbd						UI	
Cumulative error across 11 cycles	tERR(11per)	tbd						UI	
Cumulative error across 12 cycles	tERR(12per)	tbd						UI	
Cumulative error across n = 13, 14 ... 49, 50 cycles	tERR(nper)	tbd						UI	
<b>Command and Address Timing</b>									
CAS_n to CAS_n command delay for same bank group	tCCD_L	6	-	tbd	-	-	-	nCK	
CAS_n to CAS_n command delay for different bank group	tCCD_S	4	-	4	-	-	-	nCK	
ACTIVATE to ACTIVATE Command delay to different bank group for 2KB page size	tRRD_S(2K)	Max(4nCK, 5.3ns)	-		-	-	-	nCK	
ACTIVATE to ACTIVATE Command delay to different bank group for 1KB page size	tRRD_S(1K)	Max(4nCK, 3.3ns)	-		-	-	-	nCK	
ACTIVATE to ACTIVATE Command delay to different bank group for 1/2KB page size	tRRD_S(1/2K)	Max(4nCK, 3.3ns)	-		-	-	-	nCK	
ACTIVATE to ACTIVATE Command delay to same bank group for 2KB page size	tRRD_L(2K)	Max(4nCK, 6.4ns)	-		-	-	-	nCK	
ACTIVATE to ACTIVATE Command delay to same bank group for 1KB page size	tRRD_L(1K)	Max(4nCK, 4.9ns)	-		-	-	-	nCK	
ACTIVATE to ACTIVATE Command delay to same bank group for 1/2KB page size	tRRD_L(1/2K)	Max(4nCK, 4.9ns)	-		-	-	-	nCK	
Four activate window for 2KB page size	tFAW_2K	30						ns	

Speed		DDR4-2400		DDR4-2667		DDR4-3200		Units	Note
Parameter	Symbol	MIN	MAX	MIN	MAX	MIN	MAX		
Four activate window for 1KB page size	tFAW_1K	21						ns	
Four activate window for 1KB page size	tFAW_1/2K	13						ns	
Delay from start of internal write transaction to internal read command for different bank group	tWTR_S	max(2nCK,2.5ns)	-		-		-		1,2,e
Delay from start of internal write transaction to internal read command for same bank group	tWTR_L	max(4nCK,7.5ns)	-		-		-		1
Internal READ Command to PRECHARGE Command delay	tRTP	max (4nCK,7.5ns)	-		-		-		
WRITE recovery time	tWR	15	-		-		-	ns	1
WRITE recovery time when CRC and DM are enabled	tWR_CRC_DM	tWR+max(5nCK,3.75ns)	-		-		-	ns	1,29
Delay from start of internal write transaction to internal read command for different bank groups with both CRC and OM enabled	tWTR_S_CRC_DM	tWTR_S+max(5nCK,3.75ns)	-		-		-	ns	2,30
Delay from start of internal write transaction to internal read command for same bank group with both CRC and OM enabled	tWTR_L_CRC_DM	tWTR_L+max(5nCK,3.75ns)	-		-		-	ns	3,31
DLL locking time	tDLLK	TBD						nCK	
Mode Register Set command cycle time	tMRD	8	-		-		-	nCK	
Mode Register Set command update delay	tMOD	max(24nCK,15ns)	-		-		-		
Multi-Purpose Register Recovery Time	tMPRR	1	-		-		-	nCK	
Multi-Purpose Register Write Recovery Time	tWR_MPR	tMOD (min) + AL + PL	-		-		-		
<b>CS_n to Command Address Latency</b>									
CS_n to Command Address Latency	tCAL	5	-		-		-	nCK	
<b>DRAM Data Timing</b>									
DQS_t,DQS_c to DQ skew, per group, per access	tDQSQ	-	tbd	-	tbd	-	tbd	tCK(avg)/2	14,1,9
DQS_t,DQS_c to DQ skew deterministic, per group, per access	tDQSQ	-	tbd	-	tbd	-	tbd	tCK(avg)/2	15,1,7,19
DQ output hold time from DQS_t,DQS_c	tQH	tbd	-		-		-	tCK(avg)/2	14,1,8,19
DQ output hold time deterministic from DQS_t, DQS_c	tQH	tbd	-		-		-	UI	15,1,7,19
DQS_t,DQS_c to DQ Skew total, per group, per access; DBI enabled	tDQSQ	-	tbd	-	tbd	-	tbd	UI	14,20
DQ output hold time total from DQS_t, DQS_c; DBI enabled	tQH	TBD	-	TBD	-	TBD	-	UI	14,20
DQ to DQ offset , per group, per access refer-enced to DQS_t, DQS_c	tDQSQ	TBD	TBD	TBD	TBD	TBD	TBD	UI	16, 17
<b>Data Strobe Timing</b>									
DQS_t,DQS_c differential output high time	tQSH	TBD	TBD	TBD	TBD	TBD	TBD	tCK(avg)/2	22
DQS_t,DQS_c differential output low time	tQSL	TBD	TBD	TBD	TBD	TBD	TBD	tCK(avg)/2	21
<b>MPSM Timing</b>									
Command path disable delay upon MPSM entry	tMPED	tMOD(min) + tCPDED(min)	-				-		
Valid clock requirement after MPSM entry	tCKMPE	tMOD(min) + tCPDED(min)	-				-		
Valid clock requirement before MPSM exit	tCKMPX	tCKSRX(min)	-				-		
Exit MPSM to commands not requiring a locked DLL	tXMP	TBD	-				-		
Exit MPSM to commands requiring a locked DLL	tXMPDLL	tXMP(min) + tXSDDL(min)	-				-		
CS setup time to CKE	tMPX_S	TBD	-				-		
CS hold time to CKE	tMPX_H	TBD	-				-		
<b>Calibration Timing</b>									
Power-up and RESET calibration time	tZQinit	1024	-				-	nCK	
Normal operation Full calibration time	tZQoper	512	-				-	nCK	

Speed		DDR4-2400		DDR4-2667		DDR4-3200		Units	Note
Parameter	Symbol	MIN	MAX	MIN	MAX	MIN	MAX		
Normal operation Short calibration time	tZQCS	128	-				-	nCK	
<b>Reset/Self Refresh Timing</b>									
Exit Reset from CKE HIGH to a valid command	tXPR	max(5nCK,tRFC(min)+10ns)	-				-		
Exit Self Refresh to commands not requiring a locked DLL	tXS	tRFC(min)+10ns	-				-		
SRX to commands not requiring a locked DLL in Self Refresh ABORT	tXS_ABORT(min)	tRFC4(min)+10ns	-				-		
Exit Self Refresh to ZQCL,ZQCS and MRS (CL,CWL,WR,RTP and Gear Down)	tXS_FAST (min)	tRFC4(min)+10ns	-				-		
Exit Self Refresh to commands requiring a locked DLL	tXSDLL	tDLL(min)	-				-		
Minimum CKE low width for Self refresh entry to exit timing	tCKESR	tCKE(min)+1nCK	-				-		
Valid Clock Requirement after Self Refresh Entry (SRE) or Power-Down Entry (PDE)	tCKSRE	max(5nCK,10ns)	-				-		
Valid Clock Requirement after Self Refresh Entry (SRE) or Power-Down when CA Parity is enabled	tCKSRE_PAR	max(5nCK,10ns)+PL	-				-		
Valid Clock Requirement before Self Refresh Exit (SRX) or Power-Down Exit (PDX) or Reset Exit	tCKSRX	max(5nCK,10ns)	-				-		
<b>Power Down Timing</b>									
Exit Power Down with DLL on to any valid command; Exit Precharge Power Down with DLL frozen t commands not requiring a locked DLL	tXP	max(4nCK,6ns)	-				-		
Exit Precharge Power Down with DLL frozen to commands requiring a locked DLL	tXPDLL	max(10nCK,24ns)	-				-		3
CKE minimum pulse width	tCKE	max(3nCK,5ns)	-				-		32,33
Command pass disable delay	tCPDED	4	-				-		
Power Down Entry to Exit Timing	tPD	tCKE(min)	9*tREFI				9*tREFI		6
Timing of ACT command to Power Down entry	tACTPDEN	2	-				-		7
Timing of PRE or PREA command to Power Down entry	tPRPDEN	2	-				-		7
Timing of RD/RDA command to Power Down entry	tRDPDEN	RL+4+1	-				-	nCK	
Timing of WR command to Power Down entry (BL8OTF, BL8MRS, BC4OTF)	tWRPDEN	WL+4+(tWR/ tCK(avg))	-				-	nCK	4
Timing of WRA command to Power Down entry (BL8OTF, BL8MRS, BC4OTF)	tWRAPDEN	WL+4+WR+1	-				-	nCK	5
Timing of WR command to Power Down entry (BC4MRS)	tWRPBC4DEN	WL+2+(tWR/ tCK(avg))	-				-	nCK	4
Timing of WRA command to Power Down entry (BC4MRS)	tWRAPBC4DEN	WL+2+WR+1	-				-	nCK	5
Timing of REF command to Power Down entry	tREFPDEN	2	-				-	nCK	7,8
Timing of MRS command to Power Down entry	tMRSPDEN	tMOD(min)	-				-		
<b>PDA Timing</b>									
Mode Register Set command cycle time in PDA mode	tMRD_PDA	max(16nCK,10ns)	-	max(16nCK,10ns)	-	max(16nCK,10ns)	-		
Mode Register Set command update delay in PDA mode	tMOD_PDA	tMOD		tMOD		tMOD			
<b>ODT Timing</b>									
Asynchronous RTT turn-on delay (Power-Down with DLL frozen)	tAONAS	1	9					ns	
Asynchronous RTT turn-off delay (Power-Down with DLL frozen)	tAOFAS	1	9					ns	
RTT dynamic change skew	tADC	0.3	0.7					tCK(avg)	
<b>Write Leveling Timing</b>									
First DQS_t/DQS_n rising edge after write leveling mode is programmed	tWLMRD	40	-					nCK	13
DQS_t/DQS_n delay after write leveling mode is programmed	tWLDQSEN	25	-					nCK	13

Speed		DDR4-2400		DDR4-2667		DDR4-3200		Units	Note
Parameter	Symbol	MIN	MAX	MIN	MAX	MIN	MAX		
Write leveling setup time from rising CK <sub>t</sub> , CK <sub>c</sub> crossing to rising DQS, t/DQS <sub>n</sub> crossing	tWLS	0.13	-					tCK(avg)	
Write leveling hold time from rising DQS, t/DQS <sub>n</sub> crossing to rising CK <sub>t</sub> , CK <sub>c</sub> crossing	tWLH	0.13	-					tCK(avg)	
Write leveling output delay	tWLO	0	9.5					ns	
Write leveling output error	tWLOE							ns	
<b>CA Parity Timing</b>									
Commands not guaranteed to be executed during this time	tPAR_UNKNOWN	-	Max(2nCK,3ns)						
Delay from errant command to ALERT <sub>n</sub> assertion	tPAR_ALERT_ON	-	PL+6ns						
Pulse width of ALERT <sub>n</sub> signal when asserted	tPAR_ALERT_PW	72	144					nCK	
Time from when Alert is asserted till controller must start providing DES commands in Persistent CA parity mode	tPAR_ALERT_RSP	-	64					nCK	
Parity Latency [ 1715.64, JC42.3C]	PL	5						nCK	
<b>CRC Error Reporting</b>									
CRC error to ALERT <sub>n</sub> latency	tCRC_ALERT	-	13					ns	
CRC ALERT <sub>n</sub> pulse width	CRC_ALERT_PW	6	10					nCK	
Write recovery time when CRC and DM are enabled	tWR_CRC_DM	tWR+max (5nCK,3.75ns)						ns	10
delay from start of internal write transaction to internal delay from start of internal write transaction to internal read command for different bank group with both CRC and DM enabled	tWTR_S_C RC_DM	tWTR_S+max (5nCK,3.75ns)						ns	11
delay from start of internal write transaction to internal delay from start of internal write transaction to internal read command for same bank group with both CRC and DM enabled	tWTR_L_C RC_DM	tWTR_L+max (5nCK,3.75ns)						ns	12
<b>Geardown timing</b>									
Exit RESET from CKE HIGH to a valid MRS geardown (T2/Reset)	tXPR_GEAR	tXPR		tXPR					
CKE HIGH Assert Geardown Enable time(T2/CKE)	tXS_GEAR	tXS		tXS					
MRS command to Sync pulse time(T3)	tSYNC_GEAR	tMOD(min)+4nCK		tMOD(min)+4nCK					28
Sync pulse to First valid command(T4)	tCMD_GEAR			tMOD		tMOD			28
Geardown setup time	tGEAR_setup			2	-	2	-	nCK	
Geardown hold time	tGEAR_hold			2	-	2	-	nCK	
<b>tREFI</b>									
tRFC1 (min)	2Gb	160	-	160	-	160	-	ns	
	4Gb	260	-	260	-	260	-	ns	
	8Gb	350	-	350	-	350	-	ns	
	16Gb	TBD by JEDEC board spec)	-	TBD	-	TBD	-	ns	
tRFC2 (min)	2Gb	110	-	110	-	110	-	ns	
	4Gb	160	-	160	-	160	-	ns	
	8Gb	260	-	260	-	260	-	ns	
	16Gb	TBD by JEDEC board spec)	-	TBD	-	TBD	-	ns	
tRFC4 (min)	2Gb	90	-	90	-	90	-	ns	
	4Gb	110	-	110	-	110	-	ns	
	8Gb	160	-	160	-	160	-	ns	
	16Gb	TBD by JEDEC board spec)	-	TBD	-	TBD	-	ns	

**Notes:**

- Start of internal write transaction is defined as follows:  
 For BL8 (Fixed by MRS and on-the-fly): Rising clock edge 4 clock cycles after WL.  
 For BC4 (on-the-fly): Rising clock edge 4 clock cycles after WL.  
 For BC4 (fixed by MRS): Rising clock edge 2 clock cycles after WL.
- A separate timing parameter will cover the delay from write to read when CRC and DM are simultaneously enabled
- Commands requiring a locked DLL are: READ (and RAP) and synchronous ODT commands.
- tWR is defined in ns, for calculation of tWRPDEN it is necessary to round up tWR/tCK to the next integer.
- WR in clock cycles as programmed in MR0.
- tREFI depends on TOPER.
- CKE is allowed to be registered low while operations such as row activation, precharge, autoprecharge or refresh are in progress, but power-down IDD spec will not be applied until finishing those operations.
- Although CKE is allowed to be registered LOW after a REFRESH command once tREFPDEN(min) is satisfied, there are cases where additional time such as tXPDLL(min) is also required. See 0.1.3 "Power-Down clarifications - Case 2" in RB11112 .

Datasheet	5/11/2017
PS9FUxx64x8xxx_VP	Viking Technology
Revision B	Page 40 of 41



- DQ Receiver(Rx) compliance mask
- 9. For these parameters, the DDR4 SDRAM device supports  $t_{nPARAM}[nCK]=RU\{t_{PARAM}[ns]/t_{CK}(avg)[ns]\}$ , which is in clock cycles assuming all input clock jitter specifications are satisfied
- 10. When CRC and DM are both enabled,  $t_{WR\_CRC\_DM}$  is used in place of  $t_{WR}$ .
- 11. When CRC and DM are both enabled  $t_{WTR\_S\_CRC\_DM}$  is used in place of  $t_{WTR\_S}$ .
- 12. When CRC and DM are both enabled  $t_{WTR\_L\_CRC\_DM}$  is used in place of  $t_{WTR\_L}$ .
- 13. The max values are system dependent.
- 14. DQ to DQS total timing per group where the total includes the sum of deterministic and random timing terms for a specified BER. BER spec and measurement method are tbd.
- 15. The deterministic component of the total timing. Measurement method tbd.
- 16. DQ to DQ static offset relative to strobe per group. Measurement method tbd.
- 17. This parameter will be characterized and guaranteed by design.
- 18. When the device is operated with the input clock jitter, this parameter needs to be derated by the actual  $t_{jit}(per)_{total}$  of the input clock. (output Deratings are relative to the SDRAM input clock). Example tbd.
- 19. DRAM DBI mode is off.
- 20. DRAM DBI mode is enabled. Applicable to x8 and x16 DRAM only.
- 21.  $t_{QSL}$  describes the instantaneous differential output low pulse width on  $DQS\_t - DQS\_c$ , as measured from on falling edge to the next consecutive rising edge
- 22.  $t_{QSH}$  describes the instantaneous differential output high pulse width on  $DQS\_t - DQS\_c$ , as measured from on falling edge to the next consecutive rising edge
- 23. There is no maximum cycle time limit besides the need to satisfy the refresh interval  $t_{REFI}$
- 24.  $t_{CH}(abs)$  is the absolute instantaneous clock high pulse width, as measured from one rising edge to the following falling edge
- 25.  $t_{CL}(abs)$  is the absolute instantaneous clock low pulse width, as measured from one falling edge to the following rising edge
- 26. Total jitter includes the sum of deterministic and random jitter terms for a specified BER. BER target and measurement method are tbd.
- 27. The deterministic jitter component out of the total jitter. This parameter is characterized and guaranteed by design.
- 28. This parameter has to be even number of clocks
- 29. When CRC and DM are both enabled,  $t_{WR\_CRC\_DM}$  is used in place of  $t_{WR}$ .
- 30. When CRC and DM are both enabled  $t_{WTR\_S\_CRC\_DM}$  is used in place of  $t_{WTR\_S}$ .
- 31. When CRC and DM are both enabled  $t_{WTR\_L\_CRC\_DM}$  is used in place of  $t_{WTR\_L}$ .
- 32. After CKE is registered LOW, CKE signal level shall be maintained below  $V_{ILDC}$  for  $t_{CKE}$  specification ( Low pulse width).
- 33. After CKE is registered HIGH, CKE signal level shall be maintained above  $V_{IHDC}$  for  $t_{CKE}$  specification ( HIGH pulse width).  
 $UI=t_{CK}(avg).min/2$

Datasheet	5/11/2017
PS9FUxx64x8xxx_VP	Viking Technology
Revision B	Page 41 of 41