

# DDR4 NON-ECC UDIMM VR9MUxx64x8xxx

The Viking DDR4 UDIMM memory module offers lower operating voltages, higher module densities and faster speed categories than the prior DDR3 generation. JEDEC DDR4 (JESD79-4) has been defined to provide higher performance, with improved reliability and reduced power, thereby representing a significant achievement relative to previous DRAM memory technologies.

Datasheet	11/28/2017
PS9MUxx64x8xxx	Viking Technology
Revision C	Page 1 of 41

## REVISION HISTORY

Revision	Release Date	Description of Change	Checked By (Full Name)
A	6/16/15	Initial Release	IDC
B	5/11/17	Revise logo and color scheme. Change company address	
C	11/28/17	Add DDR4-2666 Speed Bins and PN's	

Datasheet	11/28/2017
PS9MUxx64x8xxx	Viking Technology
Revision C	Page 2 of 41

## Legal Information

### Legal Information

Copyright© 2017 Sanmina Corporation. All rights reserved. The information in this document is proprietary and confidential to Sanmina Corporation. No part of this document may be reproduced in any form or by any means or used to make any derivative work (such as translation, transformation, or adaptation) without written permission from Sanmina. Sanmina reserves the right to revise this documentation and to make changes in content from time to time without obligation on the part of Sanmina to provide notification of such revision or change.

Sanmina provides this documentation without warranty, term or condition of any kind, either expressed or implied, including, but not limited to, expressed and implied warranties of merchantability, fitness for a particular purpose, and non-infringement. While the information contained herein is believed to be accurate, such information is preliminary, and should not be relied upon for accuracy or completeness, and no representations or warranties of accuracy or completeness are made. In no event will Sanmina be liable for damages arising directly or indirectly from any use of or reliance upon the information contained in this document. Sanmina may make improvements or changes in the product(s) and/or the program(s) described in this documentation at any time.

Sanmina, Viking Technology, Viking Modular Solutions, and the Viking logo are trademarks of Sanmina Corporation. Other company, product or service names mentioned herein may be trademarks or service marks of their respective owners.

### STATEMENT OF COMPLIANCE

Viking Technology, Sanmina Corporation ("Viking") shall use commercially reasonable efforts to provide components, parts, materials, products and processes to Customer that do not contain: (i) lead, mercury, hexavalent chromium, polybrominated biphenyls (PBB) and polybrominated diphenyl ethers (PBDE) above 0.1% by weight in homogeneous material or (ii) cadmium above 0.01% by weight of homogeneous material, except as provided in any exemption(s) from RoHS requirements (including the most current version of the "Annex" to Directive 2002/95/EC of 27 January, 2003), as codified in the specific laws of the EU member countries. Viking strives to obtain appropriate contractual protections from its suppliers in connection with the RoHS Directives.

All printed circuit boards (PCBs) have a flammability rating of UL94V-0.

Datasheet	11/28/2017
PS9MUxx64x8xxx	Viking Technology
Revision C	Page 3 of 41

## 288 pin Ordering Information and Module Configuration

Viking Part Number	Voltage	Capacity	Module Configuration	Device Configuration	Device Package	Ranks	Speed	CAS Latency
VR9MU126428HBGyz	1.2V	4GB	512Mx64	512Mx8 (8)	4Gb FBGA	1	DDR4-14900	CL13 (13-13-13)
VR9MU126428HBHyz	1.2V	4GB	512Mx64	512Mx8 (8)	4Gb FBGA	1	DDR4-17000	CL15 (15-15-15)
VR9MU126428HBJyz <sup>1</sup>	1.2V	4GB	512Mx64	512Mx8 (8)	4Gb FBGA	1	DDR4-19200	CL17 (17-17-17)
VR9MU126428HBKyz <sup>1</sup>	1.2V	4GB	512Mx64	512Mx8 (8)	4Gb FBGA	1	DDR4-21300	CL19 (19-19-19)
VR9MU1G6428HBGyz	1.2V	8GB	1Gx64	512Mx8 (16)	4Gb FBGA	2	DDR4-14900	CL13 (13-13-13)
VR9MU1G6428HBHyz	1.2V	8GB	1Gx64	512Mx8 (16)	4Gb FBGA	2	DDR4-17000	CL15 (15-15-15)
VR9MU1G6428HBJyz <sup>1</sup>	1.2V	8GB	1Gx64	512Mx8 (16)	4Gb FBGA	2	DDR4-19200	CL17 (17-17-17)
VR9MU1G6428HBKyz <sup>1</sup>	1.2V	8GB	1Gx64	512Mx8 (16)	4Gb FBGA	2	DDR4-21300	CL19 (19-19-19)
VR9MU1G6428JBGyz <sup>1</sup>	1.2V	8GB	1Gx64	1024Mx8 (8)	8Gb FBGA	1	DDR4-14900	CL13 (13-13-13)
VR9MU1G6428JBHyz <sup>1</sup>	1.2V	8GB	1Gx64	1024Mx8 (8)	8Gb FBGA	1	DDR4-17000	CL15 (15-15-15)
VR9MU1G6428JBJyz <sup>1</sup>	1.2V	8GB	1Gx64	1024Mx8 (8)	8Gb FBGA	1	DDR4-19200	CL17 (17-17-17)
VR9MU1G6428JBKyz <sup>1</sup>	1.2V	8GB	1Gx64	1024Mx8 (8)	8Gb FBGA	1	DDR4-21300	CL19 (19-19-19)
VR9MU2G6428JBGyz <sup>1</sup>	1.2V	16GB	2Gx64	1024Mx8 (16)	8Gb FBGA	2	DDR4-14900	CL13 (13-13-13)
VR9MU2G6428JBHyz <sup>1</sup>	1.2V	16GB	2Gx64	1024Mx8 (16)	8Gb FBGA	2	DDR4-17000	CL15 (15-15-15)
VR9MU2G6428JBJyz <sup>1</sup>	1.2V	16GB	2Gx64	1024Mx8 (16)	8Gb FBGA	2	DDR4-19200	CL17 (17-17-17)
VR9MU2G6428JBKyz <sup>1</sup>	1.2V	16GB	2Gx64	1024Mx8 (16)	8Gb FBGA	2	DDR4-21300	CL19 (19-19-19)

**Notes:**

- For part numbers containing a lowercase x, contact Viking for the full PN.
- The lowercase letters y and z are wildcard characters that indicate DRAM vendor and die revisions and /or for customer specific locked BOMs. Refer to the Viking part number coversheet for details.

Datasheet	11/28/2017
PS9MUxx64x8xxx	Viking Technology
Revision C	Page 4 of 41

## Features

- JEDEC Standard Power Supply
  - VDD = VDDQ = 1.2V± 5% (1.14V-1.26V)
  - External VPP = 2.5 Volt +10%, -5%
  - VDDSPD = 2.2 to 2.8 Volts
- 260 pin Small Outline Dual-In-Line Memory Module
- Edge finger connector ramp zone to reduce insertion force
- Point-to-Point topology to reduce loading
- Pseudo-open drain (POD12) DQ lines
- Internally generated VrefDQ
- On-chip CA Parity detection for the command/address bus
- Programmable CAS Latency: 13, 15,17,19
- Programmable CAS Write Latency (CWL).
- Programmable Additive Latency (Posted CAS)
- Per DRAM addressability is supported
- Data Bus Inversion support for x8 devices
- Selectable Fixed burst chop (BC4) of 4 and burst length (BL8) of 8 on-the-fly (OTF) via the mode register set (MRS)
- 8n prefetch with 2 or 4 selectable bank groups: 16 banks (4 bank groups x 4 banks per bank group)
- Separate activation, read, write, refresh operations for each bank group
- 7 mode registers
- Dynamic On-Die-Termination (ODT) and ODT Park for improved signal integrity.
- Self Refresh and several Power Down Modes
- DLL-off mode for power savings
- System Level Timing Calibration Support via Write Leveling and Multi Purpose Register (MPR) Read Pattern
- Serial Presence Detect with EEPROM
- Two On-DIMM Thermal Sensors
- Asynchronous Reset
- Bidirectional Differentially Buffered Data Strokes(DQS)
- UDIMM dimensions per JEDEC MO-309 maximum limits
- RoHS Compliant

## DDR4 SPEED BIN Nomenclature

Module Standard	SDRAM Standard	Clock
DDR4-14900	DDR4-1866	933 MHz
DDR4-17000	DDR4-2133	1066 MHz
DDR4-19200	DDR4-2400	1200 MHz
DDR4-21300	DDR4-2667	1333 MHz
DDR4-25600 <sup>1</sup>	DDR4-3200	1600 MHz

### Notes:

1. Contact Viking for availability date

## DDR4 Timing Summary

MT/s	tCK (ns)	CAS Latency (tCK)	tRCD (ns)	tRP (ns)	tRAS (ns)	tRC (ns)	CL-tRCD-tRP
<b>DDR4-1866</b>	1.071	13	13.92	13.92	34	47.92	13-13-13
<b>DDR4-2133</b>	0.93	15	14.06	14.06	33	47.05	15-15-15
<b>DDR4-2400</b>	0.83	17	14.16	14.16	32	46.16	17-17-17
<b>DDR4-2666</b>	0.75	19	14.25	14.25	32	46.25	19-19-19

### Notes:

- CL = CAS Latency, tRCD = Activate –to-Command Time, tRP = Precharge Time. Refer to Speed Bin tables for details.

Datasheet	11/28/2017
PS9MUxx64x8xxx	Viking Technology
Revision C	Page 5 of 41

## Addressing

		4GB(1Rx8) 512Mx8 DRAM	8GB(1Rx8) 1024Mx8 DRAM	16GB(2Rx8) 1024Mx8 DRAM
Bank Address	# of Bank Groups	4	4	4
	BG Address	BG0~BG1	BG0~BG1	BG0~BG1
	Bank Address in a BG	BA0~BA1	BA0~BA1	BA0~BA1
Row Address		A0~A14	64K:A0~A15	64K:A0~A15
Column Address		A0~ A9	A0~ A9	A0~ A9
Page size		512B	512B	512B
Refresh Count		4K	8K	8K

**Note:**

- Micron datasheet specified 512B / 1KB as page size with "Die revision dependant".
- In Hynix and Samsung Datasheet specifies 512B for x4 Device.

Datasheet	11/28/2017
PS9MUxx64x8xxx	Viking Technology
Revision C	Page 6 of 41

## DDR4 288-pin UDIMM Pin Wiring Assignments/Configurations

Pin#	Description	Pin#	Description	Pin#	Description	Pin#	Description	Pin#	Description	Pin#	Description
1	12V <sup>3</sup> , NC	145	12V <sup>3</sup> , NC	52	DQS17_c, TDQS17_c	196	DQS8_c	102	DQ38	246	VSS
2	VSS	146	VREFCA	53	VSS	197	DQS8_t	103	VSS	247	DQ39
3	DQ4	147	VSS	54	CB6, NC	198	VSS	104	DQ34	248	VSS
4	VSS	148	DQ5	55	VSS	199	CB7, NC	105	VSS	249	DQ35
5	DQ0	149	VSS	56	CB2, NC	200	VSS	106	DQ44	250	VSS
6	VSS	150	DQ1	57	VSS	201	CB3, NC	107	VSS	251	DQ45
7	DQS9_t, DM0_n, DBI0_n, TDQS9_t	151	VSS	58	RESET_n	202	VSS	108	DQ40	252	VSS
8	DQS9_c, TDQS9_c	152	DQS0_c	59	VDD	203	CKE1	109	VSS	253	DQ41
9	VSS	153	DQS0_t	60	CKE0	204	VDD	110	DQS14_t, DM5_n, DBI5_n, TDQS14_t	254	VSS
10	DQ6	154	VSS	61	VDD	205	RFU	111	DQS14_c, TDQS14_c	255	DQS5_c
11	VSS	155	DQ7	62	ACT_n	206	VDD	112	VSS	256	DQS5_t
12	DQ2	156	VSS	63	BG0	207	BG1	113	DQ46	257	VSS
13	VSS	157	DQ3	64	VDD	208	ALERT_n	114	VSS	258	DQ47
14	DQ12	158	VSS	65	A12	209	VDD	115	DQ42	259	VSS
15	VSS	159	DQ13	66	A9	210	A11	116	VSS	260	DQ43
16	DQ8	160	VSS	67	VDD	211	A7	117	DQ52	261	VSS
17	VSS	161	DQ9	68	A8	212	VDD	118	VSS	262	DQ53
18	DQS10_t, DM1_n, DBI1_n, TDQS10_t	162	VSS	69	A6	213	A5	119	DQ48	263	VSS
19	DQS10_c, TDQS10_c	163	DQS1_c	70	VDD	214	A4	120	VSS	264	DQ49
20	VSS	164	DQS1_t	71	A3	215	VDD	121	DQS15_t, DM6_n, DBI6_n, TDQS15_t	265	VSS
21	DQ14	165	VSS	72	A1	216	A2	122	DQS15_c, TDQS15_c	266	DQS6_c
22	VSS	166	DQ15	73	VDD	217	VDD	123	VSS	267	DQS6_t
23	DQ10	167	VSS	74	CK0_t	218	CK1_t	124	DQ54	268	VSS
24	VSS	168	DQ11	75	CK0_c	219	CK1_c	125	VSS	269	DQ55
25	DQ20	169	VSS	76	VDD	220	VDD	126	DQ50	270	VSS
26	VSS	170	DQ21	77	VTT	221	VTT	127	VSS	271	DQ51
27	DQ16	171	VSS	78	EVENT_n	222	PARITY	128	DQ60	272	VSS
28	VSS	172	DQ17	79	A0	223	VDD	129	VSS	273	DQ61
29	DQS11_t, DM2_n, DBI2_n, TDQS11_t	173	VSS	80	VDD	224	BA1	130	DQ56	274	VSS
30	DQS11_c, TDQS11_c	174	DQS2_c	81	BA0	225	A10_AP	131	VSS	275	DQ57

Datasheet	11/28/2017
PS9MUxx64x8xxx	Viking Technology
Revision C	Page 7 of 41

Pin#	Description	Pin#	Description	Pin#	Description	Pin#	Description	Pin#	Description	Pin#	Description
31	VSS	175	DQS2_t	82	RAS_n/A16	226	VDD	132	DQS16_t, DM7_n, DBI7_n, TDQS16_t	276	VSS
32	DQ22	176	VSS	83	VDD	227	RFU	133	DQS16_c, TDQS16_c	277	DQS7_c
33	VSS	177	DQ23	84	S0_n	228	WE_n/A14	134	VSS	278	DQS7_t
34	DQ18	178	VSS	85	VDD	229	VDD	135	DQ62	279	VSS
35	VSS	179	DQ19	86	CAS_n/A15	230	SAVE_n, NC <sup>2</sup>	136	VSS	280	DQ63
36	DQ28	180	VSS	87	ODT0	231	VDD	137	DQ58	281	VSS
37	VSS	181	DQ29	88	VDD	232	A13	138	VSS	282	DQ59
38	DQ24	182	VSS	89	S1_n	233	VDD	139	SA0	283	VSS
39	VSS	183	DQ25	90	VDD	234	A17, NC	140	SA1	284	VDDSPD
40	DQS12_t, DM3_n, DBI3_n, TDQS12_t	184	VSS	91	ODT1	235	C[2], NC	141	SCL	285	SDA
41	DQS12_c, TDQS12_c	185	DQS3_c	92	VDD	236	VDD	142	VPP	286	VPP
42	VSS	186	DQS3_t	93	S2_n, C[0]	237	S3_n, C[1]	143	VPP	287	VPP
43	DQ30	187	VSS	94	VSS	238	SA2, RFU	144	RFU	288	VPP
44	VSS	188	DQ31	95	DQ36	239	VSS				
45	DQ26	189	VSS	96	VSS	240	DQ37				
46	VSS	190	DQ27	97	DQ32	241	VSS				
47	CB4, NC	191	VSS	98	VSS	242	DQ33				
48	VSS	192	CB5, NC	99	DQS13_t, DM4_n, DBI4_n, TDQS13_t	243	VSS				
49	CB0, NC	193	VSS	100	DQS13_c, TDQS13_c	244	DQS4_c				
50	VSS	194	CB1, NC	101	VSS	245	DQS4_t				
51	DQS17_t, DM8_n, DBI8_n, TDQS17_t	195	VSS								

**Notes:**

- VPP is 2.5V DC
- A15 needed for 4GBit DRAM, A16 needed for 8GBit DRAM, A17 needed for 16GBit DRAM
- Only x8 and x16 DRAM support Data Mask (DM) and Data Bus Inversion (DBI). Only x8 DRAM support TDQS
- DM & DBI functions are supported with dedicated one pin labeled as DM\_n/DBI\_n
- The pin is bi-directional pin for DRAM. The DM\_n/DBI\_n pin is Active Low as DDR4 supports VDDQ reference termination.
- DM & DBI functions are programmable through DRAM Mode Register (MR). The MR bit location is bit A11 in MR1 and bit A12:A10 in MR5 . Write operation: Either DM or DBI function can be enabled but both functions cannot be enabled simultaneously. When both DM and DBI functions are disabled, DRAM turns off its input receiver and does not expect any valid logic level. Read operation: Only DBI function applies. When DBI function is disabled, DRAM turns off its output driver and does not drive any valid logic level. DM & DBI functions are described in more detail on x8 based datasheets

Datasheet	11/28/2017
PS9MUxx64x8xxx	Viking Technology
Revision C	Page 8 of 41



## PIN FUNCTION DESCRIPTION

Pin Name	Description	Pin Name	Description
A0-A17 <sup>1</sup>	Register address input	SCL	I2C serial bus clock for SPD/TS and register
BA0, BA1	Register bank select input	SDA	I2C serial bus data line for SPD/TS and register
BG0, BG1	Register bank group select input	SA0-SA2	I2C slave address select for SPD/TS and register
RAS <sub>n</sub> <sup>2</sup>	Register row address strobe input	PAR	Register parity input
CAS <sub>n</sub> <sup>3</sup>	Register column address strobe input	VDD	SDRAM core power supply
WE <sub>n</sub> <sup>4</sup>	Register write enable input		
CS0 <sub>n</sub> , CS1 <sub>n</sub> , CS2 <sub>n</sub> , CS3 <sub>n</sub>	DIMM Rank Select Lines input		
CKE0, CKE1	Register clock enable lines input	VREFCA	SDRAM command/address reference supply
ODT0, ODT1	Register on-die termination control lines input	VSS	Power supply return (ground)
ACT <sub>n</sub>	Register input for activate input	VDDSPD	Serial SPD/TS positive power supply
DQ0-DQ63	DIMM memory data bus	ALERT <sub>n</sub>	Register ALERT <sub>n</sub> output
CB0-CB7	DIMM ECC check bits	Vpp	DRAM Activation Power Supply
TDQS9 <sub>t</sub> -TDQS17 <sub>t</sub>	Data Buffer data strobes (positive line of differential pair)		
TDQS9 <sub>c</sub> -TDQS17 <sub>c</sub>	Data Buffer data strobes (negative line of differential pair)	RESET <sub>n</sub>	Set Register and SDRAMs to a Known state
		EVENT <sub>n</sub>	SPD signals a thermal event has occurred.
CK0 <sub>t</sub> , CK1 <sub>t</sub>	Register clock input (positive line of differential pair)	Vtt	SDRAM I/O termination supply
CK0 <sub>c</sub> , CK1 <sub>c</sub>	Register clocks input (negative line of differential pair)	RFU	Reserved for future use

### Notes:

1. Address A17 is only valid for 16GBit DRAM
2. RAS<sub>n</sub> is a multiplexed function with A16. (A16 needed for 8GBit DRAM)
3. CAS<sub>n</sub> is a multiplexed function with A15. (A15 needed for 4GBit DRAM)
4. WE<sub>n</sub> is a multiplexed function with A14

Datasheet	11/28/2017
PS9MUxx64x8xxx	Viking Technology
Revision C	Page 9 of 41

## Input/Output Functional Descriptions

Symbol	Type	Function
CK_t, CK_c	Input	Clock: CK_t and CK_c are differential clock inputs. All address and control input signals are sampled on the crossing of the positive edge of CK_t and negative edge of CK_c.
CKE0, (CKE1)	Input	Clock Enable: CKE HIGH activates, and CKE Low deactivates, internal clock signals and device input buffers and output drivers. Taking CKE Low provides Precharge Power-Down and Self-Refresh operation (all banks idle), or Active Power-Down (row Active in any bank). CKE is asynchronous for Self-Refresh exit. After VREFCA and VREFDQ have become stable during the power on and initialization sequence, they must be maintained during all operations (including Self-Refresh). CKE must be maintained high throughout read and write accesses. Input buffers, excluding CK, CK_c, ODT and CKE, are disabled during power-down. Input buffers, excluding CKE, are disabled during Self-Refresh.
CS0_n, (CS1_n)	Input	Chip Select: All commands are masked when CS_n is registered HIGH. CS_n provides for external Rank selection on systems with multiple Ranks. CS_n is considered part of the command code.
C0,C1,C2	Input	Chip ID: Chip ID is only used for 3DS for 2,4,8high stack via TSV to select each slice of stacked component. Chip ID is considered part of the command code.
ODT0, (ODT1)	Input	On Die Termination: ODT (registered HIGH) enables termination resistance internal to the DDR4 SDRAM. When enabled, ODT is only applied to each DQ, DQS_t, DQS_c and DM_n/DBI_n/TDQS_t,NU/TDQS_c (When TDQS is enabled via Mode Register A11=1 in MR1) signal for x8 configurations. For x16 configuration ODT is applied to each DQ, DQSU_c, DQSU_t, DQSL_t, DQSL_c, DMU_n, and DML_n signal. The ODT pin will be ignored if MR1 is programmed to disable RTT_NOM.
ACT_n	Input	Activation Command Input: ACT_n defines the Activation command being entered along with CS_n. The input into RAS_n/A16, CAS_n/A15 and WE_n/A14 will be considered as Row Address A16, A15 and A14.
RAS_n/A16, CAS_n/A15, WE_n/A14	Input	Command Inputs RAS_n/A16, CAS_n/A15 and WE_n/A14 (along with CS_n) define the command being entered. Those pins have multi function. For example, for activation with ACT_n Low, those are Addressing like A16,A15 and A14 but for non-activation command with ACT_n High, those are Command pins for Read, Write and other command defined in command truth table.
DM_n/DBI_n/ TDQS_t, (DMU_n/DBIU_n), (DML_n/DBIL_n)	Input/ Output	Input Data Mask and Data Bus Inversion: DM_n is an input mask signal for write data. Input data is masked when DM_n is sampled LOW coincident with that input data during a Write access. DM_n is sampled on both edges of DQS. DM is muxed with DBI function by Mode Register A10,A11,A12 setting in MR5. For x8 device, the function of DM or TDQS is enabled by Mode Register A11 setting in MR1. DBI_n is an input/output identifying whether to store/output the true or inverted data. If DBI_n is LOW, the data will be stored/output after inversion inside the DDR4 SDRAM and not inverted if DBI_n is HIGH. TDQS is only supported in x8.
BG0 - BG1	Input	Bank Group Inputs: BG0 - BG1 define to which bank group an Active, Read, Write or Precharge command is being applied. BG0 also determines which mode register is to be accessed during a MRS cycle. x4/8 have BG0 and BG1 but x16 has only BG0.

### Input/Output Functional Descriptions (cont.)

Symbol	Type	Function
BA0 - BA1	Input	Bank Address Inputs: BA0 - BA1 define to which bank an Active, Read, Write or Precharge command is being applied. Bank address also determines if the mode register or extended mode register is to be accessed during a MRS cycle.
A0 - A17	Input	Address Inputs: Provided the row address for ACTIVATE Commands and the column address for Read/Write commands to select one location out of the memory array in the respective bank. (A10/AP, A12/BC_n, RAS_n/A16, CAS_n/A15 and WE_n/A14 have additional functions, see other rows. The address inputs also provide the op-code during Mode Register Set commands. A17 is only defined for the x4 configuration.
A10 / AP	Input	Auto-precharge: A10 is sampled during Read/Write commands to determine whether Autoprecharge should be performed to the accessed bank after the Read/Write operation. (HIGH: Autoprecharge; LOW: no Autoprecharge). A10 is sampled during a Precharge command to determine whether the Precharge applies to one bank (A10 LOW) or all banks (A10 HIGH). If only one bank is to be precharged, the bank is selected by bank addresses.
A12 / BC_n	Input	Burst Chop: A12 / BC_n is sampled during Read and Write commands to determine if burst chop (on-the-fly) will be performed. (HIGH, no burst chop; LOW: burst chopped). See command truth table for details.
RESET_n	Input	Active Low Asynchronous Reset: Reset is active when RESET_n is LOW, and inactive when RESET_n is HIGH. RESET_n must be HIGH during normal operation. RESET_n is a CMOS rail to rail signal with DC high and low at 80% and 20% of VDD.
DQ	Input / Output	Data Input/ Output: Bi-directional data bus. If CRC is enabled via Mode register then CRC code is added at the end of Data Burst. Any DQ from DQ0~DQ3 may indicate the internal Vref level during test via Mode Register Setting MR4 A4=High. Refer to vendor specific datasheets to determine which DQ is used.
DQS_t, DQS_c, DQSU_t, DQSU_c, DQSL_t, DQSL_c	Input / Output	Data Strobe: output with read data, input with write data. Edge-aligned with read data, centered in write data. For x16, DQSL corresponds to the data on DQL0-DQL7; DQSU corresponds to the data on DQU0-DQU7. The data strobe DQS_t, DQSL_t, and DQSU_t are paired with differential signals DQS_c, DQSL_c, and DQSU_c, respectively, to provide differential pair signaling to the system during reads and writes. DDR4 SDRAM supports differential data strobe only and does not support single-ended.

Datasheet	11/28/2017
PS9MUxx64x8xxx	Viking Technology
Revision C	Page 11 of 41

### Input/Output Functional Descriptions (cont.)

Symbol	Type	Function
ALERT_n	Output	Alert: It has multi functions such as CRC error flag, Command and Address Parity error flag. If there is error in CRC, then Alert_n goes LOW for the period time interval and goes back HIGH. IF there is error in Command Address Parity Check, then Alert_n goes LOW for relatively long period until on going DRAM internal recovery transaction to complete.
TEN	Input	Boundary Scan Mode Enable: Required on x16 devices and optional input on x4/x8 with densities equal to or greater than 8Gb. HIGH in this pin will enable boundary scan operation along with other pins. It is a CMOS rail to rail signal with DC high and low at 80% and 20% of VDD.
NC		No Connect: No internal electrical connection is present.
VDDQ	Supply	DQ Power Supply: 1.2 V +/- 0.06 V
VSSQ	Supply	DQ Ground
VDD	Supply	Power Supply: 1.2 V +/- 0.06 V
VSS	Supply	Ground
Vpp	Supply	DRAM Activation Power Supply: 2.5V (2.375V min , 2.75 max)
VREFCA	Supply	Reference voltage for CA
ZQ	Supply	Reference Pin for ZQ calibration

**Note:**

The input only pins (BG0-BG-1, BA0-BA1, A0-A17, ACT\_n, RAS\_n/A16, CAS\_n/A15, WE\_n/A14, CS\_n, CKE, ODT, and RESET\_n) do not supply termination.

## MECHANICAL OUTLINE

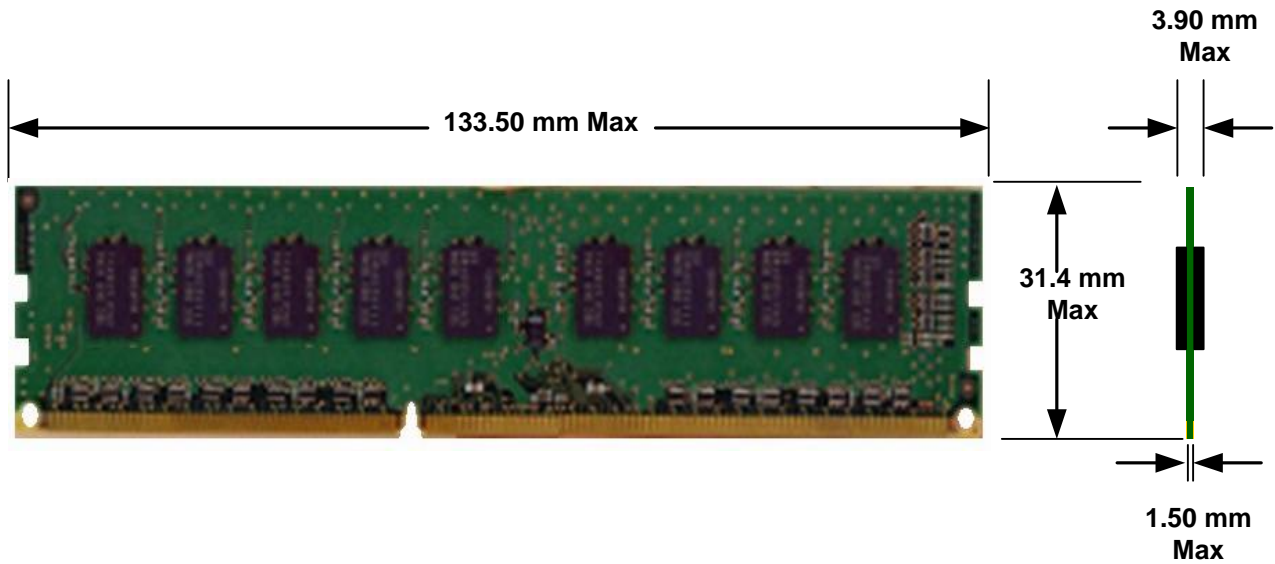

**Notes:**

- All dimensions in mm (inches)
- Tolerance is +/- 0.0127, unless otherwise stated
- Refer to JEDEC Standard Mechanical Outline MO-309 for other details

Datasheet	11/28/2017
PS9MUxx64x8xxx	Viking Technology
Revision C	Page 13 of 41

## FUNCTIONAL BLOCK DIAGRAM

Signal Groups:

1. Clock (CK)
2. Address, Bank Address, Bank Group and Command (ADD/CMD)
3. Control (CTRL)
4. Data Bus (including ECC byte) (DQ)

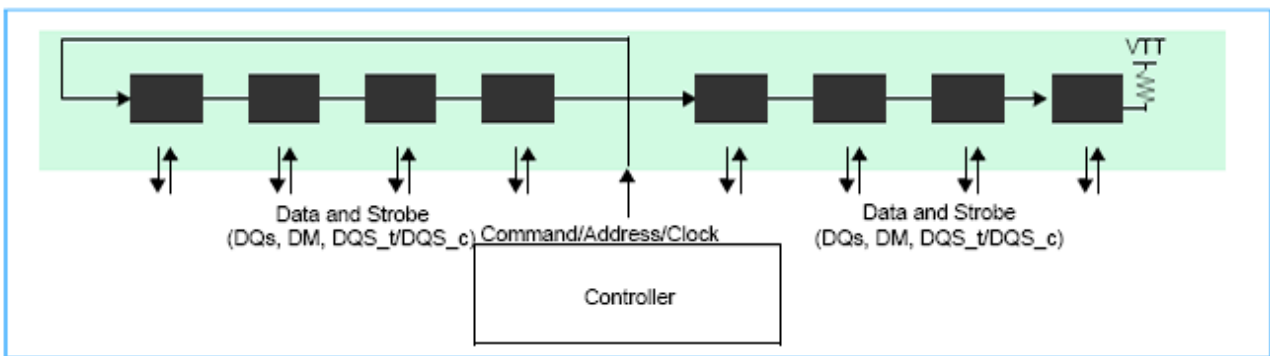

BA[1:0]	→	BA[1:0]: DDR4 SDRAM
BG[1:0]	→	BG[1:0]: DDR4 SDRAM
ACT <sub>n</sub>	→	ACT <sub>n</sub> : DDR4 SDRAM
A[13:0]	→	A[13:0]: DDR4 SDRAM
RAS <sub>n</sub> /A16	→	RAS <sub>n</sub> /A16: DDR4 SDRAM
CAS <sub>n</sub> /A15	→	CAS <sub>n</sub> /A15: DDR4 SDRAM
WE <sub>n</sub> /A14	→	WE <sub>n</sub> /A14: DDR4 SDRAM
CKE0	→	CKE0: Rank 0
CKE1	→	CKE1: Rank 1
ODT0	→	ODT0: Rank 0
ODT1	→	ODT1: Rank 1
RESET	→	RESET <sub>n</sub> : DDR4 SDRAM
PARITY	→	PARITY: DDR4 SDRAM
ALERT <sub>n</sub>	←	ALERT <sub>n</sub> : DDR4 SDRAM

$V_{DD}$   
 $\approx 50\Omega$

Datasheet	11/28/2017
PS9MUxx64x8xxx	Viking Technology
Revision C	Page 14 of 41

Rank 0: U1–U8  
Rank 1: U10–U17

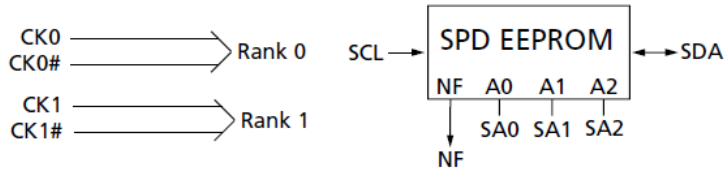

Clock, control, command, and address line terminations:

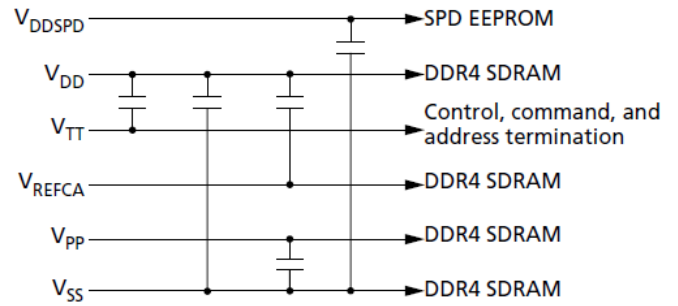
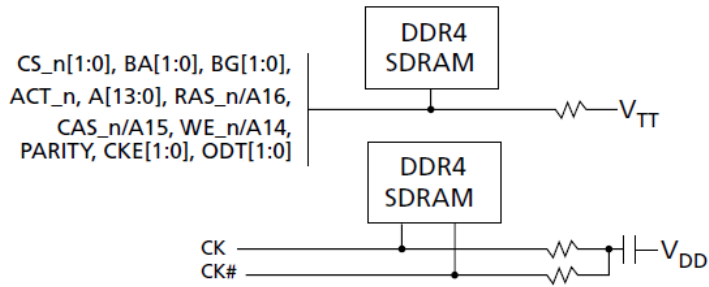

**Notes:**

- The ZQ ball on each DDR4 component is connected to an external 240Ω ±1% resistor that is tied to ground. It is used for the calibration of the component's ODT and output driver.

Datasheet	11/28/2017
PS9MUxx64x8xxx	Viking Technology
Revision C	Page 15 of 41

## DQ Internal Vref Specifications

Parameter	Symbol	Min	Typ	Max	Unit	NOTE
Vref Max operating point Range 1	Vref_max_R1	-	-	92%	VDDQ	1, 11
Vref Min operating point Range 1	Vref_min_R1	60%	-	-	VDDQ	1,11
Vref Max operating point Range 2	Vref_max_R2	-	-	77%	VDDQ	1, 11
Vref Min operating point Range 2	Vref_min_R2	45%	-	-	VDDQ	1,11
Vref Stepsize	Vref_step	0.50%	0.65%	0.80%	VDDQ	2
Vref Set Tolerance	Vref_set_tol	-1.625%	0.00%	1.63%	VDDQ	3,4,6
		-0.15%	0.00%	0.15%	VDDQ	3,5,7
Vref Step Time	Vref_time-long	-	-	150	ns	9
	Vref_time-Short	-	-	60	ns	8
Vref Valid tolerance	Vref_val_tol	-0.15%	0.00%	0.15%	VDDQ	10

### Notes:

- JESD8-24 specifies Vref to be 70% of VDDQ. Vref DC voltage referenced to VDDQ\_DC. VDDQ\_DC is 1.2V
- Vref stepsize increment/decrement range. Vref at DC level.
- $Vref\_new = Vref\_old + n * Vref\_step$ ; n=number of step; if increment use "+"; If decrement use "-"
- The minimum value of Vref setting tolerance= $Vref\_new - 1.625% * VDDQ$ .  
The maximum value of Vref setting tolerance= $Vref\_new + 1.625% * VDDQ$ . For n>4
- The maximum value of Vref setting tolerance= $Vref\_new - 0.15% * VDDQ$ .  
The maximum value of Vref setting tolerance= $Vref\_new + 0.15% * VDDQ$ . For n&4 tbd
- Measured by recording the min and max values of the Vref output over the range, drawing a straight line between those points and comparing all other Vref output settings to that line
- Measured by recording the min and max values of the Vref output across 4 consecutive steps(n=4), drawing a straight line between those points and comparing all other Vref output settings to that line
- Time from MRS command to increment of decrement one step size for Vref
- Time from MRS command to increment of decrement more than one step size up to full range of Vref
- Only applicable for DRAM component level test/characterization purpose.  
Not applicable for normal mode of operation. Vref valid is to qualify the step times which will be characterized at the component level.
- DRAM range1 or 2 set by MRS bit MR6,A6.

Datasheet	11/28/2017
PS9MUxx64x8xxx	Viking Technology
Revision C	Page 16 of 41



## OVERVIEW OF DDR4 UDIMM MODULE OPERATION

The DDR4 architecture is generally a point-to-point topology with a dedicated channel design. The highest system performance levels can be achieved with DDR4-2133 and beyond, when the system is configured as 1 UDIMM Per Channel (1DPC). DDR4 has more features than DDR3 with a pseudo-open drain (POD12) 1.2v I/O for the data channel, trained Vref, bank groups and write CRC. The POD12 interface only applies to the data channel. The address command channel behave like DDR3 using mid-point termination and mid-point Vref. The new bank group interleaving feature in DDR4 maximizes data transfer bandwidth.

DDR4 DRAM use pseudo-open drain (POD12) 1.2v drivers with Vdd terminations on DQ lines to increase data rates; unlike DDR3 DRAM that uses stub-series terminated logic drivers, The DRAM addressing scheme in DDR4 is organized into bank groups, Side A and Side B. The host DDR4 memory controller interleaves (multiplexes) among the bank groups to achieve high data rates. DDR4 architecture is a 8n prefetch with bank groups, including the use of two or four selectable bank groups. This will permit the DDR4 memory devices to have separate activation, read, write or refresh operations simultaneously underway in each of the unique bank groups to improve overall memory efficiency and bandwidth, especially when small memory granularities are used.

The data written to the UDIMM is read back the same way. However when writing to the internal registers with a "load mode" operation, a specific address is required. This requires the controller to know if the rank is mirrored or not. There is a bit assignment in the SPD that indicates whether the module has been designed with a mirrored feature or not.

DDR4 offers CRC parity as an optional feature on address command and data; (Error command blocking when parity enabled and post CA parity. If the UDIMM does not support CRC, the values of 0x00 will fill the CRC table. The new CA parity feature on the command/address bus provides a low-cost method of verifying the integrity of command and address transfers over a link, for all operations.

Some of the main attributes of DDR4 memory are:

- 1) Internally generated VrefDQ and Calibration.  
VrefDQ is supplied by the DRAM internally.  
VrefCA is supplied by the board.
- 2) The ACT\_n activate pin replaces RAS#, CAS#, and WE# commands,
- 3) Alert\_n for error checking
- 4) Bank group Interleaving
- 5) Improved training modes upon power-up
- 5) Nominal and dynamic ODT: Improvements to the ODT protocol and a new Park Mode allow for a nominal termination and dynamic write termination without having to drive the ODT pin
- 6) DQ bus gear-down mode for 2667 Mhz data rates and beyond
- 7) External VPP at 2.5V (for wordline boost)
- 8) 1.2V VDD power with power-saving features that include MPSM Maximum Power Savings Mode, Low Power Auto Self Refresh, Temperature Controlled Refresh, Fine Granularity Refresh, and CMD/ADDT latency. DLL off mode.

### Important Note:

Longer boot-up times may be experienced in certain situations due to controller initiated functions such as VrefDQ calibration, write leveling and other trainings for the UDIMM.

Datasheet	11/28/2017
PS9MUxx64x8xxx	Viking Technology
Revision C	Page 17 of 41

## DDR4 MODE REGISTERS

	A12	A11	A10	A9	A8	A7	A6	A5	A4	A3	A2	A1	A0
<b>MR0</b>	RFU	Write Recovery and RTP			DLL Reset	Test Mode	CAS Latency CL			Burst Type	CL	Burst Length BL	
<b>MR1</b>	Qoff	TDQS	Rtt_NOM			Write Leveling	RFU	RFU	Additive Latency		Ron		DLL Enable
<b>MR2</b>	Write CRC	RFU	Rtt_WR		RFU	Auto Self Refresh		CWL			RFU	RFU	RFU
<b>MR3</b>	MPR Read Format		Write CMD Latency with CRC and DM		Fine Granularity Refresh			Temp Sensor	Per-DRAM Addr Mode	Gear down	MPR Enable	MPR Page	
<b>MR4</b>	Write Preamble	Read Preamble	Read Preamble Training Enable	Self Refresh Abort Enable	CS-to-Address Latency CAL			RFU	VrefDQ Monitor Enable	Temp Refresh Mode	Temp. Refresh Range	Max Power Down Enable	RFU
<b>MR5</b>	Read DBI Enable	Write DBI Enable	Data Mask Enable	Parity Persistent Error	Rtt_PARK			ODT input in Power Down	Panty Error Status	CRC Error Clear	CMD Address Parity Latency		
<b>MR6</b>	tCCD_L and tDLLK Timing			RFU	RFU	VrefDQ Training enable	VrefDQ Training Range	VretDQ Training Value					
<b>MR7</b>	Manufacturing use only to program the RCD												

### Notes:

- Refer to JEDEC documentation for detail of the control/status bits

Datasheet	11/28/2017
PS9MUxx64x8xxx	Viking Technology
Revision C	Page 18 of 41

## DC OPERATING CONDITIONS AND CHARACTERISTICS

### ABSOLUTE MAXIMUM RATINGS

Parameter	Symbol	Value	Unit	Notes
Voltage on any pin relative to GND	Vin, Vout	-0.3 ~ 1.5	V	1,
Voltage on VDD supply relative to GND	VDD	-0.3 ~ 1.5	V	1,3
Voltage on VDDQ supply relative to GND	VDDQ	-0.3 ~ 1.5	V	1,3
Voltage on VPP supply relative to GND	VPP	-0.3 ~ 3.0	V	4
Module operating temperature (ambient)	T <sub>opr</sub>	0 ~ 55	°C	1,5
Storage temperature	T <sub>stg</sub>	-55 ~ +100	°C	1,2

#### Notes:

- Permanent device damage may occur if 'ABSOLUTE MAXIMUM RATINGS' are exceeded. Functional operation should be restricted to recommended operating condition.  
Exposure to higher than recommended voltage for extended periods of time could affect device reliability. Stresses greater than those listed under "Absolute Maximum Ratings" may cause permanent damage to the device. This is a stress rating only and functional operation of the device at these or any other conditions above those indicated in the operational sections of this specification is not implied. Exposure to absolute maximum rating conditions for extended periods may affect reliability
- Storage Temperature is the case surface temperature on the center/top side of the DRAM. For the measurement conditions, please refer to JESD51- 2 standard.
- VDD and VDDQ must be within 300 mV of each other at all times and VREFCA must be not greater than 0.6 x VDDQ, When VDD and VDDQ are less than 500 mV; VREF may be equal to or less than 300 mV
- VPP must be equal or greater than VDD/VDDQ at all times
- Refer to JEDEC JC451 specification

### DRAM Component Operating Temperature Range

Symbol	Parameter	Rating	Units	Note
T <sub>oper</sub>	Normal Operating Temperature Range	0 to 85	°C	1,2
	Extended Temperature Range	85 to 95	°C	1,3

#### Notes:

- Operating Temperature TOPER is the case surface temperature on the center / top side of the DRAM. For measurement conditions, please refer to the JEDEC document JE51-2.
- The Normal Temperature Range specifies the temperatures where all DRAM specifications will be supported. During operation, the DRAM case temperature must be maintained between 0 - 85°C under all operating conditions.
- Some applications require operation of the DRAM in the Extended Temperature Range between 85°C and 95°C case temperature. Full specifications are guaranteed in this range, but the following additional conditions apply:
  - Refresh commands must be doubled in frequency, therefore reducing the Refresh interval tREFI to 3.9 μs. It is also possible to specify a component with 1X refresh (tREFI to 7.8μs) in the Extended Temperature Range. Please refer to the DIMM SPD for option availability.
  - If Self-Refresh operation is required in the Extended Temperature Range, then it is mandatory to either use the Manual Self-Refresh mode with Extended Temperature Range capability (MR2 A6 = 0b and MR2 A7 = 1b) or enable the optional Auto Self-Refresh mode (MR2 A6 = 1b and MR2 A7 = 0b). DDR4 SDRAMs support Auto Self-Refresh and in Extended Temperature Range and please refer to component datasheet and/or the DIMM SPD for tREFI requirements in the Extended Temperature Range

### tREFI by Device Density

Parameter	Symbol	2Gb	4Gb	8Gb	16Gb	Units	
Average periodic refresh interval	tREFI	0°C ≤ T <sub>case</sub> ≤ 85°C	7.8	7.8	7.8	7.8	μs
		85°C ≤ T <sub>case</sub> ≤ 95°C	3.9	3.9	3.9	3.9	μs

Datasheet	11/28/2017
PS9MUxx64x8xxx	Viking Technology
Revision C	Page 19 of 41

## AC & DC Operating Conditions

### DC OPERATING CONDITIONS AND CHARACTERISTICS (POD12)

Symbol	Parameter	Rating			Units	Notes
		Min	Typ	Max		
VDD	Supply Voltage VDD: PC4:1.2V±5%,	1.14	<b>1.2</b>	1.26	v	1,2,3
VDDQ	Supply Voltage for Output. Values in () are at 70% of VDD	1.14 (0.798)	1.2 (0.84)	1.26 (0.882)	v	1
VPP	2.5V +10%, -5%	2.375	2.5	2.75	v	3
VDDSPD	@2.5V	2.2	2.5	2.8	v	

**Notes:**

1. JESD8-24 specifies Vref to be 70% of VDDQ. Under all conditions VDDQ must be less than or equal to VDD.
2. VDDQ tracks with VDD. AC parameters are measured with VDD and VDDQ tied together.
3. DC bandwidth is limited to 20MHz.,
4. POD12 1.2 V Pseudo Open Drain Interface has a VDDQ value of 1.2V but the reference voltage allows POD12 to be used with other VDDQ values. POD12 signals have pull-up-only parallel input termination and have an asymmetric output drive impedance. For example, if the output drivers were using a 60 ohm pull-up drive impedance then the pull-down drivers would be expected to produce a 40 ohm pull-down drive impedance. POD12 does not explicitly call for series termination resistors, so it is suitable for point-to-point as well as multi-drop stub environments which may require some additional termination.

Datasheet	11/28/2017
PS9MUxx64x8xxx	Viking Technology
Revision C	Page 20 of 41

## DC CHARACTERISTICS, IDD CURRENTS

### IDD DEFINITIONS

Symbol	Parameter
IDD0	One bank ACTIVATE-PRECHARGE current
IPP0	One bank ACTIVATE-PRECHARGE, Word Line Boost, IPP current
IDD1	One bank ACTIVATE-READ-PRECHARGE current
IDD2N	Precharge standby current
IDD2NT	Precharge standby ODT current
IDD2P	Precharge power-down current
IDD2Q	Precharge quiet standby current
IDD3N	Active standby current
IPP3N	Active standby IPP current
IDD3P	Active power-down current
IDD4R	Burst read current
IDDQ4R	Burst read IDDQ current
IDD4W	Burst write current
IDD5B	Burst refresh current (1x REF)
IPP5B	Burst refresh IPP current (1 x REF)
IDD6N	Self refresh current: Normal temperature range (0°C to +85°C)
IDD6E	Self refresh current: Extended temperature range (0°C to +95°C)
IDD6R	Self refresh current: Reduced temperature range (0°C to +45°C)
IDD6A	Auto self refresh current (25°C)
IDD6A	Auto self refresh current (45°C)
IDD6A	Auto self refresh current (75°C)
IDD7	Bank interleave read current
IPP7	Bank interleave read IPP current
IDD8	Maximum power-down current

#### Notes:

- 1) DDR4 IDD and IDDQ specs include the same DDR3 IDD and IDDQ specs with these exceptions:
  - a. IDD2P0 and IDD2P1 are replaced with a single IDD2P. There's no longer any difference in power for the DLL because of better DLL power management inside the DRAM device without any benefit for using slow exit.
  - b. IDD6 is renamed IDD6N Self Refresh Current: Normal Temperature Range
  - c. IDD6ET is renamed IDD6E Self-Refresh Current: Extended Temperature Range
  - d. IDD6TC is renamed IDD6AAut0 Self-Refresh Current
  - e. IDD8 is redefined from (optional) RESET Low Current to IDD8 Maximum Power Down Current, TBD
- 2) IDD values are an average (not peak) current drawn throughout the entire time that it takes to execute the set of conditions specified by JEDEC standards.
- 3) Consult with Viking for tools to help specify the Total Design Power (TDP)

Datasheet	11/28/2017
PS9MUxx64x8xxx	Viking Technology
Revision C	Page 21 of 41

### ***I<sub>DD6</sub>* Specification**

<b>Symbol</b>	<b>Temperature Range</b>	<b>Value</b>	<b>Unit</b>	<b>Notes</b>
IDD6N	0 - 85 °C	22	mA	3,4
IDD6E	0 - 95 °C	33	mA	4,5,6
IDD6R	0 - 45°C	10	mA	4,6,9
IDD6A	0 °C ~ Ta	9	mA	4,6,7,8
	Tb ~ Ty	10	mA	4,6,7,8
	Tz ~ TOPERmax	16	mA	4,6,7,8

**Notes:**

1. Some IDD currents are higher for x16 organization due to larger page-size architecture.
2. Max. values for IDD currents considering worst case conditions of process, temperature and voltage.
3. Applicable for MR2 settings A6=0 and A7=0.
4. Supplier data sheets include a max value for IDD6.
5. Applicable for MR2 settings A6=0 and A7=1. IDD6ET is only specified for devices which support the Extended Temperature Range feature.
6. Refer to the supplier data sheet for the value specification method (e.g. max, typical) for IDD6ET and IDD6TC
7. Applicable for MR2 settings A6=1 and A7=0. IDD6TC is only specified for devices which support the Auto Self Refresh feature.
8. The number of discrete temperature ranges supported and the associated Ta - Tz values are supplier/design specific. Temperature ranges are specified for all supported values of TOPER. Refer to supplier data sheet for more information.
9. Applicable for MR2 settings TBD. IDD6R is verified by design and characterization, and may not be subject to production test.

Datasheet	11/28/2017
PS9MUxx64x8xxx	Viking Technology
Revision C	Page 22 of 41

**IDD CURRENTS, SINGLE RANK, 4Gbit**

Symbol	DDR4-1866	DDR4-2133	DDR4-2400	Units
IDD0	464	480	512	mA
IPP0	32	32	32	mA
IDD1	504	520	544	mA
IDD2N	352	368	400	mA
IDD2NT	400	432	464	mA
IDD2P	240	240	256	mA
IDD2Q	312	312	328	mA
IDD3N	488	504	536	mA
IPP3N	24	24	24	mA
IDD3P	352	352	352	mA
IDD4R	1120	1200	1280	mA
IDDQ4R	256	288	320	mA
IDD4W	1248	1408	1568	mA
IDD5B	1520	1520	1536	mA
IPP5B	176	176	176	mA
IDD6N	160	160	160	mA
IDD6E	216	216	216	mA
IDD6R	80	80	80	mA
IDD6A (25°C)	72	72	72	mA
IDD6A (45°C)	80	80	80	mA
IDD6A (75°C)	128	128	128	mA
IDD7	1280	1480	1680	mA
IPP7	80	96	112	mA
IDD8	144	144	144	mA

**Notes:**

1. Users should refer to the DRAM supplier data sheet and/or the DIMM SPD to determine if DDR4 SDRAM devices support the following options or requirements referred to in this material.
2. Values as per Micron Datasheet Revision "A".

Datasheet	11/28/2017
PS9MUxx64x8xxx	Viking Technology
Revision C	Page 23 of 41

### IDD CURRENTS, 2 RANK, 4Gbit

Symbol	DDR4-1866	DDR4-2133	DDR4-2400	Units
IDD0 <sup>1</sup>	928			mA
IPP0 <sup>1</sup>	64	64		mA
IDD1 <sup>1</sup>	1008	1040	1088	mA
IDD2N <sup>2</sup>	592	608	640	mA
IDD2NT <sup>1</sup>	800	864	928	mA
IDD2P <sup>2</sup>	480	480	496	mA
IDD2Q <sup>2</sup>	552	552	568	mA
IDD3N <sup>2</sup>	728	744	776	mA
IPP3N <sup>2</sup>	264	264	264	mA
IDD3P <sup>2</sup>	592	592	592	mA
IDD4R <sup>1</sup>	2240	2400	2560	mA
IDDQ4R <sup>1</sup>	512	576	640	mA
IDD4W <sup>1</sup>	2496	2816	3136	mA
IDD5B <sup>1</sup>	3040	3040	3072	mA
IPP5B <sup>1</sup>	352	352	352	mA
IDD6N <sup>2</sup>	400	400	400	mA
IDD6E <sup>2</sup>	456	456	456	mA
IDD6R <sup>2</sup>	320	320	320	mA
IDD6A <sup>2</sup> (25°C)	312	312	312	mA
IDD6A <sup>2</sup> (45°C)	320	320	320	mA
IDD6A <sup>2</sup> (75°C)	368	368	368	mA
IDD7 <sup>1</sup>	2560	2960	3360	mA
IPP7 <sup>1</sup>	160	192	224	mA
IDD8 <sup>2</sup>	384	384	384	mA

**Notes:**

1. One module rank in the active IDD/PP, the other rank in IDD2P/PP3N.
2. All ranks in this IDD/PP condition.
3. Values as per Micron Datasheet Revision "A".



### IDD CURRENTS, SINGLE RANK, 8Gbit

Symbol	DDR4-2133	DDR4-2400	Units
	15-15-15	17-17-17	
	1.2V	1.2V	
IDD0	280	296	mA
IDD0A	296	312	mA
IDD1	400	424	mA
IDD1A	416	448	mA
IDD2N	176	184	mA
IDD2NA	200	208	mA
IDD2NT	200	208	mA
IDD2NL	120	136	mA
IDD2NG	176	184	mA
IDD2ND	160	168	mA
IDD2N_par	184	192	mA
IDD2P	128	128	mA
IDD2Q	160	168	mA
IDD3N	288	288	mA
IDD3NA	304	304	mA
IDD3P	168	176	mA
IDD4R	824	904	mA
IDD4RA	856	944	mA
IDD4RB	840	928	mA
IDD4W	672	720	mA
IDD4WA	704	760	mA
IDD4WB	752	720	mA
IDD4WC	592	640	mA
IDD4W_par	736	792	mA
IDD5B	1752	1776	mA
IDD5F2	1232	1240	mA
IDD5F4	1024	1040	mA
IDD6N	184	184	mA
IDD6E	272	272	mA
IDD7	1360	1384	mA
IDD8	88	88	mA

**Notes:**

1. Users should refer to the DRAM supplier data sheet and/or the DIMM SPD to determine if DDR4 SDRAM devices support the following options or requirements referred to in this material.
2. Values as per Samsung Datasheet Revision "D".

Datasheet	11/28/2017
PS9MUxx64x8xxx	Viking Technology
Revision C	Page 25 of 41

## IDD CURRENTS, DUAL RANK, 8Gbit

Symbol	DDR4-2133		Units
	15-15-15		
	1.2V		
	DDR4-2400		
	17-17-17		
	1.2V		
IDD0 <sup>1</sup>	560	592	mA
IDD0A <sup>1</sup>	592	624	mA
IDD1 <sup>1</sup>	800	848	mA
IDD1A <sup>1</sup>	832	896	mA
IDD2N <sup>2</sup>	416	424	mA
IDD2NA <sup>1</sup>	400	416	mA
IDD2NT <sup>1</sup>	400	416	mA
IDD2NL <sup>1</sup>	240	272	mA
IDD2NG <sup>1</sup>	352	368	mA
IDD2ND <sup>1</sup>	320	336	mA
IDD2N_par <sup>1</sup>	368	384	mA
IDD2P <sup>2</sup>	368	368	mA
IDD2Q <sup>2</sup>	400	408	mA
IDD3N <sup>2</sup>	528	528	mA
IDD3NA <sup>2</sup>	544	544	mA
IDD3P <sup>2</sup>	408	416	mA
IDD4R <sup>1</sup>	1648	1808	mA
IDD4RA <sup>1</sup>	1712	1888	mA
IDD4RB <sup>1</sup>	1680	1856	mA
IDD4W <sup>1</sup>	1344	1440	mA
IDD4WA <sup>1</sup>	1408	1520	mA
IDD4WB <sup>1</sup>	1504	1440	mA
IDD4WC <sup>1</sup>	1184	1280	mA
IDD4W_par <sup>1</sup>	1472	1584	mA
IDD5B <sup>1</sup>	3504	3552	mA
IDD5F2 <sup>1</sup>	2464	2480	mA
IDD5F4 <sup>1</sup>	2048	2080	mA
IDD6N <sup>2</sup>	424	424	mA
IDD6E <sup>2</sup>	512	512	mA
IDD7 <sup>1</sup>	2720	2768	mA
IDD8 <sup>2</sup>	328	328	mA

**Notes:**

1. One module rank in the active IDD/PP, the other rank in IDD2P/PP3N.
2. All ranks in this IDD/PP condition.
3. Users should refer to the DRAM supplier data sheet and/or the DIMM SPD to determine if DDR4 SDRAM devices support the following options or requirements referred to in this material.
4. Values as per Samsung Datasheet Revision "D"
5. IDD6 Specification per Samsung K4A8G085WB, the values mentioned are: IDD6N - 23 mA IDD6E - 34 mA  
But in Micron datasheets, IDD6N - 20 Ma IDD6E - 27 mA

Datasheet	11/28/2017
PS9MUxx64x8xxx	Viking Technology
Revision C	Page 26 of 41

## Input/Output Capacitance

Symbol	Parameter	DDR4-1600, 1867, 2133		DDR4-2400,2667		DDR4-3200		Units	Note
		Min	Max	Min	Max	Min	Max		
C <sub>IO</sub>	Input/output capacitance	0.7	1.4	0.7	1.3	TBD	TBD	pF	1,2,3
C <sub>DIO</sub>	Input/output capacitance delta	-0.1	0.1	-0.1	0.1	TBD	TBD	pF	1,2,3,1 1
C <sub>DDQS</sub>	Input/output capacitance delta DQS and DQS#		0.05		0.05	TBD	TBD	pF	1,2,3,5
C <sub>CK</sub>	Input capacitance, CK and CK#	0.2	0.8	0.2	0.8	TBD	TBD	pF	1,3
C <sub>DCK</sub>	Input capacitance delta CK and CK#		0.05		0.05	TBD	TBD	pF	1,3,4
C <sub>I</sub>	Input capacitance(CTRL, ADD, CMD pins only)	0.2	0.8	0.2	0.7	TBD	TBD	pF	1,3,6
C <sub>DI_CTRL</sub>	Input capacitance delta(All CTRL pins only)	-0.1	0.1	-0.1	0.1	TBD	TBD	pF	1,3,7,8
C <sub>DI_ADD_CMD</sub>	Input capacitance delta(All ADD/CMD pins only)	-0.1	0.1	-0.1	0.1	TBD	TBD	pF	1,2,9, 10
C <sub>ALERT</sub>	Input/output capacitance of ALERT	0.5	1.5	0.5	1.5	TBD	TBD	pF	1,3
C <sub>ZQ</sub>	Input/output capacitance of ZQ	0.5	1.5	0.5	1.5	TBD	TBD	pF	1,3,12

### Notes:

1. This parameter is not subject to production test. It is verified by design and characterization. The silicon only capacitance is validated by de-embedding the package L & C parasitic. The capacitance is measured with VDD, VDDQ, VSS, VSSQ applied with all other signal pins floating. Measurement procedure tbd.
2. DQ, DM, DQS\_T, DQS\_C, TDQS\_T, TDQS\_C. Although the DM, TDQS\_T and TDQS\_C pins have different functions, the loading matches DQ and DQS
3. This parameter applies to monolithic devices only; stacked/dual-die devices are not covered here.
4. Absolute value C<sub>K\_T-CK\_C</sub>
5. Absolute value of C<sub>IO(DQS\_T)</sub>-C<sub>IO(DQS\_C)</sub>
6. C<sub>I</sub> applies to ODT, CS\_n, CKE, A0-A17, BA0-BA1, BG0-BG1, RAS\_n, CAS\_n, WE\_n.
7. C<sub>DI\_CTRL</sub> applies to ODT, CS\_n and CKE
8. C<sub>DI\_CTRL</sub> = C<sub>I(CTRL)</sub>-0.5\*(C<sub>I(CLK\_T)</sub>+C<sub>I(CLK\_C)</sub>)
9. C<sub>DI\_ADD\_CMD</sub> applies to, A0-A17, BA0-BA1, BG0-BG1, RAS\_n, CAS\_n, WE\_n.
10. C<sub>DI\_ADD\_CMD</sub> = C<sub>I(ADD\_CMD)</sub>-0.5\*(C<sub>I(CLK\_T)</sub>+C<sub>I(CLK\_C)</sub>)
11. C<sub>DIO</sub> = C<sub>IO(DQ,DM)</sub>-0.5\*(C<sub>IO(DQS\_T)</sub>+C<sub>IO(DQS\_C)</sub>)
12. Maximum external load capacitance on ZQ pin: tbd pF

## DC and AC Specifications for the SMBus Interface

The specifications for the SMBus follow JEDEC standards.

Datasheet	11/28/2017
PS9MUxx64x8xxx	Viking Technology
Revision C	Page 27 of 41

### Speed Bins by Speed Grade

#### DDR4-1600 Speed Bins and Operating Conditions

Speed Bin			DDR4-1600		Unit	NOTE	
CL-nRCD-nRP			11-11-11				
Parameter	Symbol	Min	Max				
Internal read command to first data	tAA	13.75 <sup>14</sup> (13.50) <sup>5,12</sup>	18	ns			
Internal read command to first data with read DBI enabled	tAA_DBI	tAA(min) + 2nCK	tAA(max) + 2nCK	ns			
ACT to internal read or write delay time	tRCD	13.75 (13.50) <sup>5,12</sup>	-	ns			
PRE command period	tRP	13.75 (13.50) <sup>5,12</sup>	-	ns			
ACT to PRE command period	tRAS	35	9 x tREFI	ns			
ACT to ACT or REF command period	tRC	48.75 (48.50) <sup>5,12</sup>	-	ns			
	Normal	Read DBI					
CWL = 9	CL = 9	CL = 11 (Optional) <sup>5</sup>	tCK(AVG)	Reserved		ns	1,2,3,4,11,14
	CL = 10	CL = 12	tCK(AVG)	1.5	1.6	ns	1,2,3,4,11
CWL = 9,11	CL = 10	CL = 12	tCK(AVG)	Reserved		ns	1,2,3,4
	CL = 11	CL = 13	tCK(AVG)	1.25	<1.5	ns	1,2,3,4
	CL = 12	CL = 14	tCK(AVG)	1.25	<1.5	ns	1,2,3
Supported CL Settings			(9),11,12		nCK	13,14	
Supported CL Settings with read DBI			(11),13,14		nCK	13	
Supported CWL Settings			9,11		nCK		

### DDR4-1866 Speed Bins and Operating Conditions

Speed Bin			DDR4-1866		Unit	NOTE	
CL-nRCD-nRP			13-13-13				
Parameter	Symbol		Min	Max			
Internal read command to first data	tAA		13.92 <sup>14</sup> (13.50) <sup>5,12</sup>	18	ns		
Internal read command to first data with read DBI enabled	tAA_DBI		tAA(min) + 2nCK	tAA(max) + 2nCK	ns		
ACT to internal read or write delay time	tRCD		13.92 (13.50) <sup>5,12</sup>	-	ns		
PRE command period	tRP		13.92 (13.50) <sup>5,12</sup>	-	ns		
ACT to PRE command period	tRAS		34	9 x tREFI	ns		
ACT to ACT or REF command period	tRC		47.92 (47.50) <sup>5,12</sup>	-	ns		
	Normal	Read DBI					
CWL=9	CL=9	CL=11 (Optional) <sup>5</sup>	tCK(AVG)	Reserved		ns	1,2,3,4,11,14
	CL=10	CL=12	tCK(AVG)	1.5	1.6	ns	1,2,3,4,11
CWL=9,11	CL=10	CL=12	tCK(AVG)				4
	CL=11	CL=13	tCK(AVG)	1.25	<1.5	ns	1,2,3,4,6
				(Optional) <sup>5,12</sup>			
CL=12	CL=14	tCK(AVG)	1.25	<1.5	ns	1,2,3,6	
CWL=10,12	CL=12	CL=14	tCK(AVG)	Reserved		ns	1,2,3,4
	CL=13	CL=15	tCK(AVG)	1.071	<1.25	ns	1,2,3,4
	CL=14	CL=16	tCK(AVG)	1.071	<1.25	ns	1,2,3
Supported CL Settings			9,11,12,13,14		nCK	13,14	
Supported CL Settings with read DBI			11,13,14,15,16		nCK	13	
Supported CWL Settings			9,10,11,12		nCK		

### DDR4-2133 Speed Bins and Operating Conditions

Speed Bin			DDR4-2133		Unit	NOTE	
CL-nRCD-nRP			15-15-15				
Parameter	Symbol	Min	Max				
Internal read command to first data	tAA	14.06 <sup>14</sup> (13.75) <sup>5,12</sup>	18		ns		
Internal read command to first data with read DBI enabled	tAA_DBI	tAA(min) + 3nCK	tAA(max) + 3nCK		ns		
ACT to internal read or write delay time	tRCD	14.06 (13.75) <sup>5,12</sup>	-		ns		
PRE command period	tRP	14.06 (13.75) <sup>5,12</sup>	-		ns		
ACT to PRE command period	tRAS	33	9 x tREFI		ns		
ACT to ACT or REF command period	tRC	47.06 (46.75) <sup>5,12</sup>	-		ns		
CWL = 9	Normal	Read DBI	tCK(AVG)	Reserved		ns	1,2,3,4,11,14
	CL = 9	CL = 11 (Optional) <sup>5</sup>					
	CL = 10	CL = 12	tCK(AVG)	1.5	1.6	ns	1,2,3,11
CWL = 9,11	CL = 11	CL = 13	tCK(AVG)			ns	1,2,3,4,7
			tCK(AVG)	(Optional) <sup>5,12</sup>			
	CL = 12	CL = 14	tCK(AVG)	1.25	<1.5	ns	1,2,3,7
CWL = 10,12	CL = 13	CL = 15	tCK(AVG)	1.071	<1.25	ns	1,2,3,4,7
			tCK(AVG)	(Optional) <sup>5,12</sup>			
	CL = 14	CL = 16	tCK(AVG)	1.071	<1.25	ns	1,2,3,7
CWL = 11,14	CL = 14	CL = TBD	tCK(AVG)	Reserved		ns	1,2,3,4
	CL = 15	CL = TBD	tCK(AVG)	0.938	<1.071	ns	1,2,3,4
	CL = 16	CL = TBD	tCK(AVG)	0.938	<1.071	ns	1,2,3
Supported CL Settings			(9),(11),12,(13),14,15,16		nCK	13,14	
Supported CL Settings with read DBI			(11),(13),14,(15),16,18,19		nCK		
Supported CWL Settings			9,10,11,12,14		nCK		

### DDR4-2400 Speed Bins and Operating Conditions

Speed Bin			DDR4-2400		Unit	NOTE	
CL-nRCD-nRP			17-17-17				
Parameter	Symbol	Min	Max				
Internal read command to first data	tAA	14.16 <sup>14</sup> (13.75) <sup>5,12</sup>	18		ns		
Internal read command to first data with read DBI enabled	tAA_DBI	tAA(min) + 3nCK	tAA(max) + 3nCK		ns		
ACT to internal read or write delay time	tRCD	14.16 (13.75) <sup>5,12</sup>	-		ns		
PRE command period	tRP	14.16 (13.75) <sup>5,12</sup>	-		ns		
ACT to PRE command period	tRAS	32	9 x tREFI		ns		
ACT to ACT or REF command period	tRC	46.16 (45.75) <sup>5,12</sup>	-		ns		
							Normal
CWL = 9	CL = 9	CL = 11 (Optional) <sup>5</sup>	tCK(AVG)	Reserved		ns	1,2,3,4,11,14
	CL = 10	CL = 12	tCK(AVG)	1.5	1.6	ns	1,2,3,11
CWL = 9,11	CL = 11	CL = 13	tCK(AVG)			ns	1,2,3,4,7
			tCK(AVG)	(Optional) <sup>5,12</sup>			
CWL = 10,12	CL = 12	CL = 14	tCK(AVG)	1.25	<1.5	ns	1,2,3,7
			tCK(AVG)	(Optional) <sup>5,12</sup>			
CWL = 10,12	CL = 13	CL = 15	tCK(AVG)	1.071	<1.25	ns	1,2,3,4,7
			tCK(AVG)	(Optional) <sup>5,12</sup>			
CWL = 10,12	CL = 14	CL = 16	tCK(AVG)	1.071	<1.25	ns	1,2,3,7
			tCK(AVG)	(Optional) <sup>5,12</sup>			
CWL = 11,14	CL = 14	CL = 17	tCK(AVG)	Reserved		ns	1,2,3,4
	CL = 15	CL = 18	tCK(AVG)	0.938	<1.071	ns	1,2,3,4
	CL = 16	CL = 19	tCK(AVG)	0.938	<1.071	ns	1,2,3
CWL = 12,16	CL = 15	CL = 18	tCK(AVG)	Reserved		ns	1,2,3,4
	CL = 16	CL = 19	tCK(AVG)	Reserved		ns	1,2,3,4
	CL = 17	CL = 20	tCK(AVG)	0.833	<0.938	ns	1,2,3
	CL = 18	CL = 21	tCK(AVG)	0.833	<0.938	ns	1,2,3,4
Supported CL Settings			(10),(11),12,(13),14,15,16,17,18		nCK	13,14	
Supported CL Settings with read DBI			(12),(13),14,(15),16,18,19,20,21		nCK		
Supported CWL Settings			9,10,11,12,14,16		nCK		

### DDR4-2666 Speed Bins and Operating Conditions

Speed Bin		DDR4-2666		Unit	NOTE
CL-nRCD-nRP		22-19-19			
Parameter	Symbol	Min	Max		
Internal read command to first data	tAA	16.5	21.5	ns	
ACT to internal read or write delay time	tRCD	14.25	-	ns	
PRE command period	tRP	14.25	-	ns	
ACT to PRE command period	tRAS	32	9 x tREFI	ns	
ACT to ACT or REF command period	tRC	46.25	-	ns	
CWL = 9,11	CL = 13	tCK(AVG)	Reserved	ns	1,2,3,4,9
CL = 14	tCK(AVG)	1.25	1.5	ns	1,2,3,8
CWL = 10,12	CL = 14	tCK(AVG)	Reserved	ns	1,2,3,4,9
CL = 15	tCK(AVG)	Reserved	ns	1,2,3,4,9	
CL = 16	tCK(AVG)	1.071	<1.25	ns	1,2,3,9
CWL = 11,14	CL = 16	tCK(AVG)	Reserved	ns	1,2,3,4,9
CL = 18	tCK(AVG)	0.937	<1.071	ns	1,2,3,4,9
CL = 20	tCK(AVG)	0.937	<1.071	ns	1,2,3,9
CWL = 12,16	CL = 18	tCK(AVG)	Reserved	ns	1,2,3,4,9
CL = 20	tCK(AVG)	0.833	<0.937	ns	1,2,3,4,9
CL = 22	tCK(AVG)	0.833	<0.937	ns	1,2,3,9
CWL = 14,18	CL = 20	tCK(AVG)	Reserved	ns	1,2,3,4,9
CL = 22	tCK(AVG)	0.75	0.833	ns	1,2,3,4,9
CL = 24	tCK(AVG)	0.75	0.833	ns	1,2,3,9
Supported CL Settings	11,12,13,14,15,16,17,18,19,20,22,24	nCK			
Supported nRCD Timings minimum	12	nCK			
Supported nRP Timings minimum	12	nCK			
Supported CWL Settings	9,10,11,12,14,16,18	nCK			

### Timing Parameters by Speed Grade

Speed		DDR4-1600		DDR4-1866		DDR4-2133		Units	Note
Parameter	Symbol	MIN	MAX	MIN	MAX	MIN	MAX		
<b>Clock Timing</b>									
Minimum Clock Cycle Time (DLL off mode)	tCK(DLL_OFF)	8	-	8	-	8	-	ns	23
Average Clock Period	tCK(avg)	See Speed Bins Table						ps	
Average high pulse width	tCH(avg)	0.48	0.52	0.48	0.52	0.48	0.52	tCK(avg)	
Average low pulse width	tCL(avg)	0.48	0.52	0.48	0.52	0.48	0.52	tCK(avg)	
Absolute Clock Period	tCK(abs)	tCK(avg)min + tJIT(per)min_tot	tCK(avg)max + tJIT(per)max_tot	tCK(avg)min + tJIT(per)min_tot	tCK(avg)max + tJIT(per)max_tot	tCK(avg)min + tJIT(per)min_tot	tCK(avg)max + tJIT(per)max_tot	tCK	
Absolute clock HIGH pulse width	tCH(abs)	0.45	-	0.45	-	0.45	-	tCK(avg)	24

Datasheet	11/28/2017
PS9MUxx64x8xxx	Viking Technology
Revision C	Page 32 of 41



Speed		DDR4-1600		DDR4-1866		DDR4-2133		Units	Note
Parameter	Symbol	MIN	MAX	MIN	MAX	MIN	MAX		
Absolute clock Low pulse width	tCL(abs)	0.45	-	0.45	-	0.45	-	tCK(avg)	25
Clock Period Jitter- total	JIT(per)_tot	-0.1	0.1	-0.1	0.1	-0.1	0.1	UI	26
Clock Period Jitter-deterministic	JIT(per)_dj	tbd						UI	27
Clock Period Jitter during DLL locking period	tJIT(per, lck)	tbd						UI	
Cycle to Cycle Period Jitter	tJIT(cc)_tot	0.2		0.2		0.2		UI	26
Cycle to Cycle Period Jitter-deterministic	tJIT(cc)_dj	tbd						UI	27
Cycle to Cycle Period Jitter during DLL locking period	tJIT(cc, lck)	tbd						UI	
Duty cycle Jitter	tJIT(duty)	tbd						UI	
Cumulative error across 2 cycles	tERR(2per)	tbd						UI	
Cumulative error across 3 cycles	tERR(3per)	tbd						UI	
Cumulative error across 4 cycles	tERR(4per)	tbd						UI	
Cumulative error across 5 cycles	tERR(5per)	tbd						UI	
Cumulative error across 6 cycles	tERR(6per)	tbd						UI	
Cumulative error across 7 cycles	tERR(7per)	tbd						UI	
Cumulative error across 8 cycles	tERR(8per)	tbd						UI	
Cumulative error across 9 cycles	tERR(9per)	tbd						UI	
Cumulative error across 10 cycles	tERR(10per)	tbd						UI	
Cumulative error across 11 cycles	tERR(11per)	tbd						UI	
Cumulative error across 12 cycles	tERR(12per)	tbd						UI	
Cumulative error across n = 13, 14 ... 49, 50 cycles	tERR(nper)	tbd						UI	
<b>Command and Address Timing</b>									
CAS_n to CAS_n command delay for same bank group	tCCD_L	5	-	5	-	6	-	nCK	
CAS_n to CAS_n command delay for different bank group	tCCD_S	4	-	4	-	4	-	nCK	
ACTIVATE to ACTIVATE Command delay to different bank group for 2KB page size	tRRD_S(2K)	Max(4nCK,6ns)	-	Max(4nCK,5.3ns)	-	Max(4nCK,5.3ns)	-	nCK	
ACTIVATE to ACTIVATE Command delay to different bank group for 1KB page size	tRRD_S(1K)	Max(4nCK,5ns)	-	Max(4nCK,4.2ns)	-	Max(4nCK,3.7ns)	-	nCK	
ACTIVATE to ACTIVATE Command delay to different bank group for 1/2KB page size	tRRD_S(1/2K)	Max(4nCK,5ns)	-	Max(4nCK,4.2ns)	-	Max(4nCK,3.7ns)	-	nCK	
ACTIVATE to ACTIVATE Command delay to same bank group for 2KB page size	tRRD_L(2K)	Max(4nCK,7.5ns)	-	Max(4nCK,6.4ns)	-	Max(4nCK,6.4ns)	-	nCK	
ACTIVATE to ACTIVATE Command delay to same bank group for 1KB page size	tRRD_L(1K)	Max(4nCK,6ns)	-	Max(4nCK,5.3ns)	-	Max(4nCK,5.3ns)	-	nCK	
ACTIVATE to ACTIVATE Command delay to same bank group for 1/2KB page size	tRRD_L(1/2K)	Max(4nCK,6ns)	-	Max(4nCK,5.3ns)	-	Max(4nCK,5.3ns)	-	nCK	
Four activate window for 2KB page size	tFAW_2K	35		30		30		ns	
Four activate window for 1KB page size	tFAW_1K	25		23		21		ns	
Four activate window for 1/2KB page size	tFAW_1/2K	20		17		15		ns	
Delay from start of internal write transaction to internal read command for different bank group	tWTR_S	max(2nCK,2.5ns)	-	max(2nCK,2.5ns)	-	max(2nCK,2.5ns)	-		1,2,e
Delay from start of internal write transaction to internal read command for same bank group	tWTR_L	max(4nCK,7.5ns)	-	max(4nCK,7.5ns)	-	max(4nCK,7.5ns)	-		1
Internal READ Command to PRECHARGE Command delay	tRTP	max(4nCK,7.5ns)	-	max(4nCK,7.5ns)	-	max(4nCK,7.5ns)	-		
WRITE recovery time	tWR	15	-	15	-	15	-	ns	1

Speed		DDR4-1600		DDR4-1866		DDR4-2133		Units	Note
Parameter	Symbol	MIN	MAX	MIN	MAX	MIN	MAX		
WRITE recovery time when CRC and DM are enabled	tWR_CRC_DM	tWR+max(4nCK,3.75ns)	-	tWR+max(5nCK,3.75ns)	-	tWR+max(5nCK,3.75ns)	-	ns	1,29
Delay from start of internal write transaction to internal read command for different bank groups with both CRC and OM enabled	tWTR_S_CRC_DM	tWTR_S+max(4nCK,3.75ns)	-	tWTR_S+max(5nCK,3.75ns)	-	tWTR_S+max(5nCK,3.75ns)	-	ns	2,30
Delay from start of internal write transaction to internal read command for same bank group with both CRC and OM enabled	tWTR_L_CRC_DM	tWTR_L+max(4nCK,3.75ns)	-	tWTR_L+max(5nCK,3.75ns)	-	tWTR_L+max(5nCK,3.75ns)	-	ns	3,31
DLL locking time	tDLLK	TBD						nCK	
Mode Register Set command cycle time	tMRD	8	-	8	-	8	-	nCK	
Mode Register Set command update delay	tMOD	max(24nCK,15ns)	-	max(24nCK,15ns)	-	max(24nCK,15ns)	-		
Multi-Purpose Register Recovery Time	tMPRR	1	-	1	-	1	-	nCK	
Multi-Purpose Register Write Recovery Time	tWR_MPR	tMOD (min)	-	tMOD (min)	-	tMOD (min)	-		
<b>CS_n to Command Address Latency</b>									
CS_n to Command Address Latency	tCAL	3	-	4	-	4	-	nCK	
<b>DRAM Data Timing</b>									
DQS_t,DQS_c to DQ skew, per group, per access	tDQSQ	-	tbd	-	tbd	-	tbd	tCK(avg)/2	14,1,9
DQS_t,DQS_c to DQ skew deterministic, per group, per access	tDQSQ	-	tbd	-	tbd	-	tbd	tCK(avg)/2	15,1,7,19
DQ output hold time from DQS_t,DQS_c	tQH	tbd	-	-	-	-	-	tCK(avg)/2	14,1,8,19
DQ output hold time deterministic from DQS_t, DQS_c	tQH	tbd	-	-	-	-	-	UI	15,1,7,19
DQS_t,DQS_c to DQ Skew total, per group, per access; DBI enabled	tDQSQ	-	tbd	-	tbd	-	tbd	UI	14,20
DQ output hold time total from DQS_t, DQS_c; DBI enabled	tQH	TBD	-	TBD	-	TBD	-	UI	14,20
DQ to DQ offset, per group, per access referenced to DQS_t, DQS_c	tDQSQ	TBD	TBD	TBD	TBD	TBD	TBD	UI	16,17
<b>Data Strobe Timing</b>									
DQS_t,DQS_c differential output high time	tQSH	TBD	TBD	TBD	TBD	TBD	TBD	tCK(avg)/2	22
DQS_t,DQS_c differential output low time	tQSL	TBD	TBD	TBD	TBD	TBD	TBD	tCK(avg)/2	21
<b>MPSM Timing</b>									
Command path disable delay upon MPSM entry	tMPED	tMOD(min) + tCPDED(min)	-	tMOD(min) + tCPDED(min)	-	tMOD(min) + tCPDED(min)	-		
Valid clock requirement after MPSM entry	tCKMPE	tMOD(min) + tCPDED(min)	-	tMOD(min) + tCPDED(min)	-	tMOD(min) + tCPDED(min)	-		
Valid clock requirement before MPSM exit	tCKMPX	tCKSRX(min)	-	tCKSRX(min)	-	tCKSRX(min)	-		
Exit MPSM to commands not requiring a locked DLL	tXMP	TBD	-	TBD	-	TBD	-		
Exit MPSM to commands requiring a locked DLL	tXMPDLL	tXMP(min) + tXSDLL(min)	-	tXMP(min) + tXSDLL(min)	-	tXMP(min) + tXSDLL(min)	-		
CS setup time to CKE	tMPX_S	TBD	-	TBD	-	TBD	-		
CS hold time to CKE	tMPX_H	TBD	-	TBD	-	TBD	-		
<b>Calibration Timing</b>									
Power-up and RESET calibration time	tZQinit	1024	-	1024	-	1024	-	nCK	
Normal operation Full calibration time	tZQoper	512	-	512	-	512	-	nCK	
Normal operation Short calibration time	tZQCS	128	-	128	-	128	-	nCK	
<b>Reset/Self Refresh Timing</b>									
Exit Reset from CKE HIGH to a valid command	tXPR	max (5nCK,tRFC(min) + 10ns)	-	max (5nCK,tRFC(min) + 10ns)	-	max (5nCK,tRFC(min) + 10ns)	-		
Exit Self Refresh to commands not requiring a locked DLL	tXS	tRFC(min)+10ns	-	tRFC(min)+10ns	-	tRFC(min)+10ns	-		
SRX to commands not requiring a locked DLL in Self Refresh ABORT	tXS_ABORT(min)	tRFC4(min)+10ns	-	tRFC4(min)+10ns	-	tRFC4(min)+10ns	-		

Speed		DDR4-1600		DDR4-1866		DDR4-2133		Units	Note
Parameter	Symbol	MIN	MAX	MIN	MAX	MIN	MAX		
Exit Self Refresh to ZOCL, ZQCS and MRS (CL, CWL, WR, RTP and Gear Down)	tXS_FAST (min)	tRFC4(min)+10ns	-	tRFC4(min)+10ns	-	tRFC4(min)+10ns	-		
Exit Self Refresh to commands requiring a locked DLL	tXSDLL	tDLLK(min)	-	tDLLK(min)	-	tDLLK(min)	-		
Minimum CKE low width for Self refresh entry to exit timing	tCKESR	tCKE(min)+1nCK	-	tCKE(min)+1nCK	-	tCKE(min)+1nCK	-		
Valid Clock Requirement after Self Refresh Entry (SRE) or Power-Down Entry (PDE)	tCKSRE	max(5nCK, 10ns)	-	max(5nCK, 10ns)	-	max(5nCK, 10ns)	-		
Valid Clock Requirement after Self Refresh Entry (SRE) or Power-Down when CA Parity is enabled	tCKSRE_PAR	max (5nCK, 10ns)+PL	-	max (5nCK, 10ns)+PL	-	max (5nCK, 10ns)+PL	-		
Valid Clock Requirement before Self Refresh Exit (SRX) or Power-Down Exit (PDX) or Reset Exit	tCKSRX	max(5nCK, 10ns)	-	max(5nCK, 10ns)	-	max(5nCK, 10ns)	-		
<b>Power Down Timing</b>									
Exit Power Down with DLL on to any valid command; Exit Precharge Power Down with DLL frozen t commands not requiring a locked DLL	tXP	max (4nCK, 6ns)	-	max (4nCK, 6ns)	-	max (4nCK, 6ns)	-		
Exit Precharge Power Down with DLL frozen to commands requiring a locked DLL	tXPDLL	max (10nCK, 24ns)	-	max (10nCK, 24ns)	-	max (10nCK, 24ns)	-		3
CKE minimum pulse width	tCKE	max (3nCK, 5ns)	-	max (3nCK, 5ns)	-	max (3nCK, 5ns)	-		32,33
Command pass disable delay	tCPDED	4	-	4	-	4	-		
Power Down Entry to Exit Timing	tPD	tCKE(min)	9*tREFI	tCKE(min)	9*tREFI	tCKE(min)	9*tREFI		6
Timing of ACT command to Power Down entry	tACTPDEN	1	-	1	-	2	-		7
Timing of PRE or PREA command to Power Down entry	tPRPDEN	1	-	1	-	2	-		7
Timing of RD/RDA command to Power Down entry	tRDPDEN	RL+4+1	-	RL+4+1	-	RL+4+1	-	nCK	
Timing of WR command to Power Down entry (BL8OTF, BL8MRS, BC4OTF)	tWRPDEN	WL+4+(tWR/ tCK(avg))	-	WL+4+(tWR/ tCK(avg))	-	WL+4+(tWR/ tCK(avg))	-	nCK	4
Timing of WRA command to Power Down entry (BL8OTF, BL8MRS, BC4OTF)	tWRAPDEN	WL+4+WR+1	-	WL+4+WR+1	-	WL+4+WR+1	-	nCK	5
Timing of WR command to Power Down entry (BC4MRS)	tWRPBC4DEN	WL+2+(tWR/ tCK(avg))	-	WL+2+(tWR/ tCK(avg))	-	WL+2+(tWR/ tCK(avg))	-	nCK	4
Timing of WRA command to Power Down entry (BC4MRS)	tWRAPBC4DEN	WL+2+WR+1	-	WL+2+WR+1	-	WL+2+WR+1	-	nCK	5
Timing of REF command to Power Down entry	tREFPDEN	1	-	1	-	2	-	nCK	7,8
Timing of MRS command to Power Down entry	tMRSPDEN	tMOD(min)	-	tMOD(min)	-	tMOD(min)	-		
<b>PDA Timing</b>									
Mode Register Set command cycle time in PDA mode	tMRD_PDA	max(16nCK, 10ns)	-	max(16nCK, 10ns)	-	max(16nCK, 10ns)	-		
Mode Register Set command update delay in PDA mode	tMOD_PDA	tMOD		tMOD		tMOD			
<b>ODT Timing</b>									
Asynchronous RTT turn-on delay (Power-Down with DLL frozen)	tAONAS	1	9	1	9	1	9	ns	
Asynchronous RTT turn-off delay (Power-Down with DLL frozen)	tAOFAS	1	9	1	9	1	9	ns	
RTT dynamic change skew	tADC	0.3	0.7	0.3	0.7	0.3	0.7	tCK(avg)	
<b>Write Leveling Timing</b>									
First DQS $\uparrow$ /DQS $\downarrow$ rising edge after write leveling mode is programmed	tWLMRD	40	-	40	-	40	-	nCK	13
DQS $\uparrow$ /DQS $\downarrow$ delay after write leveling mode is programmed	tWLDQSEN	25	-	25	-	25	-	nCK	13
Write leveling setup time from rising CK $\uparrow$ , CK $\downarrow$ crossing to rising DQS $\uparrow$ /DQS $\downarrow$ crossing	tWLS	0.13	-	0.13	-	0.13	-	tCK(avg)	

Speed		DDR4-1600		DDR4-1866		DDR4-2133		Units	Note
Parameter	Symbol	MIN	MAX	MIN	MAX	MIN	MAX		
Write leveling hold time from rising DQS_1/DQS_n crossing to rising CK_t, CK_crossing	tWLH	0.13	-	0.13	-	0.13	-	tCK(avg)	
Write leveling output delay	tWLO	0	9.5	0	9.5	0	9.5	ns	
Write leveling output error	tWLOE							ns	
<b>CA Parity Timing</b>									
Commands not guaranteed to be executed during this time	tPAR_UNKNOWN	-	Max(2nCK,3ns)	-	Max(2nCK,3ns)	-	Max(2nCK,3ns)		
Delay from errant command to ALERT_n assertion	tPAR_ALERT_ON	-	PL+6ns	-	PL+6ns	-	PL+6ns		
Pulse width of ALERT_n signal when asserted	tPAR_ALERT_PW	48	96	56	112	64	128	nCK	
Time from when Alert is asserted till controller must start providing DES commands in Persistent CA parity mode	tPAR_ALERT_RSP	-	43	-	50	-	57	nCK	
Parity Latency [ 1715.64, JC42.3C]	PL	4		4		4		nCK	
<b>CRC Error Reporting</b>									
CRC error to ALERT_n latency	tCRC_ALERT	-	13	-	13	-	13	ns	
CRC ALERT_n pulse width	CRC_ALERT_PW	6	10	6	10	6	10	nCK	
Write recovery time when CRC and DM are enabled	tWR_CRC_DM	tWR+max (4nCK,3.75ns)	-	tWR+max (5nCK,3.75ns)	-	tWR+max (5nCK,3.75ns)	-	ns	10
delay from start of internal write transaction to internal delay from start of internal read command for different bank group with both CRC and DM enabled	tWTR_S_C RC_DM	tWTR_S+max (4nCK,3.75ns)	-	tWTR_S+max (5nCK,3.75ns)	-	tWTR_S+max (5nCK,3.75ns)	-	ns	11
delay from start of internal write transaction to internal delay from start of internal read command for same bank group with both CRC and DM enabled	tWTR_L_C RC_DM	tWTR_L+max (4nCK,3.75ns)	-	tWTR_L+max (5nCK,3.75ns)	-	tWTR_L+max (5nCK,3.75ns)	-	ns	12
<b>Geardown timing</b>									
Exit RESET from CKE HIGH to a valid MRS geardown (T2/Reset)	tXPR_GEAR	tXPR		tXPR					
CKE HIGH Assert Geardown Enable time(T2/CKE)	tXS_GEAR	tXS		tXS					
MRS command to Sync pulse time(T3)	tSYNC_GEAR	tMOD(min)+4nCK		tMOD(min)+4nCK					28
Sync pulse to First valid command(T4)	tCMD_GEAR								28
Geardown setup time	tGEAR_setup							nCK	
Geardown hold time	tGEAR_hold							nCK	
<b>tREFI</b>									
tRFC1 (min)	2Gb	160	-	160	-	160	-	ns	
	4Gb	260	-	260	-	260	-	ns	
	8Gb	350	-	350	-	350	-	ns	
	16Gb	TBD by JEDEC board spec)	-	TBD	-	TBD	-	ns	
tRFC2 (min)	2Gb	110	-	110	-	110	-	ns	
	4Gb	160	-	160	-	160	-	ns	
	8Gb	260	-	260	-	260	-	ns	
	16Gb	TBD by JEDEC board spec)	-	TBD	-	TBD	-	ns	
tRFC4 (min)	2Gb	90	-	90	-	90	-	ns	
	4Gb	110	-	110	-	110	-	ns	
	8Gb	160	-	160	-	160	-	ns	
	16Gb	TBD by JEDEC board spec)	-	TBD	-	TBD	-	ns	

## Timing Parameters by Speed Grade, continued

Speed		DDR4-2400		DDR4-2667		DDR4-3200		Units	Note
Parameter	Symbol	MIN	MAX	MIN	MAX	MIN	MAX		
<b>Clock Timing</b>									
Minimum Clock Cycle Time (DLL off mode)	tCK(DLL_OFF)	8	-	8	-	8	-	ns	23
Average Clock Period	tCK(avg)	See Speed Bins Table						ps	
Average high pulse width	tCH(avg)	0.48	0.52	0.48	0.52	0.48	0.52	tCK(avg)	
Average low pulse width	tCL(avg)	0.48	0.52	0.48	0.52	0.48	0.52	tCK(avg)	
Absolute Clock Period	tCK(abs)	tCK(avg)min + tJIT(per)min_tot	tCK(avg)max + tJIT(per)max_tot	tCK(avg)min + tJIT(per)min_tot	tCK(avg)max + tJIT(per)max_tot	tCK(avg)min + tJIT(per)min_tot	tCK(avg)max + tJIT(per)max_tot	tCK	
Absolute clock HIGH pulse width	tCH(abs)	0.45	-	0.45	-	0.45	-	tCK(avg)	24
Absolute clock Low pulse width	tCL(abs)	0.45	-	0.45	-	0.45	-	tCK(avg)	25
Clock Period Jitter- total	JIT(per)_tot	-42	42	-0.1	0.1	-0.1	0.1	UI	26
Clock Period Jitter- deterministic	JIT(per)_dj	tdb						UI	27
Clock Period Jitter during DLL locking period	tJIT(per, lck)	tdb						UI	
Cycle to Cycle Period Jitter	tJIT(cc)_tot	83		0.2		0.2		UI	26
Cycle to Cycle Period Jitter- deterministic	tJIT(cc)_dj	tdb						UI	27
Cycle to Cycle Period Jitter during DLL locking period	tJIT(cc, lck)	tdb						UI	
Duty cycle Jitter	tJIT(duty)	tdb						UI	
Cumulative error across 2 cycles	tERR(2per)	tdb						UI	
Cumulative error across 3 cycles	tERR(3per)	tdb						UI	
Cumulative error across 4 cycles	tERR(4per)	tdb						UI	
Cumulative error across 5 cycles	tERR(5per)	tdb						UI	
Cumulative error across 6 cycles	tERR(6per)	tdb						UI	
Cumulative error across 7 cycles	tERR(7per)	tdb						UI	
Cumulative error across 8 cycles	tERR(8per)	tdb						UI	
Cumulative error across 9 cycles	tERR(9per)	tdb						UI	
Cumulative error across 10 cycles	tERR(10per)	tdb						UI	
Cumulative error across 11 cycles	tERR(11per)	tdb						UI	
Cumulative error across 12 cycles	tERR(12per)	tdb						UI	
Cumulative error across n = 13, 14 ... 49, 50 cycles	tERR(nper)	tdb						UI	
<b>Command and Address Timing</b>									
CAS_n to CAS_n command delay for same bank group	tCCD_L	6	-	tdb	-	-	-	nCK	
CAS_n to CAS_n command delay for different bank group	tCCD_S	4	-	4	-	-	-	nCK	
ACTIVATE to ACTIVATE Command delay to different bank group for 2KB page size	tRRD_S(2K)	Max(4nCK, 5.3ns)	-		-	-	-	nCK	
ACTIVATE to ACTIVATE Command delay to different bank group for 1KB page size	tRRD_S(1K)	Max(4nCK, 3.3ns)	-		-	-	-	nCK	
ACTIVATE to ACTIVATE Command delay to different bank group for 1/2KB page size	tRRD_S(1/2K)	Max(4nCK, 3.3ns)	-		-	-	-	nCK	
ACTIVATE to ACTIVATE Command delay to same bank group for 2KB page size	tRRD_L(2K)	Max(4nCK, 6.4ns)	-		-	-	-	nCK	
ACTIVATE to ACTIVATE Command delay to same bank group for 1KB page size	tRRD_L(1K)	Max(4nCK, 4.9ns)	-		-	-	-	nCK	
ACTIVATE to ACTIVATE Command delay to same bank group for 1/2KB page size	tRRD_L(1/2K)	Max(4nCK, 4.9ns)	-		-	-	-	nCK	
Four activate window for 2KB page size	tFAW_2K	30						ns	

Speed		DDR4-2400		DDR4-2667		DDR4-3200		Units	Note
Parameter	Symbol	MIN	MAX	MIN	MAX	MIN	MAX		
Four activate window for 1KB page size	tFAW_1K	21						ns	
Four activate window for 1KB page size	tFAW_1/2K	13						ns	
Delay from start of internal write transaction to internal read command for different bank group	tWTR_S	max(2nCK,2.5ns)	-		-		-		1,2,e
Delay from start of internal write transaction to internal read command for same bank group	tWTR_L	max(4nCK,7.5ns)	-		-		-		1
Internal READ Command to PRECHARGE Command delay	tRTP	max(4nCK,7.5ns)	-		-		-		
WRITE recovery time	tWR	15	-		-		-	ns	1
WRITE recovery time when CRC and DM are enabled	tWR_CRC_DM	tWR+max(5nCK,3.75ns)	-		-		-	ns	1,29
Delay from start of internal write transaction to internal read command for different bank groups with both CRC and OM enabled	tWTR_S_CRC_DM	tWTR_S+max(5nCK,3.75ns)	-		-		-	ns	2,30
Delay from start of internal write transaction to internal read command for same bank group with both CRC and OM enabled	tWTR_L_CRC_DM	tWTR_L+max(5nCK,3.75ns)	-		-		-	ns	3,31
DLL locking time	tDLLK	TBD						nCK	
Mode Register Set command cycle time	tMRD	8	-		-		-	nCK	
Mode Register Set command update delay	tMOD	max(24nCK,15ns)	-		-		-		
Multi-Purpose Register Recovery Time	tMPRR	1	-		-		-	nCK	
Multi-Purpose Register Write Recovery Time	tWR_MPR	tMOD (min) + AL + PL	-		-		-		
<b>CS_n to Command Address Latency</b>									
CS_n to Command Address Latency	tCAL	5	-		-		-	nCK	
<b>DRAM Data Timing</b>									
DQS_t,DQS_c to DQ skew, per group, per access	tDQSQ	-	tbd	-	tbd	-	tbd	tCK(avg)/2	14,1,9
DQS_t,DQS_c to DQ skew deterministic, per group, per access	tDQSQ	-	tbd	-	tbd	-	tbd	tCK(avg)/2	15,1,7,19
DQ output hold time from DQS_t,DQS_c	tQH	tbd	-		-		-	tCK(avg)/2	14,1,8,19
DQ output hold time deterministic from DQS_t, DQS_c	tQH	tbd	-		-		-	UI	15,1,7,19
DQS_t,DQS_c to DQ Skew total, per group, per access; DBI enabled	tDQSQ	-	tbd	-	tbd	-	tbd	UI	14,20
DQ output hold time total from DQS_t, DQS_c; DBI enabled	tQH	TBD	-	TBD	-	TBD	-	UI	14,20
DQ to DQ offset , per group, per access refer-enced to DQS_t, DQS_c	tDQSQ	TBD	TBD	TBD	TBD	TBD	TBD	UI	16, 17
<b>Data Strobe Timing</b>									
DQS_t,DQS_c differential output high time	tQSH	TBD	TBD	TBD	TBD	TBD	TBD	tCK(avg)/2	22
DQS_t,DQS_c differential output low time	tQSL	TBD	TBD	TBD	TBD	TBD	TBD	tCK(avg)/2	21
<b>MPSM Timing</b>									
Command path disable delay upon MPSM entry	tMPED	tMOD(min) + tCPDED(min)	-				-		
Valid clock requirement after MPSM entry	tCKMPE	tMOD(min) + tCPDED(min)	-				-		
Valid clock requirement before MPSM exit	tCKMPX	tCKSRX(min)	-				-		
Exit MPSM to commands not requiring a locked DLL	tXMP	TBD	-				-		
Exit MPSM to commands requiring a locked DLL	tXMPDLL	tXMP(min) + tXSDDL(min)	-				-		
CS setup time to CKE	tMPX_S	TBD	-				-		
CS hold time to CKE	tMPX_H	TBD	-				-		
<b>Calibration Timing</b>									
Power-up and RESET calibration time	tZQinit	1024	-				-	nCK	
Normal operation Full calibration time	tZQoper	512	-				-	nCK	

Speed		DDR4-2400		DDR4-2667		DDR4-3200		Units	Note
Parameter	Symbol	MIN	MAX	MIN	MAX	MIN	MAX		
Normal operation Short calibration time	tZQCS	128	-				-	nCK	
<b>Reset/Self Refresh Timing</b>									
Exit Reset from CKE HIGH to a valid command	tXPR	max(5nCK,tRFC(min)+10ns)	-				-		
Exit Self Refresh to commands not requiring a locked DLL	tXS	tRFC(min)+10ns	-				-		
SRX to commands not requiring a locked DLL in Self Refresh ABORT	tXS_ABORT(min)	tRFC4(min)+10ns	-				-		
Exit Self Refresh to ZQCL,ZQCS and MRS (CL,CWL,WR,RTP and Gear Down)	tXS_FAST (min)	tRFC4(min)+10ns	-				-		
Exit Self Refresh to commands requiring a locked DLL	tXSDLL	tDLL(min)	-				-		
Minimum CKE low width for Self refresh entry to exit timing	tCKESR	tCKE(min)+1nCK	-				-		
Valid Clock Requirement after Self Refresh Entry (SRE) or Power-Down Entry (PDE)	tCKSRE	max(5nCK,10ns)	-				-		
Valid Clock Requirement after Self Refresh Entry (SRE) or Power-Down when CA Parity is enabled	tCKSRE_PAR	max(5nCK,10ns)+PL	-				-		
Valid Clock Requirement before Self Refresh Exit (SRX) or Power-Down Exit (PDX) or Reset Exit	tCKSRX	max(5nCK,10ns)	-				-		
<b>Power Down Timing</b>									
Exit Power Down with DLL on to any valid command; Exit Precharge Power Down with DLL frozen t commands not requiring a locked DLL	tXP	max(4nCK,6ns)	-				-		
Exit Precharge Power Down with DLL frozen to commands requiring a locked DLL	tXPDLL	max(10nCK,24ns)	-				-		3
CKE minimum pulse width	tCKE	max(3nCK,5ns)	-				-		32,33
Command pass disable delay	tCPDED	4	-				-		
Power Down Entry to Exit Timing	tPD	tCKE(min)	9*tREFI				9*tREFI		6
Timing of ACT command to Power Down entry	tACTPDEN	2	-				-		7
Timing of PRE or PREA command to Power Down entry	tPRPDEN	2	-				-		7
Timing of RD/RDA command to Power Down entry	tRDPDEN	RL+4+1	-				-	nCK	
Timing of WR command to Power Down entry (BL8OTF, BL8MRS, BC4OTF)	tWRPDEN	WL+4+(tWR/ tCK(avg))	-				-	nCK	4
Timing of WRA command to Power Down entry (BL8OTF, BL8MRS, BC4OTF)	tWRAPDEN	WL+4+WR+1	-				-	nCK	5
Timing of WR command to Power Down entry (BC4MRS)	tWRPBC4DEN	WL+2+(tWR/ tCK(avg))	-				-	nCK	4
Timing of WRA command to Power Down entry (BC4MRS)	tWRAPBC4DEN	WL+2+WR+1	-				-	nCK	5
Timing of REF command to Power Down entry	tREFPDEN	2	-				-	nCK	7,8
Timing of MRS command to Power Down entry	tMRSPDEN	tMOD(min)	-				-		
<b>PDA Timing</b>									
Mode Register Set command cycle time in PDA mode	tMRD_PDA	max(16nCK,10ns)	-	max(16nCK,10ns)	-	max(16nCK,10ns)	-		
Mode Register Set command update delay in PDA mode	tMOD_PDA	tMOD		tMOD		tMOD			
<b>ODT Timing</b>									
Asynchronous RTT turn-on delay (Power-Down with DLL frozen)	tAONAS	1	9					ns	
Asynchronous RTT turn-off delay (Power-Down with DLL frozen)	tAOFAS	1	9					ns	
RTT dynamic change skew	tADC	0.3	0.7					tCK(avg)	
<b>Write Leveling Timing</b>									
First DQS_t/DQS_n rising edge after write leveling mode is programmed	tWLMRD	40	-					nCK	13
DQS_t/DQS_n delay after write leveling mode is programmed	tWLDQSEN	25	-					nCK	13

Speed		DDR4-2400		DDR4-2667		DDR4-3200		Units	Note
Parameter	Symbol	MIN	MAX	MIN	MAX	MIN	MAX		
Write leveling setup time from rising CK_t, CK_c crossing to rising DQS, t/DQS_n crossing	tWLS	0.13	-					tCK(avg)	
Write leveling hold time from rising DQS, t/DQS_n crossing to rising CK_t, CK_c crossing	tWLH	0.13	-					tCK(avg)	
Write leveling output delay	tWLO	0	9.5					ns	
Write leveling output error	tWLOE							ns	
<b>CA Parity Timing</b>									
Commands not guaranteed to be executed during this time	tPAR_UNKNOWN	-	Max(2nCK,3ns)						
Delay from errant command to ALERT_n assertion	tPAR_ALERT_ON	-	PL+6ns						
Pulse width of ALERT_n signal when asserted	tPAR_ALERT_PW	72	144					nCK	
Time from when Alert is asserted till controller must start providing DES commands in Persistent CA parity mode	tPAR_ALERT_RSP	-	64					nCK	
Parity Latency [ 1715.64, JC42.3C]	PL	5						nCK	
<b>CRC Error Reporting</b>									
CRC error to ALERT_n latency	tCRC_ALERT	-	13					ns	
CRC ALERT_n pulse width	CRC_ALERT_PW	6	10					nCK	
Write recovery time when CRC and DM are enabled	tWR_CRC_DM	tWR+max (5nCK,3.75ns)						ns	10
delay from start of internal write transaction to internal delay from start of internal write transaction to internal read command for different bank group with both CRC and DM enabled	tWTR_S_C RC_DM	tWTR_S+max (5nCK,3.75ns)						ns	11
delay from start of internal write transaction to internal delay from start of internal write transaction to internal read command for same bank group with both CRC and DM enabled	tWTR_L_C RC_DM	tWTR_L+max (5nCK,3.75ns)						ns	12
<b>Geardown timing</b>									
Exit RESET from CKE HIGH to a valid MRS geardown (T2/Reset)	tXPR_GEAR	tXPR		tXPR					
CKE HIGH Assert Geardown Enable time(T2/CKE)	tXS_GEAR	tXS		tXS					
MRS command to Sync pulse time(T3)	tSYNC_GEAR	tMOD(min)+4nCK		tMOD(min)+4nCK					28
Sync pulse to First valid command(T4)	tCMD_GEAR			tMOD		tMOD			28
Geardown setup time	tGEAR_setup			2	-	2	-	nCK	
Geardown hold time	tGEAR_hold			2	-	2	-	nCK	
<b>tREFI</b>									
tRFC1 (min)	2Gb	160	-	160	-	160	-	ns	
	4Gb	260	-	260	-	260	-	ns	
	8Gb	350	-	350	-	350	-	ns	
	16Gb	TBD by JEDEC board spec)	-	TBD	-	TBD	-	ns	
tRFC2 (min)	2Gb	110	-	110	-	110	-	ns	
	4Gb	160	-	160	-	160	-	ns	
	8Gb	260	-	260	-	260	-	ns	
	16Gb	TBD by JEDEC board spec)	-	TBD	-	TBD	-	ns	
tRFC4 (min)	2Gb	90	-	90	-	90	-	ns	
	4Gb	110	-	110	-	110	-	ns	
	8Gb	160	-	160	-	160	-	ns	
	16Gb	TBD by JEDEC board spec)	-	TBD	-	TBD	-	ns	

**Notes:**

- Start of internal write transaction is defined as follows:  
 For BL8 (Fixed by MRS and on-the-fly): Rising clock edge 4 clock cycles after WL.  
 For BC4 (on-the-fly): Rising clock edge 4 clock cycles after WL.  
 For BC4 (fixed by MRS): Rising clock edge 2 clock cycles after WL.
- A separate timing parameter will cover the delay from write to read when CRC and DM are simultaneously enabled
- Commands requiring a locked DLL are: READ (and RAP) and synchronous ODT commands.
- tWR is defined in ns, for calculation of tWRPDEN it is necessary to round up tWR/tCK to the next integer.
- WR in clock cycles as programmed in MR0.
- tREFI depends on TOPER.
- CKE is allowed to be registered low while operations such as row activation, precharge, autoprecharge or refresh are in progress, but power-down IDD spec will not be applied until finishing those operations.
- Although CKE is allowed to be registered LOW after a REFRESH command once tREFPDEN(min) is satisfied, there are cases where additional time such as tXPDLL(min) is also required. See 0.1.3 "Power-Down clarifications - Case 2" in RB11112 .

Datasheet	11/28/2017
PS9MUxx64x8xxx	Viking Technology
Revision C	Page 40 of 41



- DQ Receiver(Rx) compliance mask
- 9. For these parameters, the DDR4 SDRAM device supports  $t_{nPARAM}[nCK]=RU\{t_{PARAM}[ns]/t_{CK}(avg)[ns]\}$ , which is in clock cycles assuming all input clock jitter specifications are satisfied
- 10. When CRC and DM are both enabled,  $t_{WR\_CRC\_DM}$  is used in place of  $t_{WR}$ .
- 11. When CRC and DM are both enabled  $t_{WTR\_S\_CRC\_DM}$  is used in place of  $t_{WTR\_S}$ .
- 12. When CRC and DM are both enabled  $t_{WTR\_L\_CRC\_DM}$  is used in place of  $t_{WTR\_L}$ .
- 13. The max values are system dependent.
- 14. DQ to DQS total timing per group where the total includes the sum of deterministic and random timing terms for a specified BER. BER spec and measurement method are tbd.
- 15. The deterministic component of the total timing. Measurement method tbd.
- 16. DQ to DQ static offset relative to strobe per group. Measurement method tbd.
- 17. This parameter will be characterized and guaranteed by design.
- 18. When the device is operated with the input clock jitter, this parameter needs to be derated by the actual  $t_{jit}(per)_{total}$  of the input clock. (output Deratings are relative to the SDRAM input clock). Example tbd.
- 19. DRAM DBI mode is off.
- 20. DRAM DBI mode is enabled. Applicable to x8 and x16 DRAM only.
- 21.  $t_{QSL}$  describes the instantaneous differential output low pulse width on  $DQS\_t - DQS\_c$ , as measured from on falling edge to the next consecutive rising edge
- 22.  $t_{QSH}$  describes the instantaneous differential output high pulse width on  $DQS\_t - DQS\_c$ , as measured from on falling edge to the next consecutive rising edge
- 23. There is no maximum cycle time limit besides the need to satisfy the refresh interval  $t_{REFI}$
- 24.  $t_{CH}(abs)$  is the absolute instantaneous clock high pulse width, as measured from one rising edge to the following falling edge
- 25.  $t_{CL}(abs)$  is the absolute instantaneous clock low pulse width, as measured from one falling edge to the following rising edge
- 26. Total jitter includes the sum of deterministic and random jitter terms for a specified BER. BER target and measurement method are tbd.
- 27. The deterministic jitter component out of the total jitter. This parameter is characterized and guaranteed by design.
- 28. This parameter has to be even number of clocks
- 29. When CRC and DM are both enabled,  $t_{WR\_CRC\_DM}$  is used in place of  $t_{WR}$ .
- 30. When CRC and DM are both enabled  $t_{WTR\_S\_CRC\_DM}$  is used in place of  $t_{WTR\_S}$ .
- 31. When CRC and DM are both enabled  $t_{WTR\_L\_CRC\_DM}$  is used in place of  $t_{WTR\_L}$ .
- 32. After CKE is registered LOW, CKE signal level shall be maintained below  $V_{ILDC}$  for  $t_{CKE}$  specification ( Low pulse width).
- 33. After CKE is registered HIGH, CKE signal level shall be maintained above  $V_{IHDC}$  for  $t_{CKE}$  specification ( HIGH pulse width).  
 $UI=t_{CK}(avg).min/2$

Datasheet	11/28/2017
PS9MUxx64x8xxx	Viking Technology
Revision C	Page 41 of 41